

**Operating Manual**  
**OBSERVER® i**  
**Ultrasonic Gas Leak Detector**

Order No.: MANOBSERVER-I/L

Print Spec: 10000005389 (EO)

CR: 800000068836

**⚠ WARNING!**

These instructions must be provided to users before use of the product and retained for ready reference by the user. Read this manual carefully before using or maintaining the device. The device will perform as designed only if it is used and maintained in accordance with the manufacturer's instructions. Otherwise, it could fail to perform as designed, and persons who rely on this device could sustain serious injury or death.

---

The warranties made by MSA with respect to the product are voided if the product is not installed and used in accordance with the instructions in this manual. Please protect yourself and your employees by following the instructions.

Please read and observe the WARNINGS and CAUTIONS inside. For additional information relative to use or repair, call 1-800-MSA-2222 during regular working hours.

For countries of Russian Federation, Republic of Kazakhstan and Republic of Belarus, the gas detector will be delivered with a passport document that includes valid approval information. On the CD with manual instruction attached to the gas detector the user will find the documents "Type Description" and "Test Method" - appendixes to Pattern Approval Certificate of Measuring instrument, valid in the countries of use.

The Declaration of Conformity can be found under the following link: <https://MSAsafety.com/DoC>.

MSA is a registered trademark of MSA Technology, LLC in the US, Europe and other Countries. For all other trademarks visit <https://us.msasafety.com/Trademarks>.



**General Monitors**

by MSA

General Monitors  
16782 Von Karman Avenue, Unit 14  
Irvine, CA 92606  
1-949-581-4464

For your local MSA contacts, please go to our website [www.MSAsafety.com](http://www.MSAsafety.com)

# Contents

<b>1</b>	<b>Introduction</b>	<b>4</b>
<b>2</b>	<b>General Description and Features</b>	<b>4</b>
2.1	Artificial Neural Network (ANN)	4
2.2	Area Monitored by Observer i	5
2.3	Detector Outputs	5
<b>3</b>	<b>Installation</b>	<b>6</b>
3.1	Mechanical Construction	6
3.2	Mechanical Operation and Safety	7
3.3	Mounting	7
3.4	Wiring Diagram	8
3.5	Protective Earth Grounding	8
<b>4</b>	<b>Operation and Setup</b>	<b>9</b>
4.1	Receipt of Equipment	9
4.2	Normal Operation	9
4.3	Setup	9
4.4	Switching Modes	13
4.5	User Display and Magnet Interface	17
<b>5</b>	<b>Function Test, Gain Test and Calibration</b>	<b>37</b>
5.1	1701 Portable Test and Calibration Unit	37
5.2	Gain Test	37
5.3	Calibration	38
<b>6</b>	<b>Modbus Digital Interface</b>	<b>40</b>
6.1	Baud Rate	40
6.2	Data Format	40
6.3	Modbus Read Status Protocol (Query/Response)	40
6.4	Modbus Write Command Protocol (Query/Response)	41
6.5	Exception Responses and Exception Codes	41
6.6	Command Register Locations	42
6.7	Observer i Command Register Details	46
6.8	Event Logging (30H – 5FH)	55
<b>7</b>	<b>Customer Support</b>	<b>63</b>
<b>8</b>	<b>Additional Information</b>	<b>64</b>
8.1	Warranty	64
8.2	Specifications	65
8.3	Spare Parts and Accessories	67
8.4	Sound Source Calibration	69

### 1 Introduction



The Observer i is a third generation ultrasonic gas leak detector (UGLD) for the rapid detection of pressurized gas leaks. It utilizes the advanced acoustic and patented Artificial Neural Network (ANN) technology to only detect gas leaks while suppressing unwanted background noise, and incorporates the patented Senssonic™ self-test system for failsafe operation. Observer i also comes with standard industrial user and communication interfaces that provide flexible integration in a broad range of applications. This user manual describes the installation, operation, and maintenance of the Observer i to ensure its optimal performance.

**NOTE:** The "i" in the name Observer i stands for intelligent.

### 2 General Description and Features

The Observer i detects leaks from pressurized gas systems by sensing the airborne ultrasound produced by gas escaping from the leak. This detection method is omni-directional, functional in extreme weather conditions, and ideal for fast monitoring leaks from valves and flanges in complex pipeline systems, both onshore and offshore.

The main advantage using ultrasonic gas leak detectors is that the detector does not need to wait for gas accumulation, instead it responds instantly, in distances up to 28 meters, when a gas leak occurs. The Observer i is suitable in all pressurized gas installations, from 2 BAR (29 psi) or more, where the escaping gas is in a gaseous state when it leaks.

The Observer i can be configured to operate in Enhanced or Classic Modes. In Classic Mode, reminiscent of the legacy Observer-H UGLD, the alarm decision is based on the user-adjustable SPL threshold. The Classic Mode makes it possible to retrofit the Observer i into Observer and Observer-H installations. In Enhanced Mode, the detection method is based on the intelligent ANN algorithm that can distinguish gas leaks from background noise.

The Observer i is certified to ATEX, UKCA, IECEx, FM, CSA, HART, INMETRO and IEC 61508 standards. The detector housing is cast AISI 316L, acid-proof stainless steel and the ingress protection is IP66 with a NEMA rating of Type 4X. The performance of the Observer i as a safety device is not covered by the ATEX and UKCA certificates.

#### 2.1 Artificial Neural Network (ANN)

An essential performance parameter for an ultrasonic gas leak detector is to ensure high acoustic sensitivity to real gas leaks while minimizing the influence from background noise sources, unrelated to gas leaks. To ensure this important feature, the Observer i is the first ultrasonic gas leak detector to use multi-spectral Artificial Neural Network (ANN) algorithms in the detector's advanced acoustic sound processing design to distinguish real gas leaks from false alarms.

The ANN is a mathematical algorithm and is used to search for familiarity in a large and complex set of data. ANN works very similar to how the human brain handles the constant flow of information received through its senses - the eyes, ears, nose, and mouth. For example, when we have seen a face of a person in their youth and heard their voice, we are often able to recognize the person 20-30 years later, even if the person has changed over time. The reason we can recognize the person is that our brain is not programmed to search for an exact match or pattern, instead the brain looks for a combination of familiar similarities which the brain has been trained to compare and then make a decision. If the human brain did not look for familiarity when we met another person but instead looked only for an exact match as we remembered the person, we would only recognize that person if they had not changed and looked exactly the same.

An ultrasonic gas leak detector doesn't have to recognize people at different ages; instead it needs to effectively recognize the sound signature from gas leaks while also rejecting sound signatures from acoustic background noise unrelated to gas leaks. The Observer i uses advanced ANN algorithms to enhance and optimize the detector's ability to distinguish between normal background noise not related to leaking gas and real gas leaks. Due to the use of ANN technology, the Observer i is able to constantly record and analyze the flow of complex acoustic sound generated in very noisy plant environments, and instantly raise an alarm if the specific noise from a gas leak is recognized.

The Artificial Neural Network (ANN) makes it possible to analyze the incoming acoustic sound, based on the frequency domain instead of the sound level domain (dB levels) in individual frequency bands. As such, the Observer i detects only the sound from gas leaks, even if the gas leak sounds are occurring at much lower sound levels than the background noise. In reality this means that the ANN is extremely immune to false alarms from unwanted background noise sources, but at the same time extremely sensitive to gas leaks regardless of size.

The Observer i analyzes acoustic noise from as low as 12 kHz where other ultrasonic gas leak detectors have to filter out noise below 20 kHz to prevent interference from compressors or other man-made acoustic noise unrelated to gas leaks. With the ANN multi-spectral technology, the frequency band works down to 12 kHz, allowing more sound energy from potential gas leaks to be picked up and analyzed which provides a greater detection range of gas leaks.

With the ANN technology, the Observer i comes with pre-trained neural network algorithms from the factory and does not require complicated onsite training procedures to adapt to specific acoustic plant conditions; instead it is ready to operate in all kinds of acoustical environments, immediately after installation.

## 2.2 Area Monitored by Observer i

The Observer i is configured in either Enhanced or Classic Mode with SPL trigger levels as low as 44 dB and is capable of detecting 0.1 kg/sec gas leaks at on-axis distances of up to 30 meters. Illustrated in Figure 1, the detection area is based on actual gas leaks and represents the maximum coverage of the Observer i without a solid physical obstruction between the detector and the leak. With an increase in user-adjustable SPL trigger levels, the coverage area is equivalently decreased. In Enhanced Mode, the ANN algorithm eliminates the need for SPL trigger levels while at the same time filters out spurious alarms due to background nuisances, thereby increasing the leak detection coverage in high background noise areas.

Please consult your local representative for more information on area coverage or find more information in our UGLD Technical Handbook.

### Detector Coverage Characteristics (seen from side view)

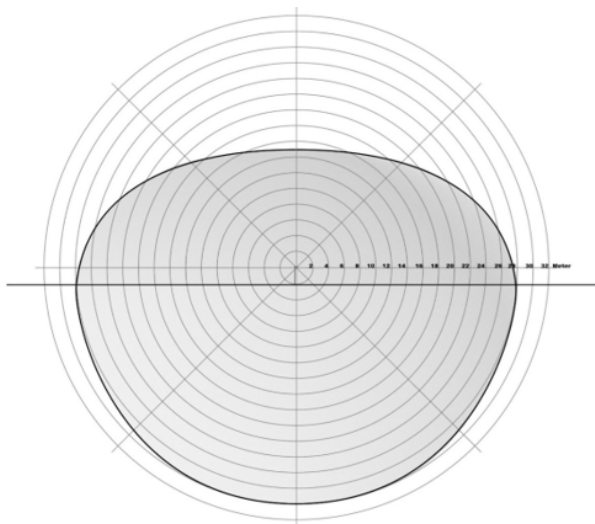

## 2.3 Detector Outputs

The Observer i UGLD has the following output capabilities:

- Analog Output 4-20 mA current loop interface – Sink or Source (factory setting = Source)
- Alarm relay to indicate potential gas leak alarm
- Error Relay to indicate detector fault
- HART 6.0 interface, operates over 4-20 mA current loop interface
- Modbus serial interface, operates on two separate wires, half-duplex RS-485

## 3 Installation

### 3.1 Mechanical Construction

The Observer i consists of two chambers. Both chambers are certified as flameproof (Ex d) and Explosion-proof (XP). The cables are connected through M20 x 1.5 6H cable entries in the top chamber using approved Ex d glands or approved conduit with seals installed within 18" of the detector. The inner cores of the cable penetrating the detector should be at least 25 cm long. This will ensure no tension on the wires and connector PCB when the top chamber is opened. The two mounting bolts are on the top chamber of the detector so that the cables will enter on the fixed part of the detector. The bottom part is attached to the top by means of six Allen screws with lock washers. Unscrewing these screws will expose the connector PCB in the top chamber. These screws will be fixed by retaining washers to the bottom chamber. The bottom chamber of the detector is supported by the load-strap, which is connected to the top chamber.

The bottom chamber contains integral associated intrinsically safe apparatus limiting energy to an intrinsically safe microphone and piezo source, mounted to the exterior of the enclosure.

#### Internal Construction

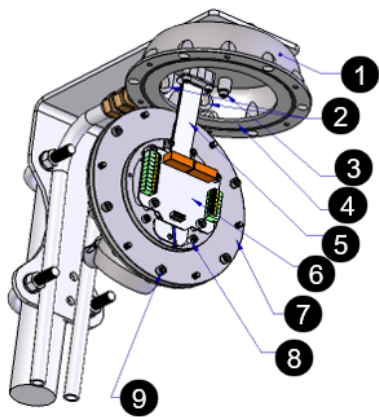

- 1 Top Housing (the fixed part of the detector)
- 2 M20X1.5 Cable Entry 6H
- 3 M5 Earth Connection
- 4 Flame Path
- 5 Load Strap
- 6 Relay Board
- 7 Bulkhead separate the 2 chambers and permanently attached to the bottom chamber
- 8 IS Ground
- 9 M6 Allen screw and lock washer (6X) must be tightened with 9 Nm torque

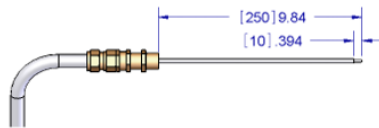

Wire Lengths Inside the Top Chamber

#### External Construction

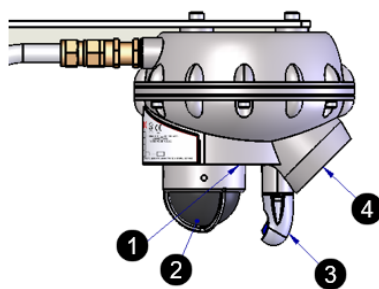

- 1 Optical Link Window
- 2 Microphone
- 3 Test Sound Source
- 4 User Interface (switches operated magnet-stick)

### 3.2 Mechanical Operation and Safety

When closing the top chamber ensure that the load strap and wires are not caught between the bulkhead and the top part of the detector. Check the status of the O-ring and the flame path. Replace the O-ring if damaged. Consult the factory for repair if the flame path is damaged.

**NOTE:** The ambient temperature is limited to  $-40^{\circ}\text{C}$  to  $+60^{\circ}\text{C}$ . The performance of the Observer i Ultrasonic Gas Leak Detector, as a safety device per clause 1.5 of Annex II of the ATEX Directive 2014/34/EU and per UKSI 2016:1107 (as amended) for the UK is not covered by the ATEX and UKCA certificates.

**NOTE:** This equipment is comprised of an Explosionproof housing providing intrinsically safe outputs to an externally mounted intrinsically safe microphone and piezo source. When used in Division 2 locations, a seal is not required at the housing.

The Observer-I Ultrasonic Gas Leak Detector is electrically rated for use with extra-low voltage and must be powered by Class 2/SELV power supply, capable of offering overvoltage protection, overcurrent protection, and transient voltage protection from Hazardous voltages.

#### 3.2.1 Specific Conditions of Use

- The Class A2-70 M6x1x20 screws connecting the bulkhead flange joints must be tightened to 9 Nm using a torque wrench.
- Consult the manufacturer if dimensional information on the flameproof joints is necessary.
- Do not open when an explosive atmosphere is present. Read and understand this instruction manual before operating or servicing.

#### **⚠ WARNING!**

- The inner six screws should not be unscrewed and the bottom chamber should not be opened. The warranty will be void if the bottom chamber is opened.
- Danger of electro-static sparking. Clean non-metallic parts only with a damp cloth.

(missing or bad snippet)

### 3.3 Mounting

Two M8 stainless steel bolts (not supplied), 88 mm apart, attached to the top of the detector are used to fix the Observer i in its operating position. These bolts may penetrate the detector top by a maximum of 14 mm. The detector can be mounted to a freestanding pole or wall, using mounting bracket 80601-1. This bracket is an optional accessory and is supplied with two M8 mounting U-bolts which can fit around a pole with a maximum dimension of 63 mm. It is possible to mount the detector directly onto non-vibrating structural beams or cable-trays. The microphone should face downwards and if tilting of the detector is necessary, the angle of incline should not exceed  $45^{\circ}$ . When mounting the detector within half a meter of a solid structure, such as a wall or a big vessel, the acoustic test sound source shall be pointed away from the structure. The sound source should be pointing into free space as far as possible.

Mounting Diagram

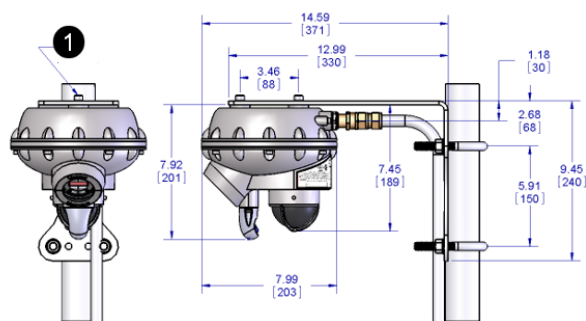

1 Mounting screw M8 x 19 max (2X)

### 3 Installation

#### 3.4 Wiring Diagram

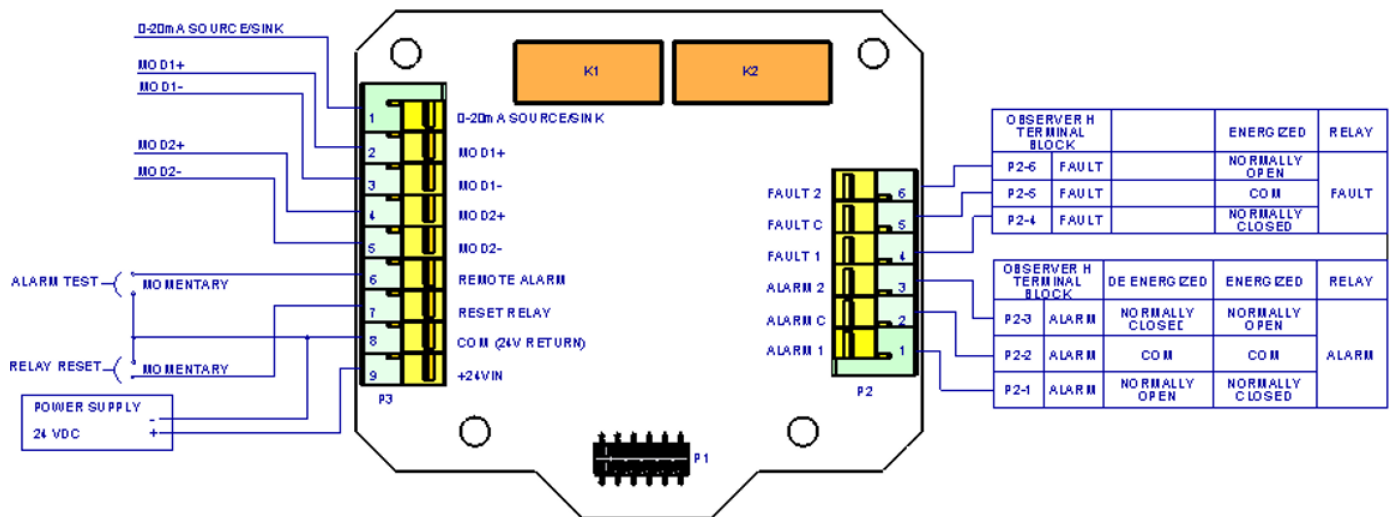

#### 3.5 Protective Earth Grounding

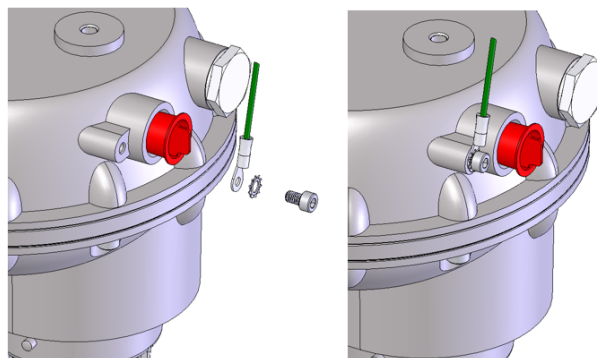

*External Earth Terminal*

The protective earth ground terminal requires the use of an M5 ring lug and star washer. The wire gauge should be less than or equal to the gauge of the power supply wires.

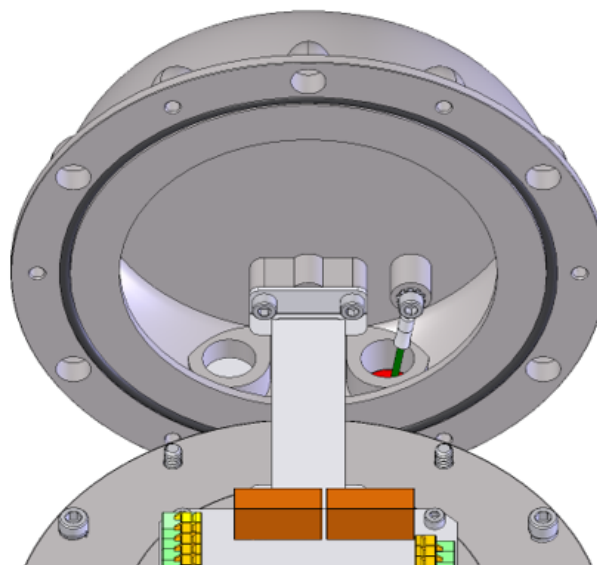

*Internal Earth Terminal*

## 4 Operation and Setup

### 4.1 Receipt of Equipment

All equipment shipped is packaged in shock absorbing containers, which provide considerable protection against physical damage. The contents should be carefully removed and checked against the packing list. If any damage has occurred or there is any discrepancy in the order, please notify the manufacturer as soon as possible. All subsequent correspondence with the manufacturer must specify the equipment part number and the serial number.

### 4.2 Normal Operation

**Power up:** The Observer i unit initializes its microprocessor, conducts internal tests and goes into the normal operation mode within a few seconds. During the power up, the analog output current is set at 0.0 mA; the software revision and "TEST" are displayed in sequence.

**Normal:** The real-time SPL is shown on the display. The corresponding 4-20 mA analog output value is set depending on the detection mode, Classic or Enhanced.

**Alarm:** Depending on the detection mode (Classic Mode or Enhanced Mode), display shows "A" or "C" in front of the SPL reading. The alarm relay\* is turned on.

**Error:** Display shows the type of error, and the error relay is turned on. By default, the error relay is energized.

**Self-Test:** The acoustic self-test is done at regular intervals, and during the test, the display shows a fixed SPL reading recorded immediately prior to its start.

**NOTE:** Both alarm and error relays are configured as single poll, double throw.

### 4.3 Setup

The setup can be done in three different ways. The display/magnet is a user input that only requires a magnet as an external tool. It is best used in simple systems. HART is a method that requires a HART modem and supporting software. It is best used where there is existing wiring and control information is desired. Modbus requires a separate pair of wires and an RS-485 to PLC converter. It is best used for large systems.

#### 4.3.1 Detection Modes

The Observer i supports two detection modes:

**Classic Mode:** Gas leak detection is based only on the SPL Alarm trigger

**Enhanced Mode:** Gas leak detection is based on ANN algorithm and ANN Sensitivity Level

See [4.4 Switching Modes](#) for selecting detection modes.

#### 4.3.2 SPL Alarm Trigger

In Classic Mode, the SPL alarm trigger shall be set at least 6 dB higher than the background noise. When using the Alarm Relay, the trigger level setting should be set internally by means of an adjustable trigger level in 5 dB steps between 44 and 99 dB. When using the Analog Output, the trigger level should be set in the fire & gas system. The factory default setting is 79 dB.

### 4.3.3 ANN Sensitivity Level

In Enhanced Mode, the internal dB setting is referred to as the ANN Sensitivity Level. The ANN sensitivity level is the SPL level (dB) at which the ANN starts to operate. For example, if the ANN is set to 64 dB, all acoustic noise received by the Observer i with a sound level below 64 dB will NOT be passed as a positive by the ANN. When the SPL exceeds 64 dB, the ANN will pass a gas leak as a positive and trigger an alarm. It is recommended to keep the ANN sensitivity as low as possible to enhance the detection range and use the full potential of the ANN technology. The ANN sensitivity is set internally by means of the magnet on the display in 5 dB steps between 44 and 99 dB. The factory default setting is 59 dB for Enhanced Mode FQHI. It is recommended that Enhanced Mode is used with an ANN Sensitivity Level greater than or equal to 59 dB for FQHI and greater than or equal to 54 dB for FQLO.

### Delay Time

An internal alarm delay time is implemented to eliminate spurious alarms due to short background noise peaks. This delay time can be set internally from 0 to 240 seconds. The factory default setting is set to 10 seconds for Classic Mode and 2 seconds for Enhanced Mode.

In Classic Mode, the internal alarm delay time is only connected to the alarm relay and not the 4-20 mA analog output. When using the analog output in Classic Mode, an alarm delay should be programmed in the fire & gas system.

In Enhanced Mode, the delay time controls the alarm relay as well as the analog output. The delay time in Enhanced Mode represents the time a gas leak is recognized by the ANN; an alarm is raised on the analog output and the alarm relay becomes active.

### 4.3.4 Alarm Relay Energized / De-Energized

The alarm relay can be normally energized or normally de-energized. In either energized state the single poll double throw allows for the opening or closing of a contact for an alarm. The normally energized state is a failsafe method. If an alarm or power outage occurs, an alarm condition will be indicated. The factory default setting is normally de-energized.

### 4.3.5 Alarm Relay Latch / Non-Latched

The alarm relay can be latched to retain the alarm condition even if the gas leak goes away. This relay feature can be configured using a magnet on the display as well as via HART or Modbus interfaces. The factory default setting is non-latched.

### 4.3.6 Modbus

Modbus is an optional serial communication channel used to obtain control information. The Observer i has two independent Modbus channels. The second Modbus channel can be configured as an optional HART interface.

Baud rates: 2400, 4800, 9600, 19200, 38400, 57600 bps  
Factory default is 19200 bps

Formats 8-N-1, 8-N-2, 8-O-1,  
Factory default is 8-N-1

Address  
Factory default is Channel 1 Address 1 and Channel 2 Address 1

### 4.3.7 HART Enable

Selects whether channel 2 is Modbus or HART  
Factory default is if HART is installed HART is enabled & current is normal

### 4.3.8 HazardWatch

HazardWatch is used when the Observer i is part of a General Monitors HazardWatch Fire and Gas System or a MSA Model 10K system. The factory default is disabled.

### 4.3.9 Acoustic Self-Test

An acoustic self-test (named Senssonic™) is done every 15 minutes and takes approximately 8 seconds. A test signal with a frequency sweep at constant amplitude is transmitted by the ultrasonic sound source to the microphone. The detector analyzes the result of the sweep and stores the highest SPL value in dB. This value is compared to a factory reference value and the result must be within a predefined tolerance. If the test signal is out of the predefined tolerance, the Observer i will repeat the acoustic self-test 30 seconds after the first failed test. If this test signal is still out of tolerance another acoustic self-test is done again 30 seconds later. If the third test signal is still out of tolerance, the Observer i will indicate an acoustic error mode. In this mode the “ERAC” code is displayed, and the Error Relay is turned on. The user can acquire the relay status via the Modbus or HART digital communication interfaces. Furthermore, the 4-20 mA output indicates 1 mA for 5 seconds and returns to indicating a corresponding SPL reading until the next acoustic test failure. This sequence will repeat until the acoustic fault is repaired.

The self-test error can be caused by:

- An obstacle blocking the sound path
- A faulty self-test sound source
- A faulty microphone

If none of the above is true, the Observer i unit can be tested via a “Gain Test” with the 1701 Portable Test and Calibration Unit, before sending the Observer i back to the factory for service.

During the acoustic self-test, the Observer i displays the last SPL reading recorded immediately before the start of the test and indicates the corresponding fixed current level on the 4-20 mA analog output. A green LED is also illuminated during the self-test and can be seen through the optical link window.

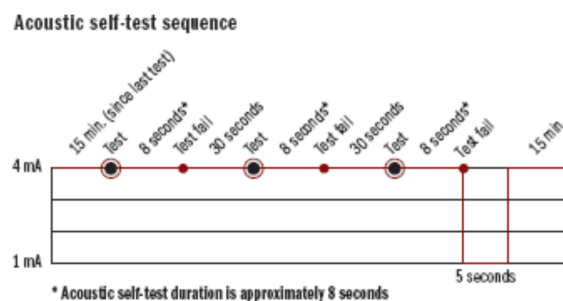

### 4.3.10 Inputs

**Remote Alarm Reset:** The Observer i has a remote relay reset switch that enables the user to reset relays remotely, without physically accessing the Observer i unit.

**Restore Defaults:** The remote reset pin is also used to restore some user options (Modbus parameters, SPL alarm trigger, delay time, etc.) back to the default values. This is done by grounding the pin and turning the power on. The pin must remain grounded for one minute after the power is turned on.

**Alarm Test:** The Observer i has provisions for a remote alarm test. This is useful to test out the external system wiring. Grounding the alarm test pin will put the Observer i in alarm mode, in which it will remain until the alarm test pin is removed. If the grounding time is longer than 30 seconds, the device will go into fault.

### 4.3.11 Output Methods

The Observer i has 4 major output methods:

Alarm Relay Output – Can be configured as normally energized/de-energized

Errors Relay Output – Always configured as normally energized

4-20 mA Analog Output – Can be configured as source or sink

Serial Digital Communication – Configurable as Dual Modbus or Single Modbus and HART (optional)

The user needs to determine the appropriate output method.

### 4.3.12 Relay Ratings

8 A @ 250 VAC

See graph in [8.2.1 Electrical Specifications](#) DC ratings

### 4.3.13 Alarm Relay Output

In Classic Mode, the SPL alarm trigger shall be set at least 6 dB higher than the background noise. When using the Alarm Relay the trigger level setting should be set internally by means of an adjustable trigger level in 5 dB steps between 49 and 99 dB. When using the Analog Output, the trigger level should be set in the fire & gas system. The factory default setting is 79 dB.

In Enhanced Mode, the internal dB setting is referred to as the ANN Sensitivity Level. This is set internally by means of the magnet on the display in 5 dB steps between 49 and 99 dB. The ANN Sensitivity Level is a dB level which keeps the detector from going into alarm on a positive ANN event, unless the SPL has past the preset ANN Sensitivity Level.

An alarm delay time is implemented to eliminate spurious alarms due to short background noise peaks. This delay time is particularly important in Classic Mode when ANN is not used for gas detection. The delay time can be set between 0 and 240 seconds. The factory default setting for delay is 2 seconds in Enhanced Mode and 10 seconds in Classic Mode. The delay can alternatively be configured via the “Fire and Gas Panel”, Modbus or HART.

When a gas leak occurs in the detector’s coverage area and the detector is in Classic Mode, the trigger level will be reached, the LED in the optical link window will be illuminated, and the alarm relay timer will be started. When the delay times out, the unit will go into alarm mode.

When a gas leak occurs in the detector’s coverage area and the detector is in Enhanced Mode, the ANN will calculate the probability of a true gas leak and will result in a positive. When the ANN Sensitivity Level is also reached, the LED in the optical link window will be illuminated and the alarm relay timer will be started. When the delay times out, the unit will go into alarm mode.

An alarm mode results in the following:

- The dB value preceded by an “A” (“C” in Classic mode) will flash on the display
- The alarm relay will activate
- The analog output will change according to the output mode (see [4.4 Switching Modes](#))
- An event will be recorded

### 4.3.14 4-20 mA Output

In normal operation, the output is between 4 and 20 mA. When using this output method in Classic Mode, the SPL trigger is set at least 6 dB higher than the background noise, and the alarm delay time of  $\geq 10$  seconds should be set in the fire & gas system. For Enhanced Mode, an internal alarm delay time  $\geq 2$  seconds and an ANN Sensitivity Level between 54 and 84 dB is recommended. For maximum coverage distance, the ANN Sensitivity Level can be set at 44 dB. The ANN Sensitivity Level is indicated by “TL” in the menu structure [see [4.5.3 Setting / Checking Trigger Level \(ANN Sensitivity Level\)](#)].

#### Classic Mode

The 4-20 mA represents 40 dB to 120 dB.

The output value in mA corresponding to the SPL in dB can be calculated by the following formula:

$$\{[(n - 40) * 16] / 80\} + 4 = x$$

n: Sound Level in dB  
x: Output value in mA

#### Enhanced Mode

In Enhanced Mode, the unit utilizes ANN. This means that the unit is constantly calculating the probability of the input being a real gas leak. In Enhanced Mode, the user has three Analog Outputs to choose from. These outputs are:

**Discrete SPL (EAO1 shown in display):** 4 – 12 mA represents 40-120 dB. 16 mA for Warning and 20 mA for Alarm (Warning is before the delay time runs out)

$$\{[(n - 40) * 8] / 80\} + 4 = x$$

n: Sound Level in dB  
x: Output value in mA

**Discrete (EAO2):** 4 mA for Normal, 16 mA for Warning and 20 mA for Alarm

**SPL Only (EAO3):** 4-20 mA represents 40-120 dB. This output mode is generally only used with the GM HazardWatch or MSA Model 10k Fire and Gas Systems. The user can use the SPL trigger to set the threshold for alarm, similar to Classic Mode. The SPL trigger should be at least 6 dB higher than the background noise. The Alarm relay is controlled by an adjustable trigger level in 5 dB steps, from 44 to 99.

#### 4.3.15 Error / Fault Output

Error/fault conditions are indicated in many ways:

- On the User Interface display
- Through the 4-20 mA analog output
- The Error/Fault relay will de-energize
- The HART digital information will show an error
- The Modbus digital information will show an error
- A fault event will be recorded every 30 seconds

#### 4.4 Switching Modes

Table 1 Analog Output Level

Classic Mode, (Display=CLSM)			
Function	HART Disabled	HART Enabled (Standard)	HART Enabled (Special)
Normal Analog Output	4 mA to 20 mA = 40 dB(u) to 120 dB(u)	4 mA to 20 mA = 40 dB(u) to 120 dB(u)	4 mA to 20 mA = 40 dB(u) to 120 dB(u)
Menu Activated	3 mA	3.5 mA	3 mA
Acoustic Error	1 mA	3.5 mA	1.25 mA
Low Supply Voltage	0 mA	3.5 mA	1.5 mA
Enhanced Mode, Discrete SPL mode (Display=EAO1)			
Function	HART Disabled	HART Enabled (Standard)	HART Enabled (Special)
Normal Analog Output	4 mA to 12 mA = 40 dB(u) to 120 dB(u)	4 mA to 12 mA = 40 dB(u) to 120 dB(u)	4 mA to 12 mA = 40 dB(u) to 120 dB(u)
Analog Output, Warning/Alarm	16/20 mA	16/20 mA	16/20 mA
Menu Activated	3 mA	3.5 mA	3 mA
Acoustic Error	1 mA	3.5 mA	1.25 mA
Low Supply Voltage	0 mA	3.5 mA	1.5 mA
Enhanced Mode, Discrete mode (Display=EAO2)			
Function	HART Disabled	HART Enabled (Standard)	HART Enabled (Special)
Normal Analog Output	4 mA	4 mA	4 mA
Analog Output, Warning/Alarm	16/20 mA	16/20 mA	16/20 mA
Menu Activated	3 mA	3.5 mA	3 mA
Acoustic Error	1 mA	3.5 mA	1.25 mA
Low Supply Voltage	0 mA	3.5 mA	1.5 mA
Enhanced Mode, Full SPL mode (Display=EAO3)			
Function	HART Disabled	HART Enabled (Standard)	HART Enabled (Special)
Normal Analog Output	4 mA to 20 mA = 40 dB(u) to 120 dB(u)	4 mA to 20 mA = 40 dB(u) to 120 dB(u)	4 mA to 20 mA = 40 dB(u) to 120 dB(u)
Analog Output, Warning/Alarm	4 mA to 20 mA = 40 dB(u) to 120 dB(u)	4 mA to 20 mA = 40 dB(u) to 120 dB(u)	4 mA to 20 mA = 40 dB(u) to 120 dB(u)
Menu Activated	3 mA	3.5 mA	3 mA
Acoustic Error	1 mA	3.5 mA	1.25 mA
Low Supply Voltage	0 mA	3.5 mA	1.5 mA

## 4 Operation and Setup

When HART is selected, the output current changes to comply with the HART Foundation requirements. The HART Foundation does not specify current below 3.5 mA. In normal HART mode, the actual current does not go below 3.5 mA. Modbus reports the analog output as if HART was not there. This allows users to use a constant Modbus program. When the alarm relay is latched, the current and display follows the present dB. The relay returns to normal after the relay reset is activated via Modbus, HART, or remote switch.

The unit will have an Inhibit output when Setup, Calibrate, or Acoustic Test is activated. This activation takes place via display magnets, HART, or Modbus.

Source – The detector sends out a current loop.

Sink – The detector receives a current loop.

### 4 – 20 Output Examples

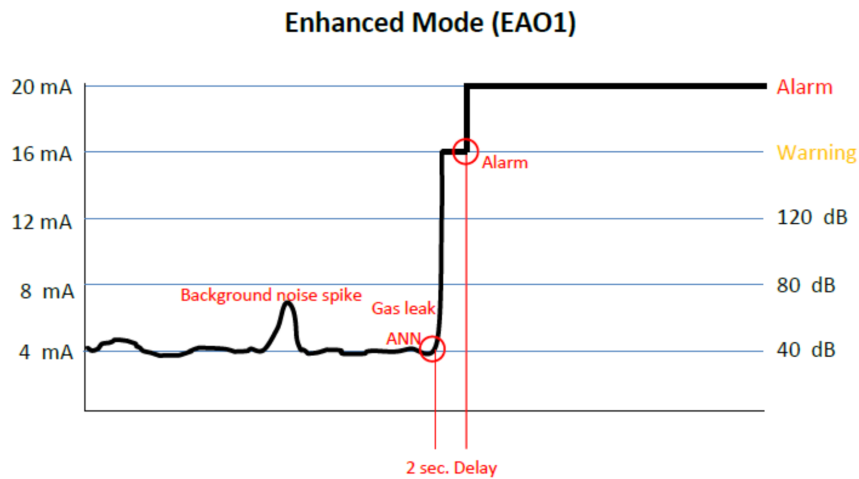
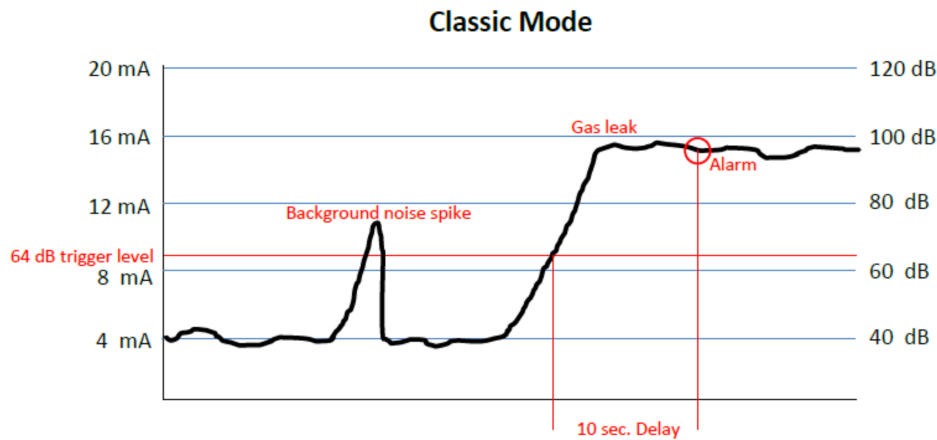

### Enhanced Mode (EAO2)

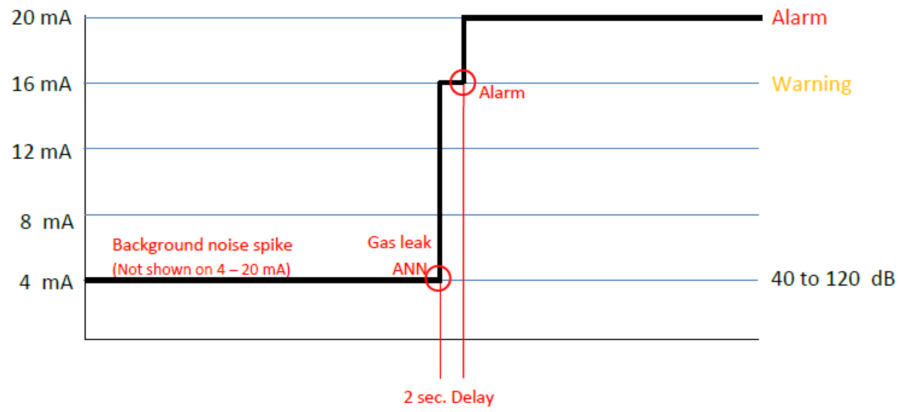

### Enhanced Mode (EAO3)

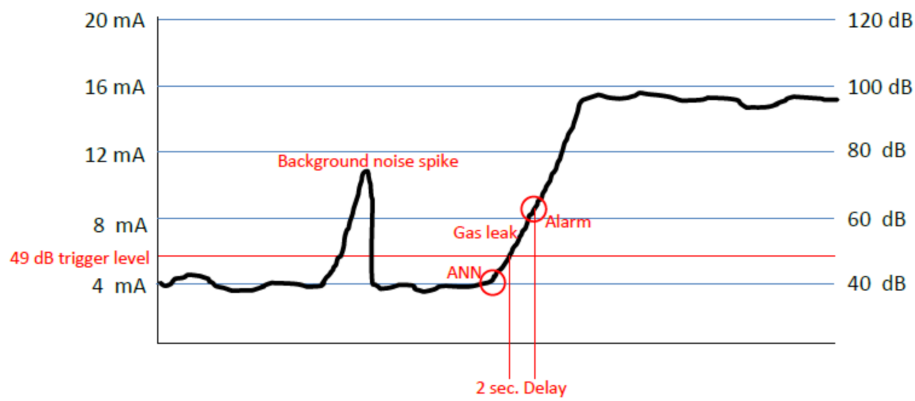

## 4 Operation and Setup

Table 2 Error / Fault Indications

Error / Fault	Display	AO	Modbus	Error Relay	User Action	Gas Overrides
Low supply	ERV-	0 mA*	0 mA	De-energized	Restore proper operating voltage	Yes
Acoustic Error	ERAC	1 mA**	0 mA	De-energized	Check sound path from piezo to microphone	Yes
Remote alarm switch stuck	EAST	0 mA*	0 mA	De-energized	Check switch wiring	Yes
Remote relay reset switch stuck	ERST	0 mA*	0 mA	De-energized	Check switch wiring	Yes
Magnetic sensors stuck	EMAG	0 mA*	0 mA	De-energized	Remove magnet	Yes
Internal voltage error	EINV	0 mA*	0 mA	De-energized	Return to factory	No
Critical memory error	ECRT	0 mA*	0 mA	De-energized	Return to factory	No
User memory error	EUSR	0 mA*	0 mA	De-energized	Recycle power and restore user defaults.	No
HART memory error	EHRT	0 mA*	0 mA	De-energized	Recycle power and restore HART information.	No
Event memory error	EEVT	0 mA*	0 mA	De-energized	Recycle power event data maybe accurate.	No

\* See acoustic self-test sequence in [4.3.9 Acoustic Self-Test](#). \*\* See HART output current in [4.4 Switching Modes](#).

### Low Supply

This fault occurs if the supply voltage at the Observer i drops below +12.5 VDC. When the supply returns to normal, the Observer i will go back to start up.

**Action** - Ensure that the supply voltage is at least +14 VDC at the Observer i.

### Acoustic Error

The Observer i has failed the acoustic test.

**Action** - Make sure the foam and all acoustic parts are clean. Replace the Sound Source.

### Remote Alarm Switch Stuck

The “remote alarm” is closed for 60 seconds.

**Action** - Check the wiring on the remote alarm. Once the short circuit is cleared, the unit will return to normal operation.

### Remote Relay Reset Switch Stuck

The “remote reset” is closed for 30 seconds.

**Action** - Check the wiring on the remote reset switch. Once the short circuit is cleared, the unit will return to normal operation.

### Magnetic Sensors Stuck

The “magnetic sensor stuck” is closed for 60 seconds.

One of the four magnet switches or a cable is shorted.

**Action** - If the magnetic switch is shorted, the unit must be returned to the factory or authorized service center for service.

### Internal Voltage Error

The possible errors are an internal voltage is not at the proper value or a circuit is not functioning properly.

**Action** - An internal error has occurred. The unit must be returned to the factory for service.

### Critical Memory Error

This is a main memory error and the Observer i may not function correctly.

**Action** – The unit must be returned to the factory or authorized service center for repair.

### **User Memory Error**

User memory includes the trigger level, delay time, latched/non-latched, energized/non-energized, Modbus setting, or any other user changeable settings. This error indicates one or more of these values are wrong.

**Action** – Cycle power. The error will go away, but the data is still not correct. The user must restore all user settings.

### **HART Memory Error**

A HART memory register has an error. These registers contain HART user settings. This error indicates one or more of these values are incorrect.

**Action** – Cycle power. The error will go away but the data is still not correct. The user must restore all HART information.

### **Event Memory Error**

Event memory has an error. Some or all of the event information is incorrect. This error indicates one or more of these values are wrong.

**Action** – Cycle power. The error will go away, but the data is still not correct.

The Observer i has four different memory blocks that are periodically checked. The user is notified via the Error / Fault Output function if an error occurs with any of these memory locations.

When HART is selected, the output current changes to comply with the HART Foundation requirements. The HART Foundation does not specify current below 3.5 mA. In normal HART mode, the actual current does not go below 3.5 mA. Modbus reports the analog output as if HART was not there. This allows users to use a consistent Modbus program. When the alarm relay is latched, the current and display follows the present dB. The relay will return to normal after the relay reset is activated via Modbus, HART, or remote switch.

The unit will have an Inhibit output when Setup, Calibrate, or Acoustic Test Mode is activated. This activation can take place via display magnets, HART, or Modbus.

## **4.5 User Display and Magnet Interface**

The User Interface consists of a four-digit LED display window and four magnetic switches to enable a local operator to confirm or change settings without opening the unit. When the user interface is used the Observer i will change to setup mode. The setup mode consists of the following tests: Analog Output=3.5 mA (HART Enable), 3.0 mA (HART Disable).

User Menu Diagram

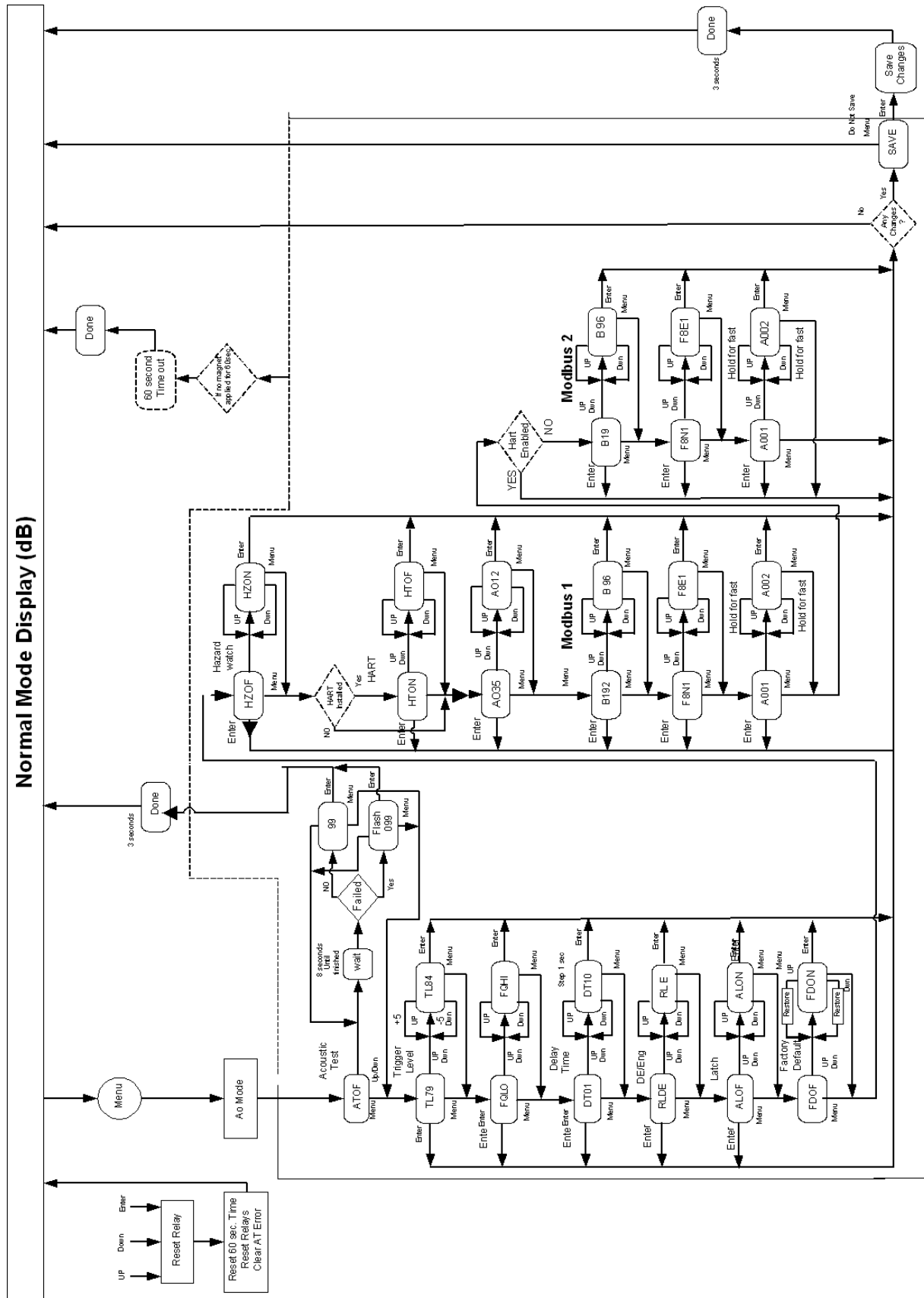

#### 4.5.1 Setting / Checking Detection Mode and Analog Output Mode

The Detection Mode can be set by placing the magnet at the MENU button during start up for 5 seconds. At the end of the start-up, the Observer i will go to the detection set up menu by displaying “ENON” for Enhanced Mode On or “ENOF” for Enhanced Mode off. “ENOF” means the Observer i is in Classic Mode.

The Classic Mode has only one analog output mode: 4-20 mA represents 40-120 dB. The Observer i automatically switches to this current mode when the Classic Mode is selected.

The Observer i will default to Discrete SPL (EAO1) when Enhanced Mode is selected. If the user wants to change the Enhanced Analog output mode, after “ENON” is selected, press the MENU button and the display will show “EAO1”. Use the UP and DOWN button to select the available current modes.

To check the Detection Mode or Analog Output Mode, press the MENU button when the Observer i is in standby, the Observer i will flash the options below for 2 seconds:

“CLSM”: Observer i is in Classic Mode.

“EAO1”: Observer i is in Enhanced Mode and Analog output is in Discrete SPL mode.

“EAO2”: Observer i is in Enhanced Mode and Analog output is in Discrete mode.

“EAO3”: Observer i is in Enhanced Mode and Analog output is in Full SPL mode.

#### 4.5.2 Forced Acoustic Test

This will enable the local operator to test the acoustic properties of the unit. Activate the MENU switch with the magnet-stick. The code “ATOF” (Acoustic Test Off) will be displayed. Activating the UP switch (▲) will display the “wait” command followed by the sound level detected by the microphone emitted from the sound source. If this value is flashing, the unit is failing the acoustic test. There could be a number of causes for this error, see [4.4 Switching Modes](#) for more information. The DOWN switch (▼) will stop the acoustic test and display “ATOF”. Activating the ENTER switch at any time during this operation will display “DONE” and take the unit back to Normal Operation. A maintenance event will be recorded. If no switch is activated for 60 seconds the detector will return to normal operation.

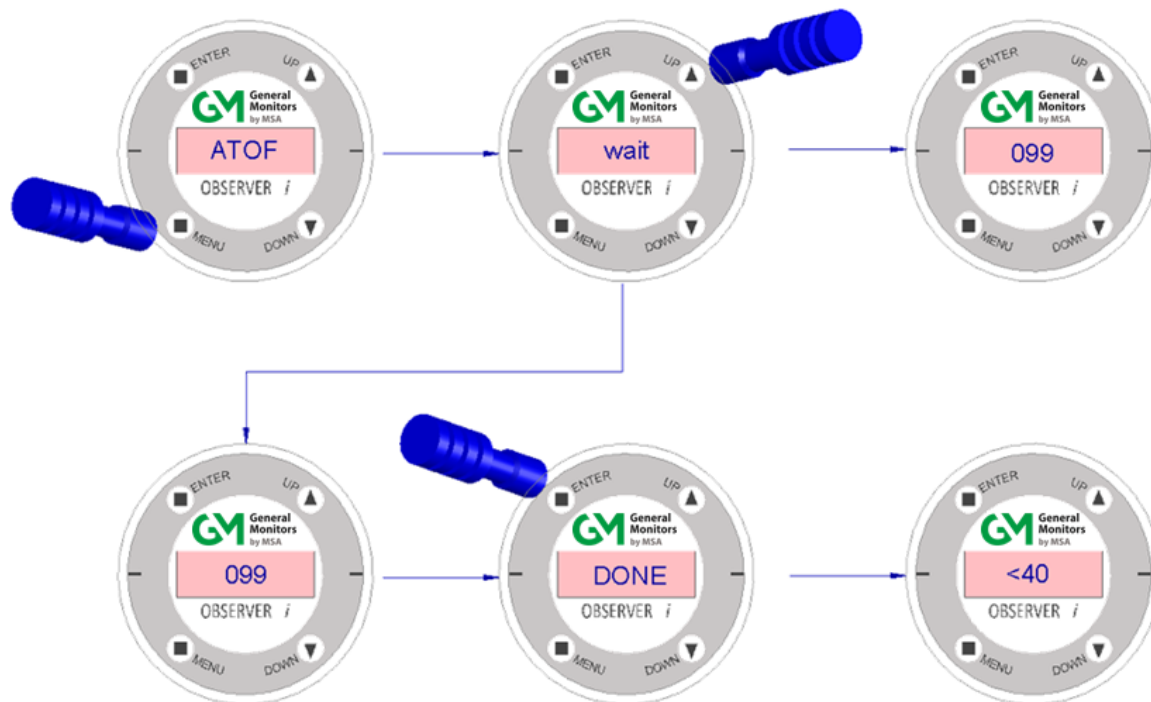

### 4.5.3 Setting / Checking Trigger Level (ANN Sensitivity Level)

Depending on Classic Mode or Enhanced Mode, the trigger level or ANN Sensitivity Level can be set from 44 to 99 dB in steps of 5 dB. In Classic Mode, the ALARM RELAY will activate at this trigger level, changing from open contact to closed (factory default) and in Enhanced Mode the ANN Sensitivity Level will control the SPL dB level which needs to be reached, together with a positive ANN calculation to trigger a unit alarm.

Activate the MENU switch twice with the magnet-stick. The current trigger level will be displayed (factory setting is 79 dB for Classic Mode and 59 dB for the ANN Sensitivity Level for Enhanced Mode FQHI). Activating the UP switch (▲) will increment the trigger level by 5 dB. Activating the DOWN switch (▼) will decrease the Trigger Level in 5 dB increments. Activating the ENTER switch without changes made, switches the unit back to Normal Operation. Activating the ENTER switch with changes made, will flash "SAVE" on the display. Confirm the save action by activating the ENTER switch once more. Activating the MENU switch while "SAVE" is flashing, will discard the save and switch the unit back to Normal Operation. If ENTER was activated the unit will display "DONE" to confirm that the changes have been saved and return to Normal Operation.

The operator can change the trigger level and, if desired, move to the next item (Cut-off Frequency) in the menu structure by activating the MENU switch straight after the change. The change will be saved at a later stage by activating the ENTER switch at any point in the menu structure. If no switch is activated for 60 seconds, the detector will return to normal operation without saving the changed settings.

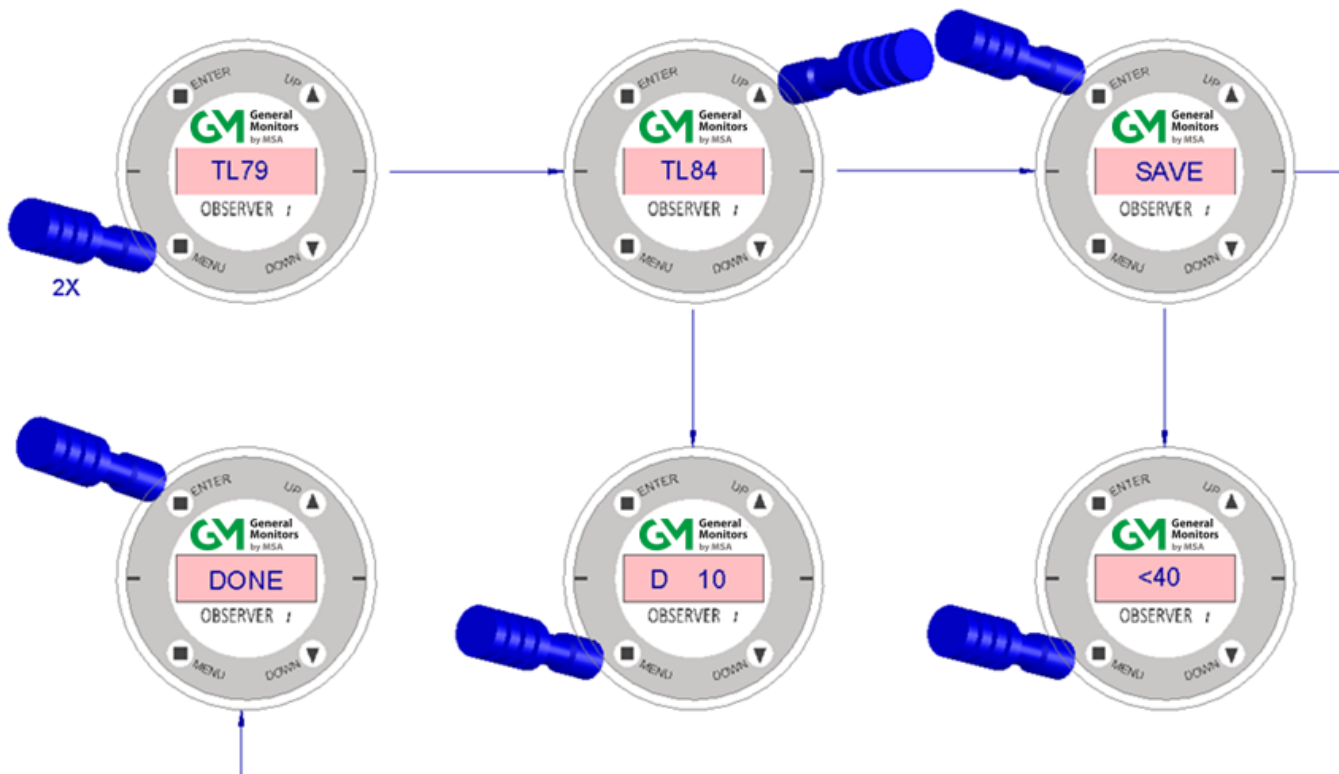

#### 4.5.4 Setting / Checking Cut-Off Frequency (Enhanced Mode only)

In Enhanced Mode the cut-off frequency of the unit can be set between high (FQHI) and low (FQLO). The factory default setting is “FQHI” to eliminate spurious alarms in ultra-high noise areas. This setting can be set to “FQLO” in medium and low noise areas, which will still allow ANN to protect against spurious alarms and have a slight increase in coverage.

Activate the MENU switch three times with the magnet-stick. The current cut-off frequency will be displayed (factory setting FQHI). Activating the UP switch (▲) or DOWN switch (▼) will toggle between “FQHI” and “FQLO”. Activating the ENTER switch without changes made, switches the unit back to Normal Operation. Activating the ENTER switch with changes made, will flash “SAVE” on the display. Confirm the save action by activating the ENTER switch once more. Activating the MENU switch while “SAVE” is flashing, will discard the save and switch the unit back to Normal Operation. If ENTER was activated the unit will display “DONE” to confirm that the changes have been saved and return to Normal Operation.

The operator can change the cut-off frequency and if desired move to the next item (delay time) in the menu structure by activating the MENU switch straight after the change. The change will be saved at a later stage by activating the ENTER switch at any point in the menu structure. If no switch is activated for 60 seconds the detector will return to normal operation without saving the changed settings.

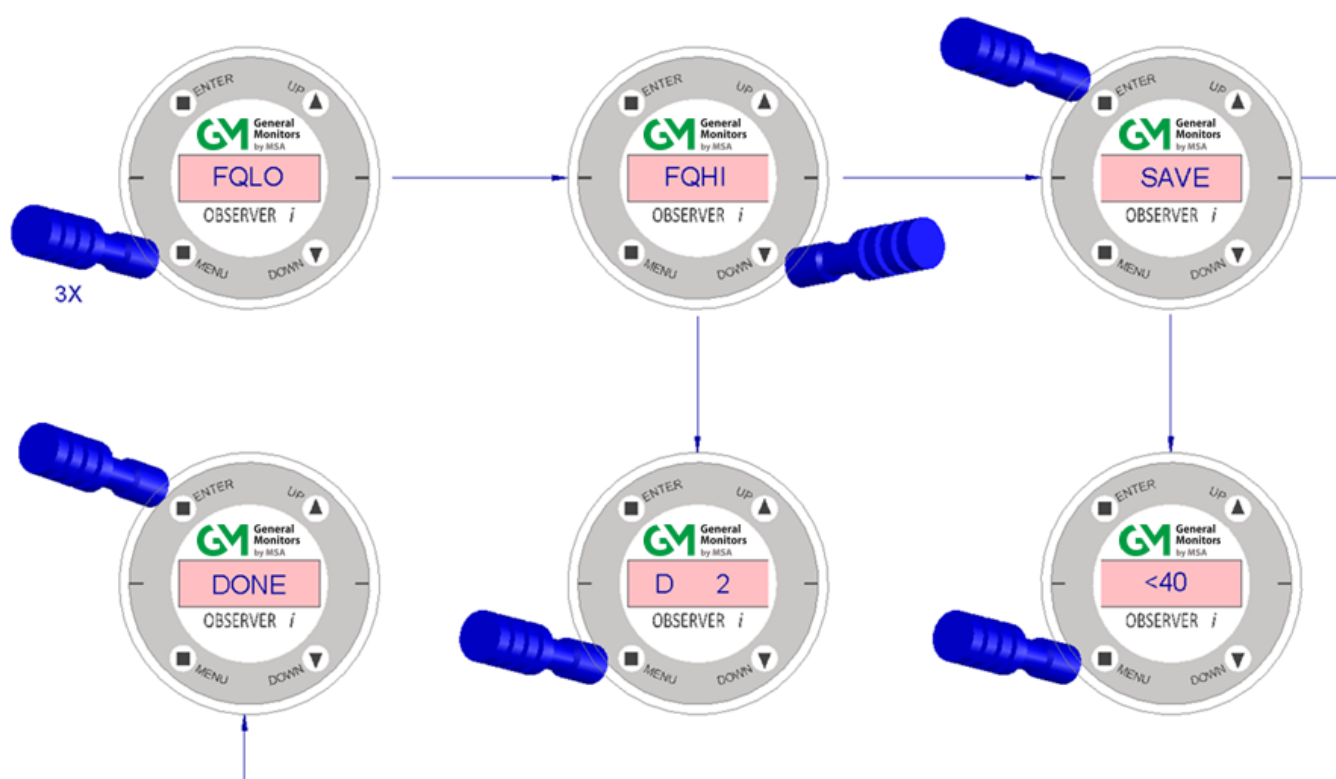

4.5.5 Setting / Checking Delay Time

The delay time is linked to the ALARM RELAY. The delay time can be set from 0 to 240 seconds. If the relay output is being used for executive action, it is of utmost importance that the delay time is of a sufficient length to eliminate spurious alarms. Activate the MENU switch four times with the magnet-stick. The current delay time will be displayed (factory setting 10 sec for Classic Mode and 2 sec for Enhanced Mode). Activating the UP switch (▲) will increment the delay time by 1 sec.

Activating the DOWN switch (▼) will decrease the delay time by 1 sec. Activating the ENTER switch without changes made, switches the unit back to Normal Operation. Activating the ENTER switch with changes made, will flash “SAVE” on the display. Confirm the save action by activating the ENTER switch once more. Activating the MENU switch while “SAVE” is flashing, will discard the save and switch the unit back to Normal Operation. If ENTER was activated the unit will display “DONE” to confirm that the changes have been saved and return to Normal Operation.

The operator can change the delay time and if desired move to the next item (alarm relay energized/de-energized) in the menu structure by activating the MENU switch straight after the change. The change will be saved at a later stage by activating the ENTER switch at any point in the menu structure. If no switch is activated for 60 seconds the detector will return to normal operation without saving the changed settings.

Delay Time Settings

Display	D 0	D 1	D 2	D 3	....	D 240
Delay Time	0 Sec	1 Sec	2 Sec	3 Sec	....	240 Sec

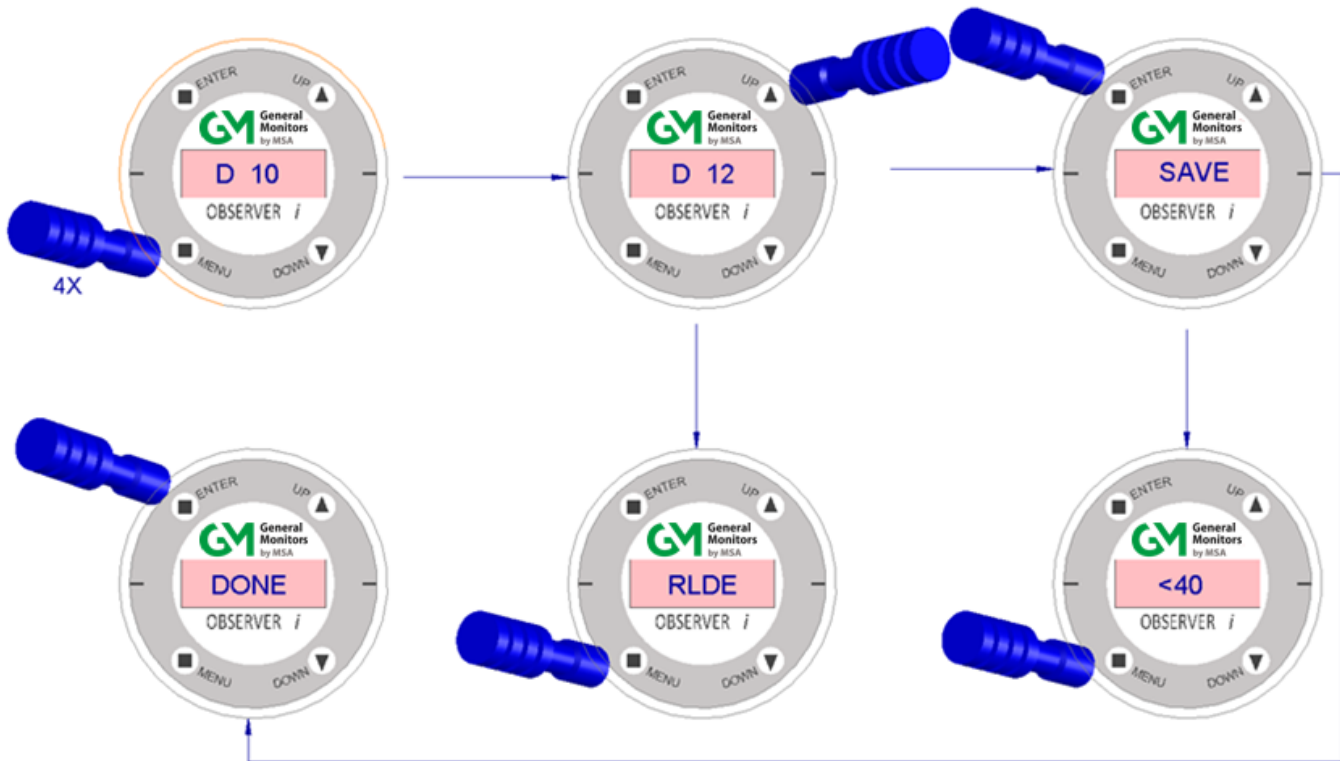

#### 4.5.6 Setting / Checking Alarm Relay Energized / De-Energized

The Alarm Relay is normally de-energized at power up of the unit. The output is an open contact. The output can be changed to closed contact at alarm by energizing the Alarm Relay.

Activate the MENU switch five times with the magnet-stick. The current Alarm Relay status will be displayed (factory setting = RLDE = de-energized). Activating the DOWN switch (▼) will switch the Alarm Relay status to energized (RL E). Activating the UP switch (▲) will switch the Alarm Relay status back to de-energized. Activating the ENTER switch without changes made, switches the unit back to Normal Operation. Activating the ENTER switch with changes made, will flash "SAVE" on the display. Confirm the save action by activating the ENTER switch once more. Activating the MENU switch while "SAVE" is flashing will discard the save and switch the unit back to Normal Operation. If ENTER was activated the unit will display "DONE" to confirm that the changes have been saved and return to Normal Operation.

The operator can change the relay energizing settings and if desired move to the next item (alarm latching ON/OFF) in the menu structure by activating the MENU switch straight after the change. The change will be saved at a later stage by activating the ENTER switch at any point in the menu structure. If no switch is activated for 60 seconds the detector will return to normal operation without saving the changed settings.

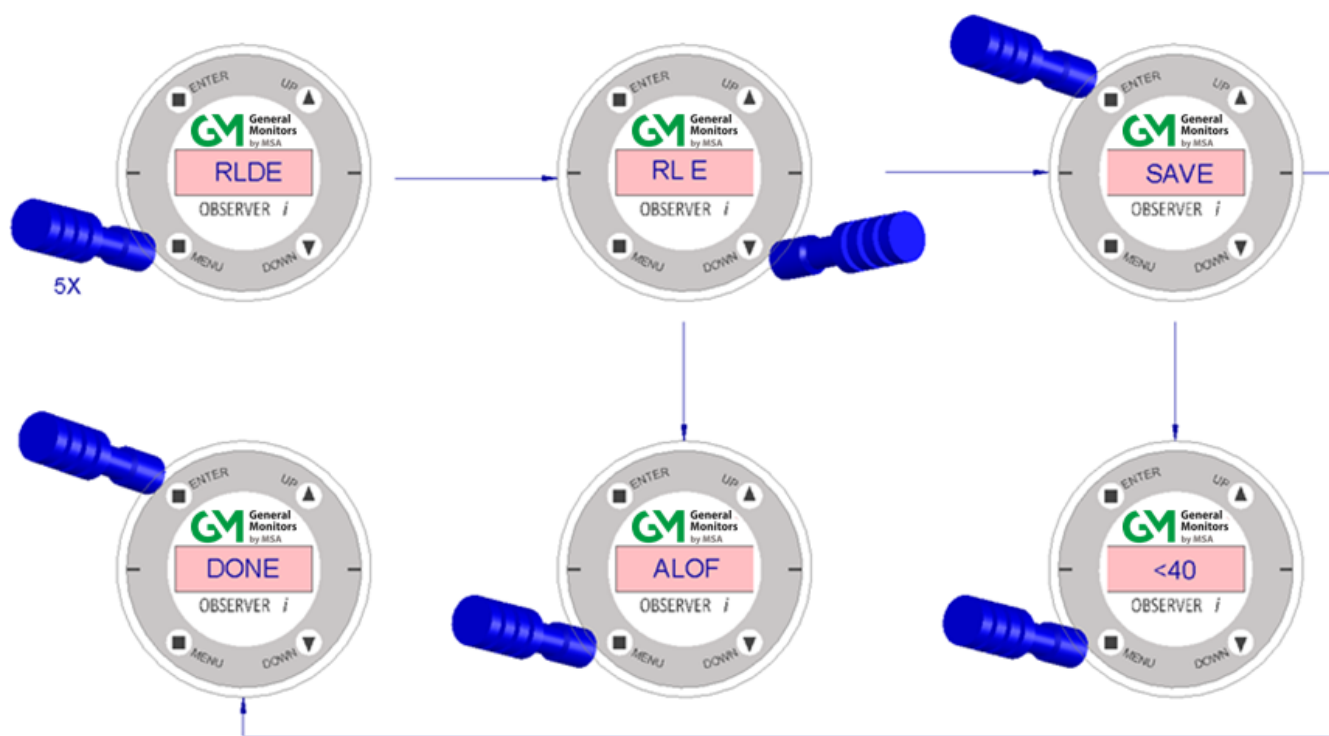

### 4.5.7 Setting / Checking Alarm Latching ON / OFF

The Alarm Latching feature gives the local operator the opportunity to latch the alarm relay output in alarm even if the sound level drops below the trigger level. The alarm latching is factory set to OFF.

Activate the MENU switch six times with the magnet-stick. The current Alarm Latching status will be displayed (factory setting = ALOF = OFF). Activating the DOWN switch (▼) will switch the Alarm Latching status to ON (ALON). Activating the UP switch (▲) will switch the Alarm Latching status back to OFF. Activating the ENTER switch without changes made, switches the unit back to Normal Operation. Activating the ENTER switch with changes made, will flash "SAVE" on the display. Confirm the save action by activating the ENTER switch once more. Activating the MENU switch while "SAVE" is flashing will discard the save and switch the unit back to Normal Operation. If ENTER was activated the unit will display "DONE" to confirm that the changes have been saved and return to Normal Operation.

The operator can change the latching settings and if desired move to the next item (Factory Default ON/OFF) in the menu structure by activating the MENU switch straight after the change. The change will be saved at a later stage by activating the ENTER switch at any point in the menu structure. If no switch is activated for 60 seconds the detector will return to normal operation / without saving the changed settings.

#### Reset a Latched Relay

Activating an UP, DOWN, or Enter magnet will reset a latched relay. The relay will not reset if an alarm condition is still present.

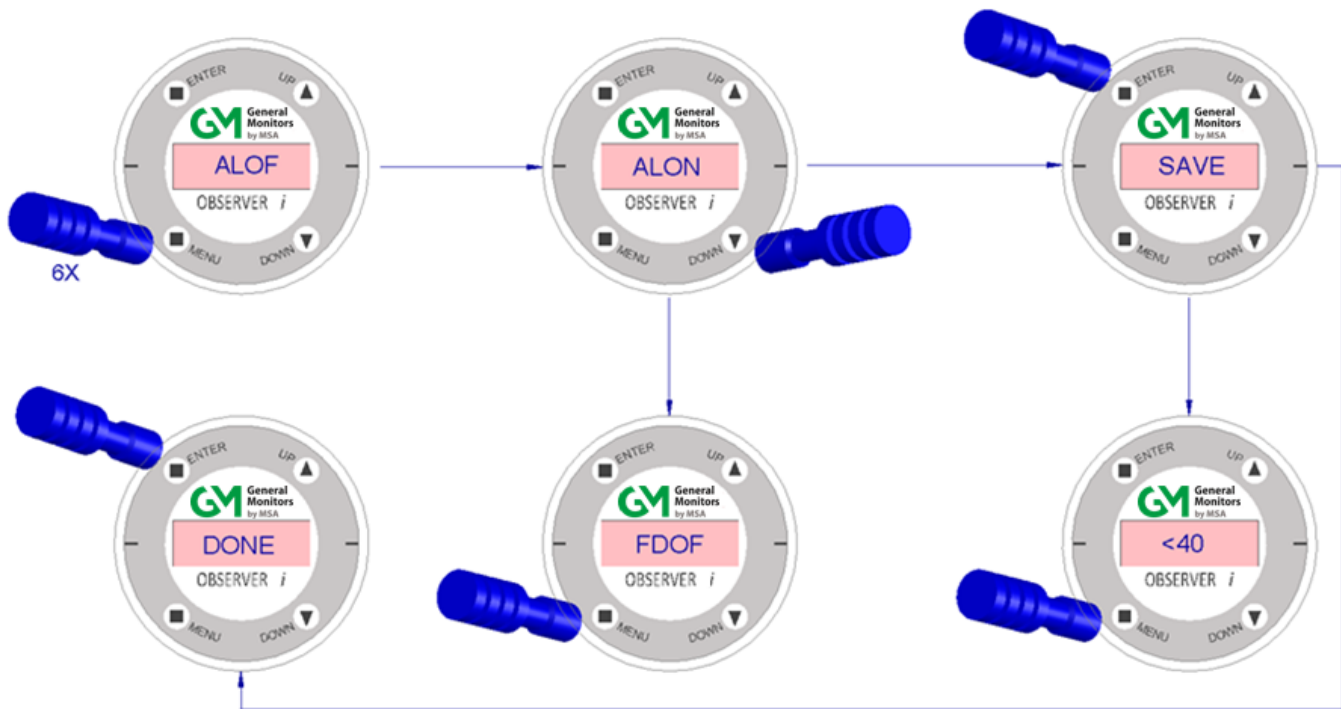

#### 4.5.8 Setting / Checking Factory Default ON / OFF

The Factory Default command gives the local operator the opportunity to return all settings to factory default.

Activate the MENU switch seven times with the magnet-stick. Factory Default OFF (FDOF) will be displayed. Activating the DOWN switch (▼) will switch the Factory Default ON. Activating the UP switch (▲) will switch the Factory Default OFF. Activating the ENTER switch without changing the status to ON, switches the unit back to Normal Operation. Activating the ENTER switch having changed the status to ON, will flash “SAVE” on the display. Confirm the save action by activating the ENTER switch once more. Activating the MENU switch while “SAVE” is flashing will discard the save and switch the unit back to Normal Operation. If ENTER was activated the unit will display “DONE” to confirm that all settings have been returned to the Factory Default and return to Normal Operation. Activating the MENU switch a 12th time will switch the unit to Normal Operation, if any changes were made in previous menu items (HazardWatch Mode ON/OFF) the unit will flash “SAVE” on the display. Confirm the save by activating the ENTER switch or discard the save by activating the MENU switch once more. If no switch is activated for 60 seconds the detector will return to normal operation without saving the changed settings.

The Observer i factory default settings are as follows:

*Table 3 Dual Modbus Configuration Default Settings*

Feature	Setting
Modbus 1	Address 1, 8-N-1, 19200 baud
Modbus 2	Address 1, 8-N-1, 19200 baud
ANN Sensitivity Level	59 dB for Enhanced Mode FQHI
Trigger Delay	2 seconds
Alarm Relay – Energized / De-Energized	De-Energized
Alarm Relay – Latched / Un-Latched	Un-Latched
HART Enable	(Disabled)
HART Current	(Disabled)

*Table 4 Single Modbus + HART Configuration Default Settings*

Feature	Setting
Modbus 1	Address 1, 8-N-1, 19200 baud
Modbus 2	(Disabled)
ANN Sensitivity Level	59 dB for Enhanced Mode FQHI
Trigger Delay	2 seconds
Alarm Relay – Energized / De-Energized	De-Energized
Alarm Relay – Latched / Un-Latched	Un-Latched
HART Enable	Enabled
HART Current	3.5 mA for High Range 1.25 mA for Low Range

**NOTE:** There are three other ways to restore the default values. Both Modbus and HART can send a command. The alarm reset switch can restore the default values (see remote reset switch).

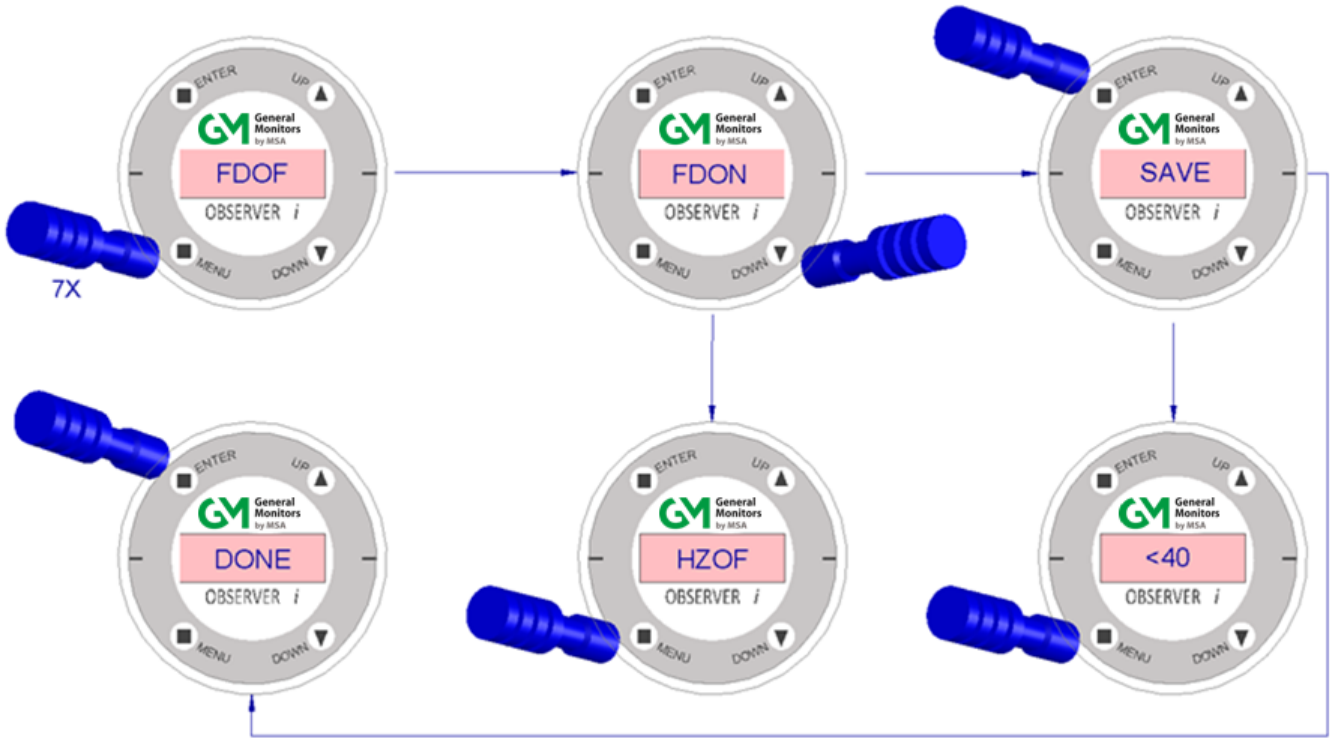

#### 4.5.9 Switching HazardWatch Mode ON/OFF

Activate the MENU switch eight times with magnet stick. The factory default setting (HZOF) will be displayed. Activating the DOWN switch (▼) will switch the factory default ON (FD ON). Activating the UP switch (▲) will switch the factory default OFF. Activating the ENTER switch having changed the status ON/OFF, will flash “SAVE” on the display. Confirm the SAVE action by activating the ENTER switch once more. Activating the MENU switch while “SAVE” is flashing, will discard the SAVE and switch the unit back to normal operation. If ENTER is activated the unit will display “DONE” to confirm that the changes have been saved and return to normal operation. The operator can change the HazardWatch settings and if desired move to the next item (HART ON/OFF) in the menu structure by activating the MENU switch straight after the change. The change will be saved at a later stage by activating the ENTER switch at any point in the menu structure. If no switch is activated for 60 seconds, the detector will return to normal operation without saving the changed settings.

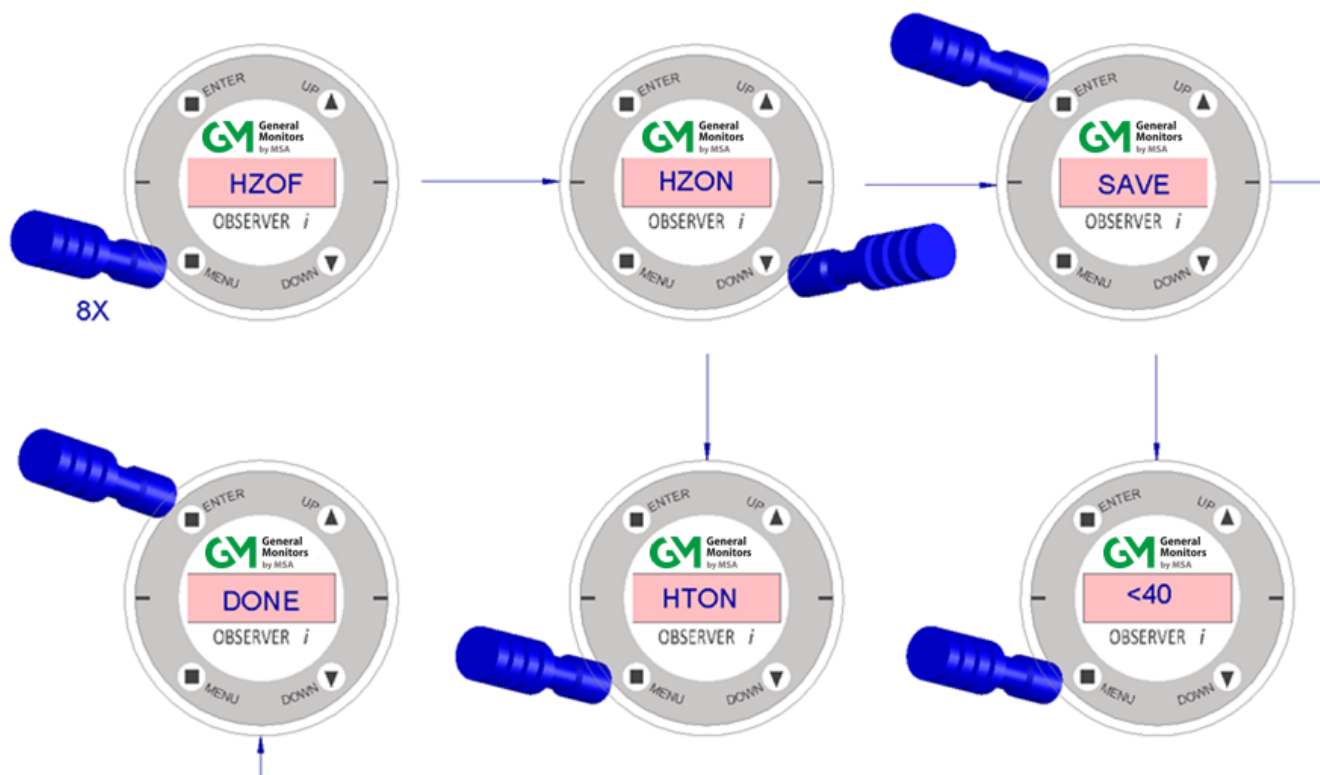

### 4.5.10 HART ON/OFF

The Observer i provides the operator the ability to field configure the unit to either Enable/Disable HART communication. When HART communication is enabled, the Observer i has the following: Single Modbus + HART. When HART is disabled, the Observer i supports Dual Modbus, but no HART.

Activate the MENU switch nine times with the magnet stick. The factory default setting (HTON) will be displayed. Activating the UP switch (▲) will switch the factory Default OFF. Activating the DOWN switch (▼) will switch the factory default ON. Activating the ENTER switch having changed the status ON/OFF, will flash “SAVE” on the display. Confirm the SAVE action by activating the ENTER switch once more. Activating the MENU switch while “SAVE” is flashing, will discard the SAVE and switch the unit back to normal operation. If ENTER is activated the unit will display “DONE” to confirm that the changes have been saved and return to normal operation. The operator can change the HART setting and if desired move to the next item (HART Minimum Analog Output Range) in the menu structure by activating the MENU switch straight after the change. The change will be saved at a later stage by activating the ENTER switch at any point in the menu structure. If no switch is activated for 60 seconds, the detector will return to normal operation without saving the changed settings.

By disabling the HART (HTOF), the channel two option of the Modbus setting will be accessed.

If HART is Enabled (HTON): Activating the MENU twelve times will switch the unit to Normal Operation.

If HART is Disabled (HTOF): Activating the MENU fifteen times will switch the unit to Normal Operation.

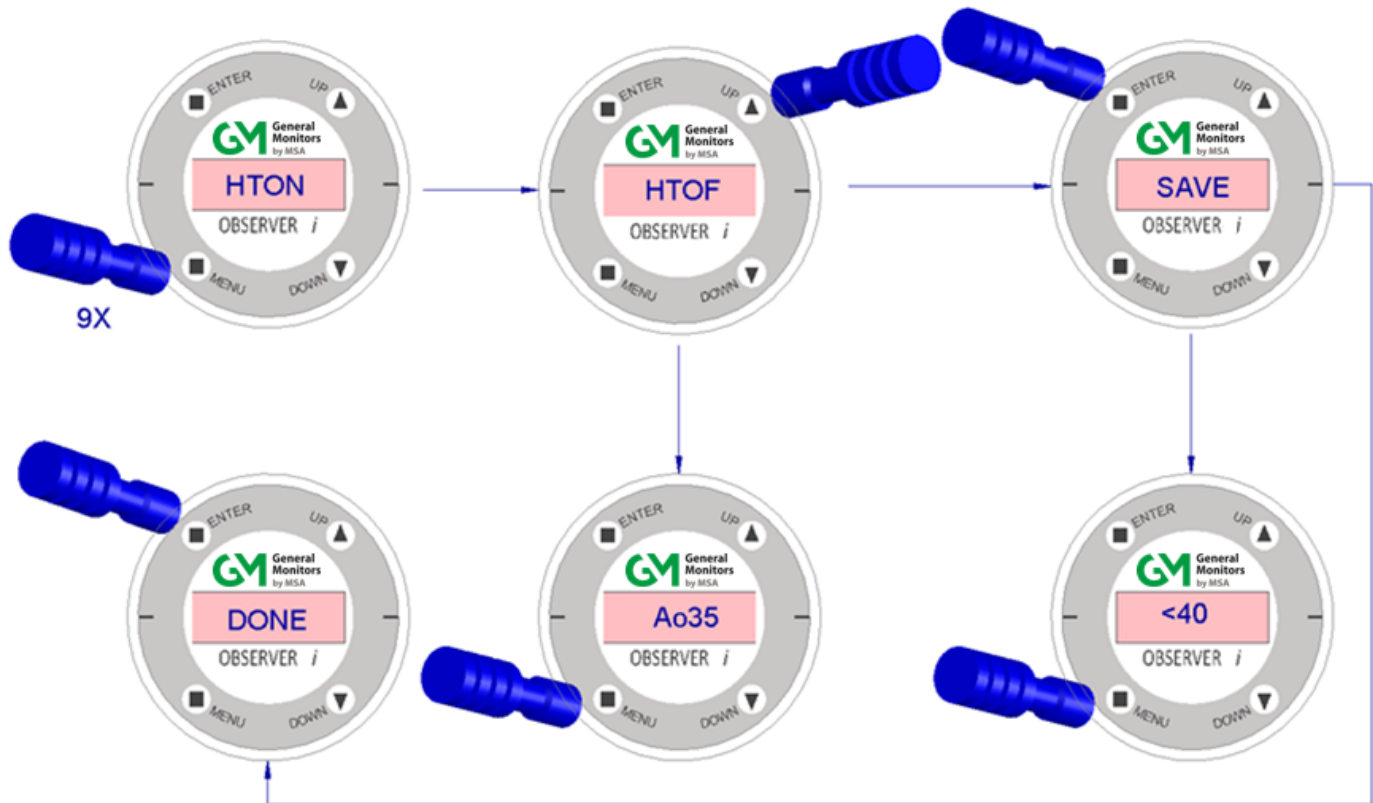

#### 4.5.11 Setting HART Analog Output Range (only if HART is on)

The Observer *i* provides the operator the ability to field-configure the unit to either 3.5 mA or 1.25 mA minimum HART analog output.

Activate the MENU switch ten times with the magnet stick. The factory default setting (Ao35) will be displayed. Activating the UP switch (▲) and DOWN switch (▼) will switch to select the minimum current. Activating the ENTER switch having changed the status 35/12, will flash “SAVE” on the display. Confirm the SAVE action by activating the ENTER switch once more. Activating the MENU switch while “SAVE” is flashing, will discard the SAVE and switch the unit back to normal operation. If ENTER is activated the unit will display “DONE” to confirm that the changes have been saved and return to normal operation. The operator can change the HART setting and if desired move to the next item (Baud Rate) in the menu structure by activating the MENU switch straight after the change. The change will be saved at a later stage by activating the ENTER switch at any point in the menu structure. If no switch is activated for 60 seconds, the detector will return to normal operation without saving the changed settings.

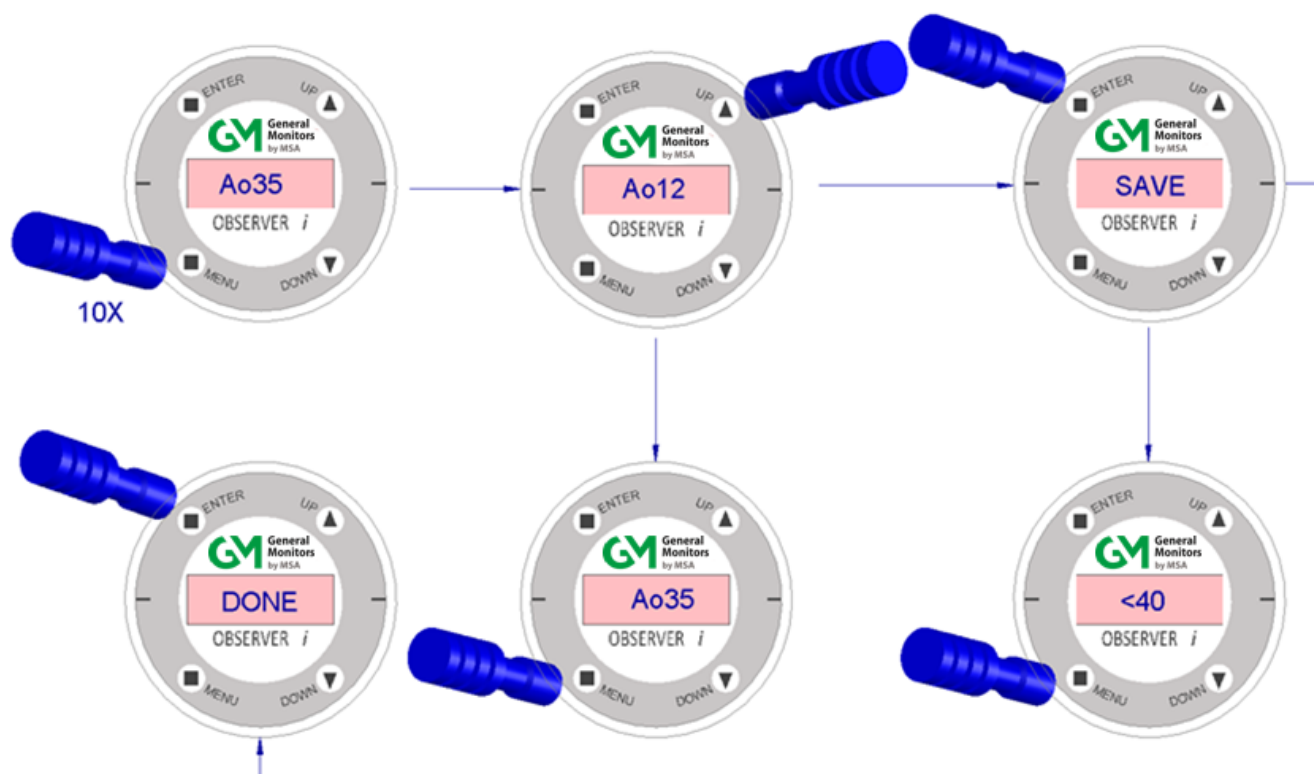

4.5.12 Modbus Setting: Baud (Channel One)

Activating the MENU switch eleven times will display the default setting Baud rate “B192” (19200). Using the UP/DOWN switches, the Baud Rate can be selected for the Modbus communication interface. The selectable Baud Rates are 57600, 38400, 19200, 9600, 4800 or 2400 bits per second. Activating the ENTER switch having changed the status ON/OFF, will flash “SAVE” on the display. Confirm the SAVE action by activating the ENTER switch once more. Activating the MENU switch while “SAVE” is flashing, will discard the SAVE and switch the unit back to normal operation. If ENTER is activated the unit will display “DONE” to confirm that the changes have been saved and return to normal operation. The operator can change the Baud rate and if desired move to the next item (Format) in the menu structure by activating the MENU switch straight after the change. The change will be saved at a later stage by activating the ENTER switch at any point in the menu structure. More info for Modbus protocol is available in [6 Modbus Digital Interface](#). If no switch is activated for 60 seconds, the detector will return to normal operation without saving the changed settings.

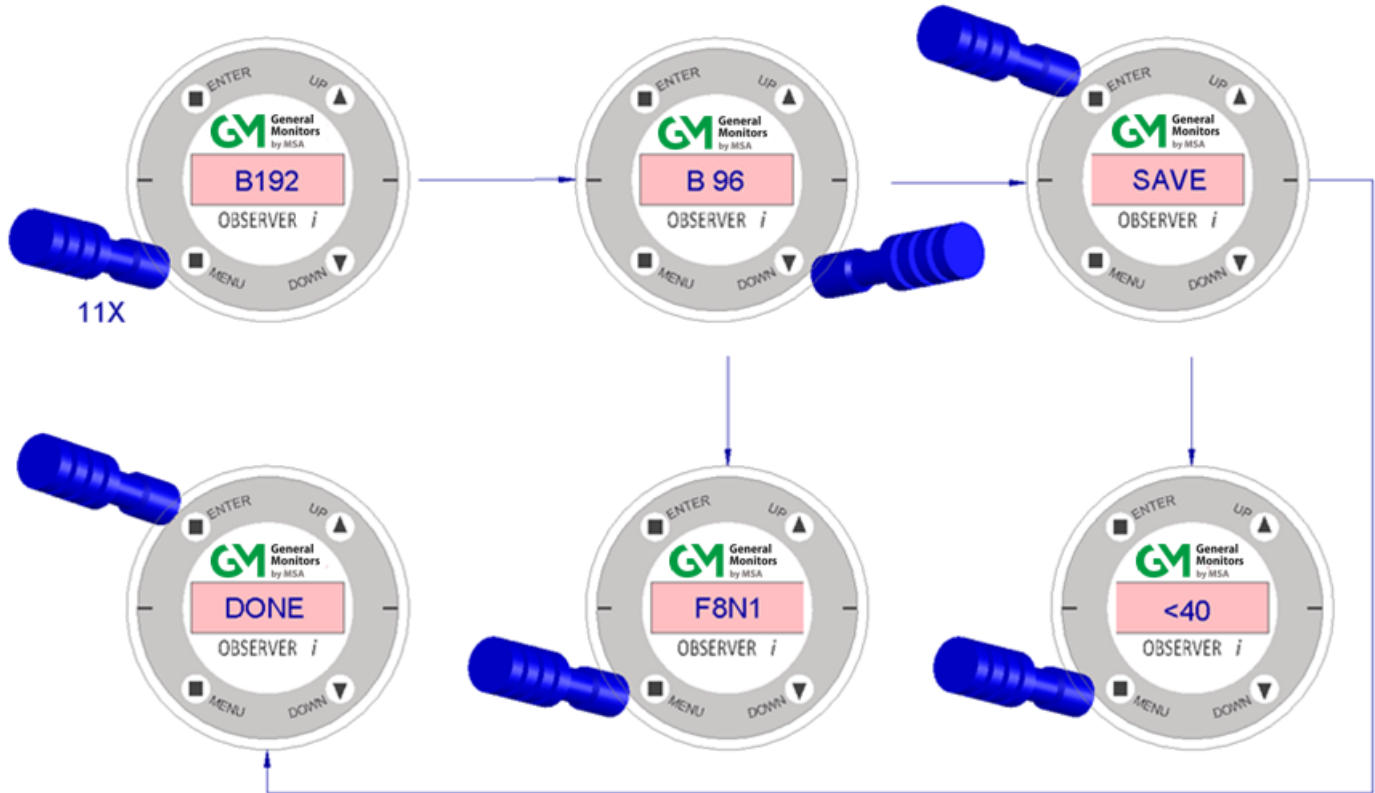

#### 4.5.13 Modbus Setting: Format (Channel One)

Activating the MENU switch twelve times will display the default Modbus setting Format “F8N1” (8-N-1). Using the UP/DOWN switches, the format can be selected for the Modbus communication interface. The selectable formats are: 8-N-1, 8-E-1, 8-O-1, or 8-N-(bits- parity-stop bits).

Activating the ENTER switch having changed the status ON/OFF, will flash “SAVE” on the display. Confirm the SAVE action by activating the ENTER switch once more. Activating the MENU switch while “SAVE” is flashing, will discard the SAVE and switch the unit back to normal operation. If ENTER is activated the unit will display “DONE” to confirm that the changes have been saved and return to normal operation. The operator can change the format settings and if desired move to the next item (Address) in the menu structure by activating the MENU switch straight after the change. The change will be saved at a later stage by activating the ENTER switch at any point in the menu structure. If no switch is activated for 60 seconds, the detector will return to normal operation without saving the changed settings.

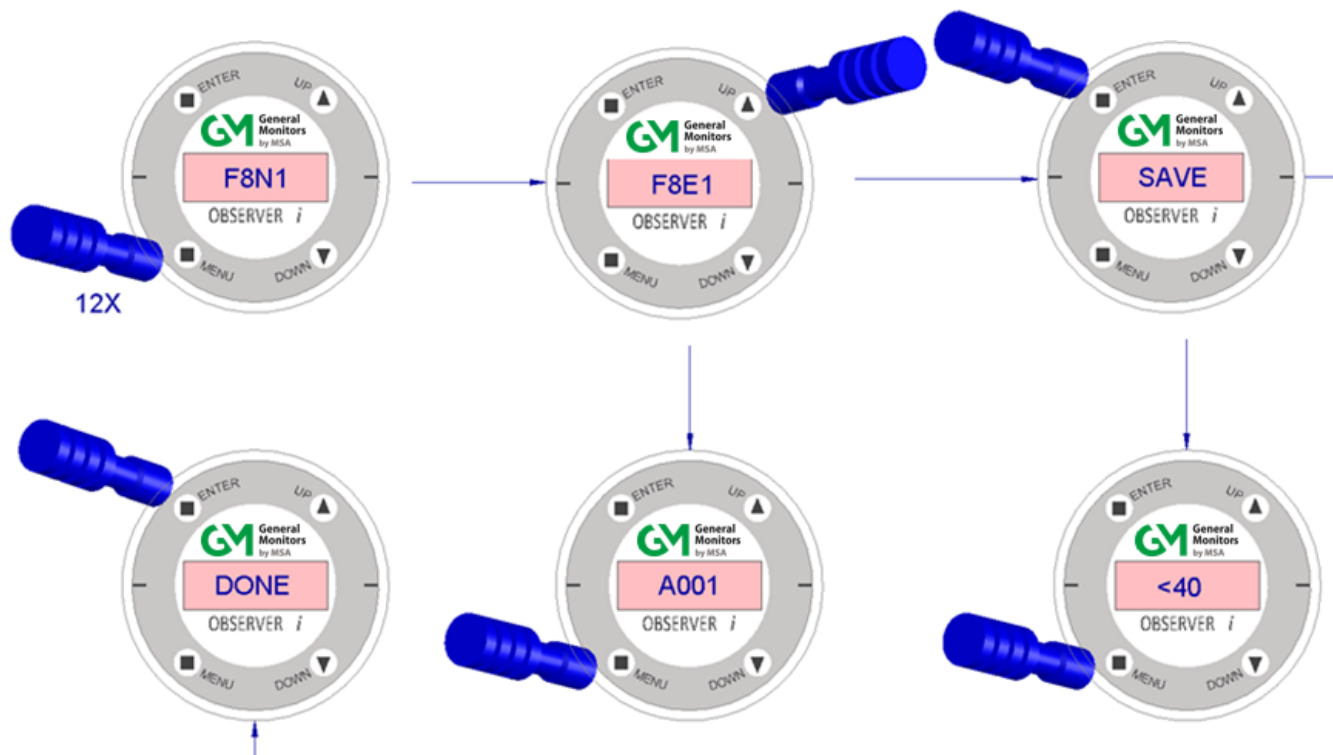

4.5.14 Modbus Setting: Address (Channel One)

Activating the MENU switch thirteen times will display the current Address of the Modbus (Factory setting is 001). Activating the UP switch (▲) will increment the address and activating the DOWN switch (▼) will decrement the address (the range is 1 to 247). Activating the ENTER switch having changes made, will flash. “SAVE” on the display. Confirm the SAVE action by activating the ENTER switch once more. Activating the MENU switch while “SAVE” is flashing, will discard the SAVE and switch the unit back to normal operation. If ENTER is activated the unit will display “DONE” to confirm that the changes have been saved and return to Normal operation. The operator can change the address settings time and if desired move to the next item (Baud Rate) in the menu structure by activating the MENU switch straight after the change. The change will be saved at a later stage by activating the ENTER switch at any point in the menu structure. More info for Modbus protocol is available in [6 Modbus Digital Interface](#). If no switch is activated for 60 seconds the detector will return to normal operation without saving the changed settings.

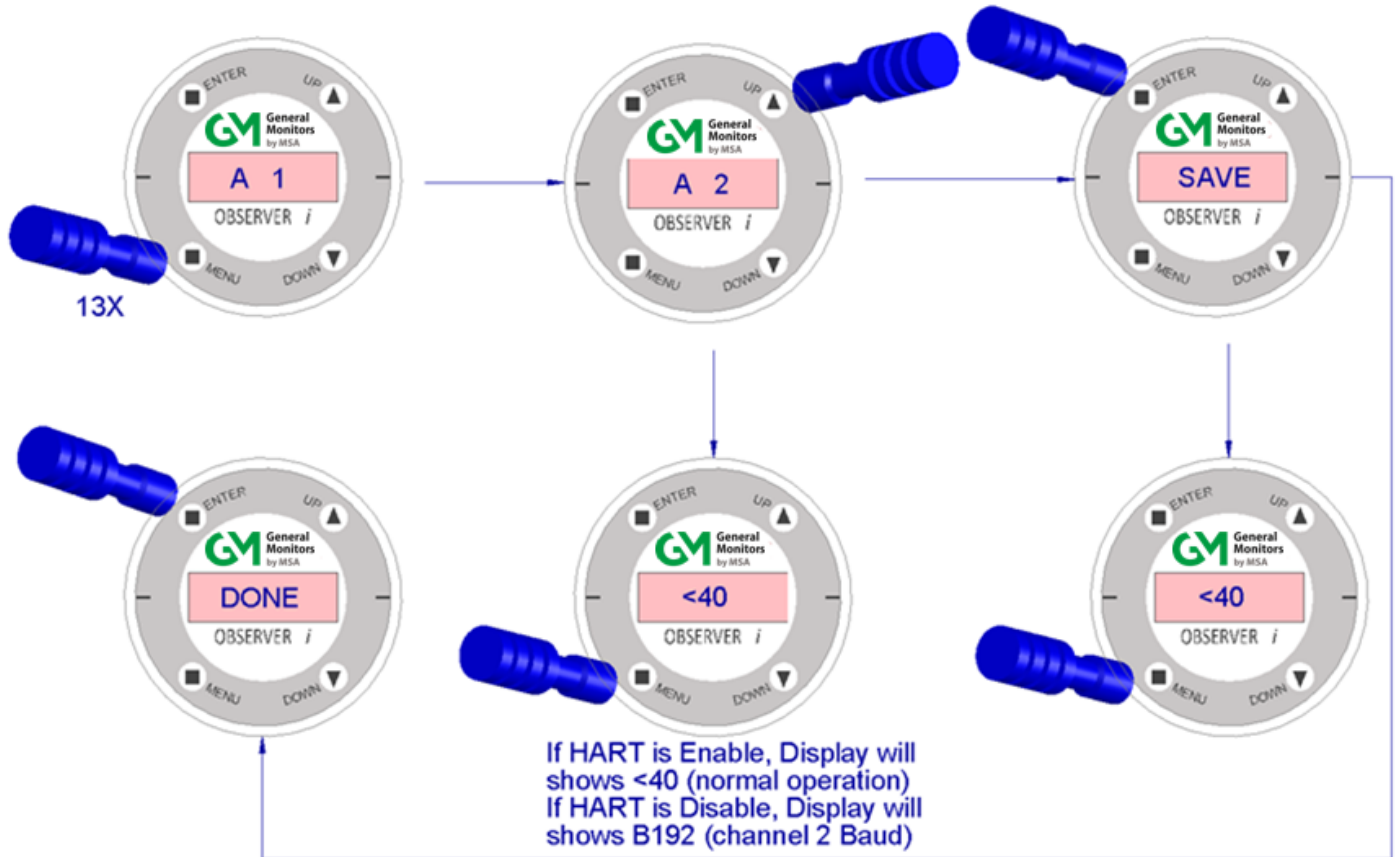

If HART is enabled (factory default is ON) Channel 2 will not appear. Activating the MENU thirteen times will switch the unit to normal operation.

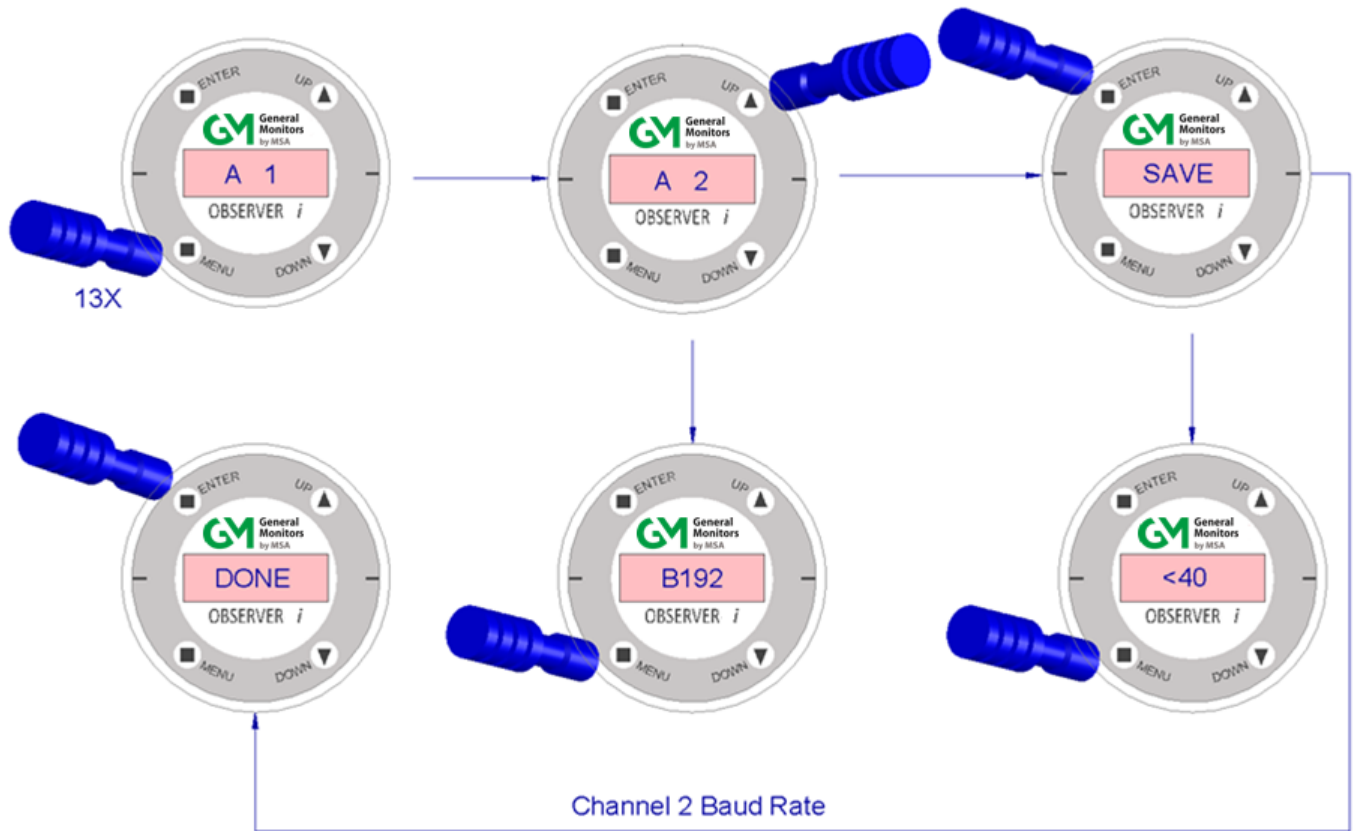

If HART is disabled, the baud rate for Channel 2 will appear.

**NOTE:** If HART is enabled the following channel two items will not appear.

### 4.5.15 Baud (Channel Two)

Activating the MENU switch fourteen times will display the default setting baud rate “B192” (19200). Using the UP/DOWN switches, the Baud Rate can be selected for the Modbus communication interface. The selectable Baud Rates are 57600, 38400, 19200, 9600, 4800 or 2400 bits per second. Activating the ENTER switch having changed the status ON/OFF, will flash “SAVE” on the display. Confirm the SAVE action by activating the ENTER switch once more. Activating the MENU switch while “SAVE” is flashing, will discard the SAVE and switch the unit back to normal operation. If ENTER is activated the unit will display “DONE” to confirm that the changes have been saved and return to normal operation. The operator can change the Baud rate and if desired move to the next item (Format) in the menu structure by activating the MENU switch straight after the change. The change will be saved at a later stage by activating the ENTER switch at any point in the menu structure. More info for Modbus protocol is available in [6 Modbus Digital Interface](#). If no switch is activated for 60 seconds, the detector will return to normal operation without saving the changed settings.

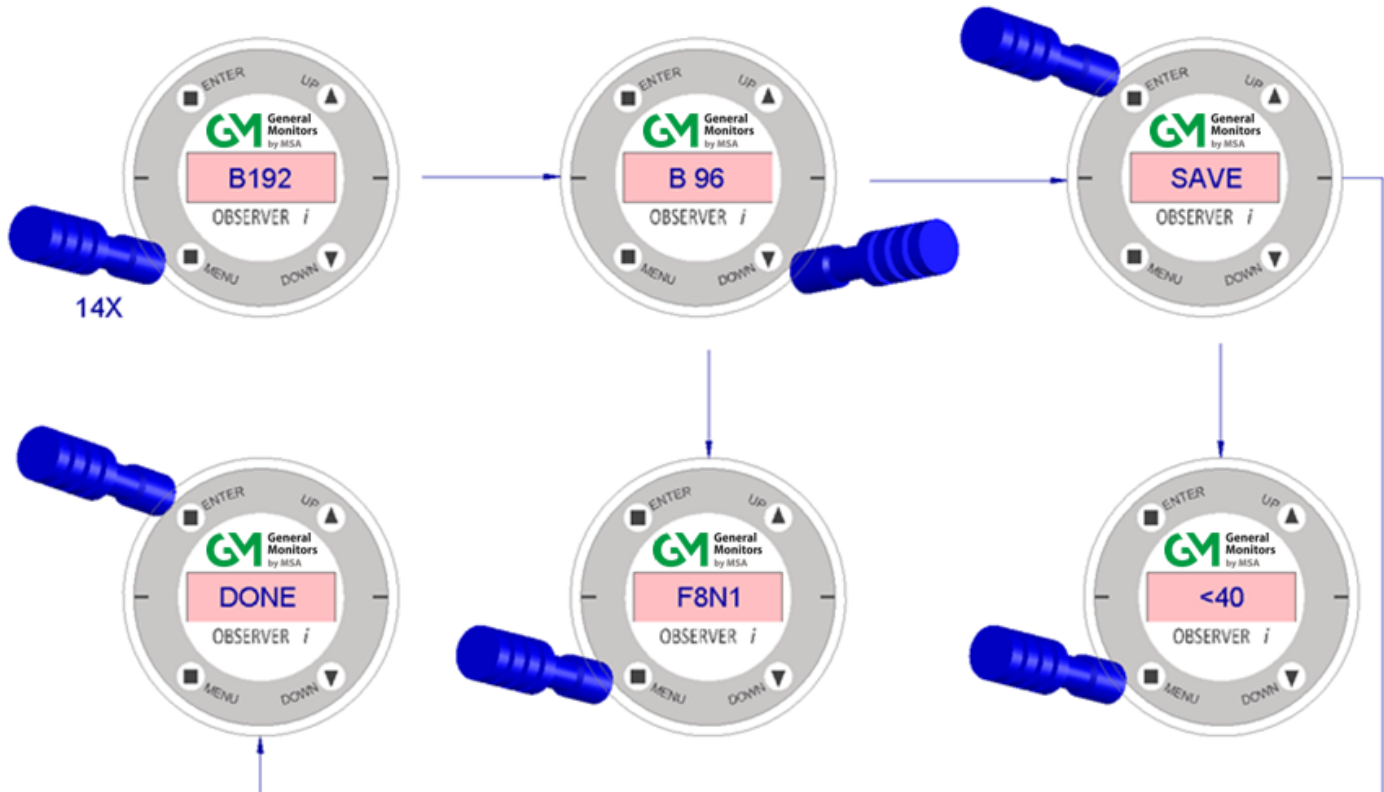

#### 4.5.16 Format (Channel Two)

Activating the MENU switch fifteen times will display the default setting Format “F8N1” (8-N-1). Using the UP/DOWN switches, the Format can be selected for the Modbus communication interface.

The selectable Formats are:

8-N-1, 8-E-1, 8-O-1, or 8-N-(bits- parity-stop bits).

Activating the ENTER switch by changing the status ON/OFF, will flash “SAVE” on the display. Confirm the SAVE action by activating the ENTER switch once more. Activating the MENU switch while “SAVE” is flashing, will discard the SAVE and switch the unit back to normal operation. If ENTER is activated, the unit will display “DONE” to confirm that the changes have been saved and return to normal operation. The operator can change the format settings and if desired move to the next item (Address) in the menu structure by activating the MENU switch straight after the change. The change will be saved at a later stage by activating the ENTER switch at any point in the menu structure. If no switch is activated for 60 seconds, the detector will return to normal operation without saving the changed settings.

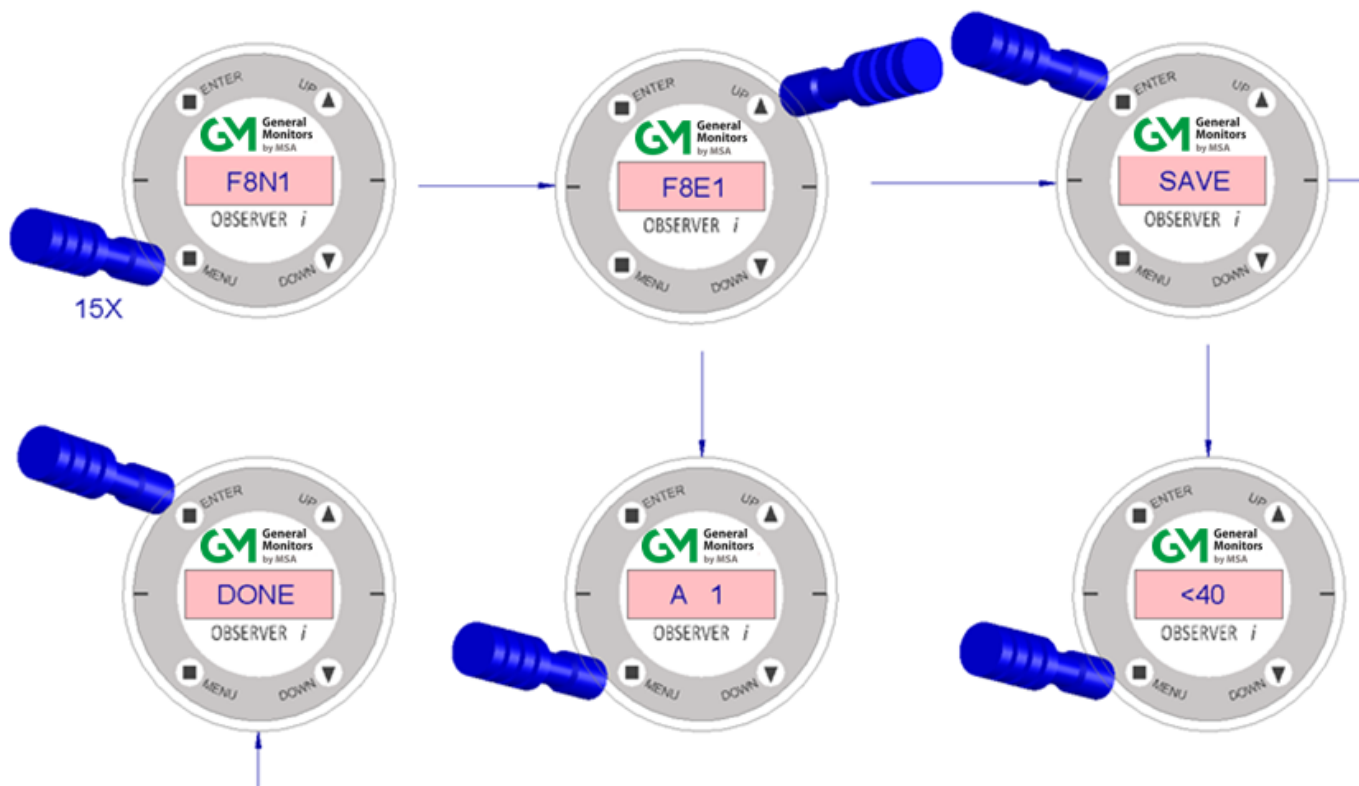

**4.5.17 Address (Channel Two)**

Activating the MENU switch sixteen times will display the Channel 2 current Address of the Modbus (Factory setting is 001). Activating the UP switch (▲) will increment the address and activating the DOWN switch (▼) will decrement the address the range is 1 to 247. Activating the ENTER switch having changes made, will flash. “SAVE” on the display. Confirm the SAVE action by activating the ENTER switch once more. Activating the MENU switch while “SAVE” is flashing, will discard the SAVE and switch the unit back to normal operation. If ENTER is activated the unit will display “DONE” to confirm that the changes have been saved and return to Normal operation. More info for Modbus protocol is available in [6 Modbus Digital Interface](#). If no switch is activated for 60 seconds the detector will return to normal operation without saving the changed settings.

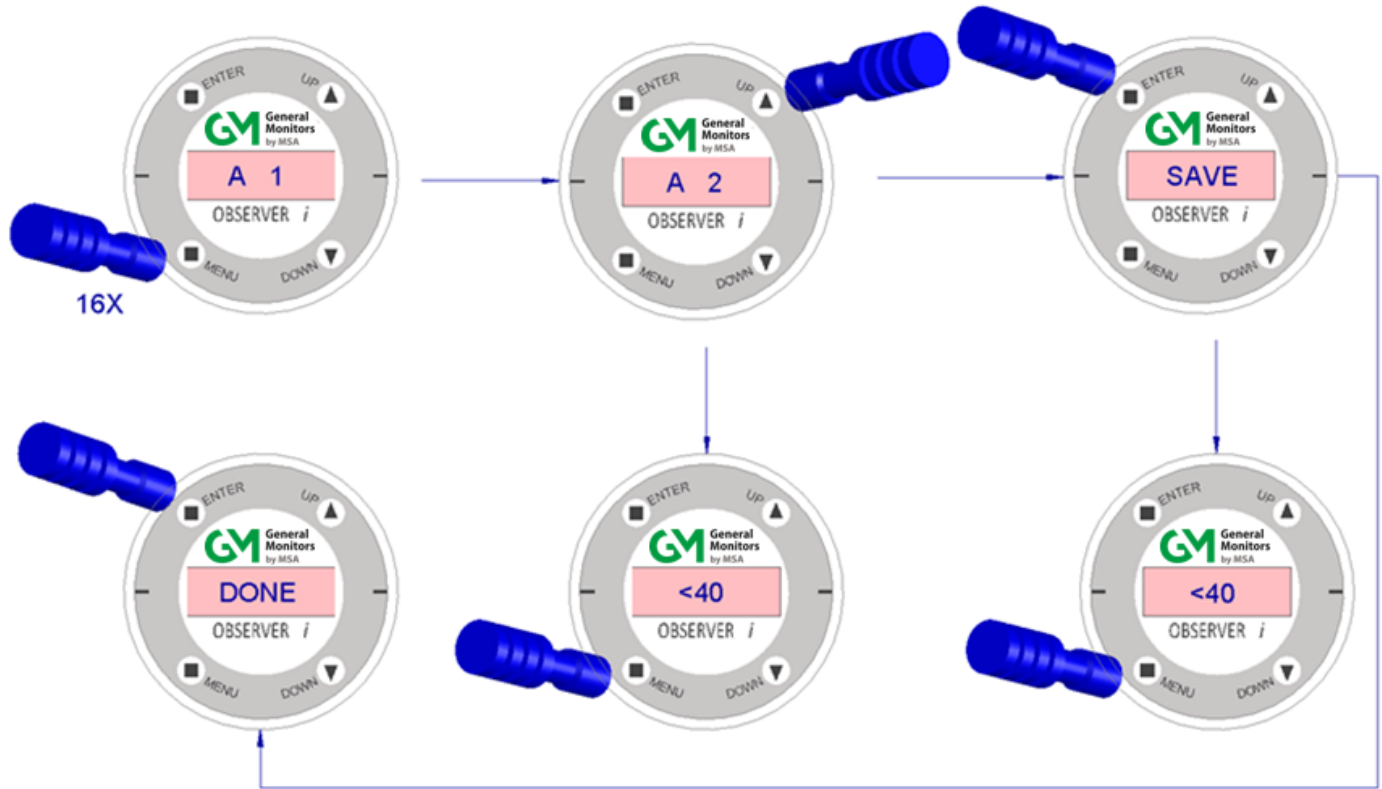

Activating the MENU fifteen times will switch the unit to normal operation.

**4.5.18 Loop Test ON/OFF (LTON/LTOF)**

Activating the DOWN switch for 3 seconds will turn on (LTON) the Loop Test function for the Observer i (in Enhanced Mode only). The loop test communicates to the Observer i that the 1701 Test and Calibration unit will be used to test the detector while in Enhanced Mode. The ANN needs to be told that this is a test in order for the 1701 to perform its test function. The unit reverts back to the default of LTOF after 5 minutes. The purpose of this is to permit the 1701 when in “Step Test and Delay Test” to activate the Observer i.

## 5 Function Test, Gain Test and Calibration

The Observer i can be tested with the 1701 Test and Calibration unit providing traceable test and calibration.

### 5.1 1701 Portable Test and Calibration Unit

The 1701 Portable Test and Calibration Unit (1701) provides a traceable gain test and calibration of all General Monitors ultrasonic gas leak detectors.

**NOTE:** The 1701 Test and Calibration unit is calibrated itself, according to an international traceable reference, and comes with a calibration certificate.

The General Monitors ultrasonic gas leak detectors are calibrated at the factory, but if plant regulations require documentation, the 1701 can be used. Calibration of the Observer i is only needed when the unit is more than  $\pm 3$  dB out of tolerance. This can be verified by doing a Gain Test on the unit. The Observer i Gain Test is one of the test sequences of the 1701. Calibration is performed with a calibrated 1701.



### 5.2 Gain Test

Select type "Observer" on the 1701 and then select Gain Test (see the 1701 User Manual for details). Attach the 1701 onto the Observer i and activate the Gain Test by pressing the ENTER or TEST button. The 1701 will output a constant SPL of 99 dB for 8 seconds and then to 0 dB for 3 seconds. Thereafter, the SPL will return to 99 dB and the sequence will be repeated until a new SPL is selected or the test stopped. To select a new SPL, the DOWN button should be pressed. There are four levels: 99 dB, 89 dB, 79 dB and 64 dB. The dB readout on the display of the 1701 can now be compared with that of the Observer i.

### 5.3 Calibration

Select type “Observer” on the 1701 and then select Calibration (see the 1701 User Manual for details). Attach the 1701 onto the Observer i. Set the Observer i into Calibration mode by holding the magnet stick on the ENTER switch for more than 3 seconds. The Observer i will display a flashing “CAL”. Verify the need for calibration by activating the ENTER switch one more time. The Observer i will now display a flashing “1701”. This indicates that the Observer i is ready for calibration and is awaiting communication from the 1701 unit.

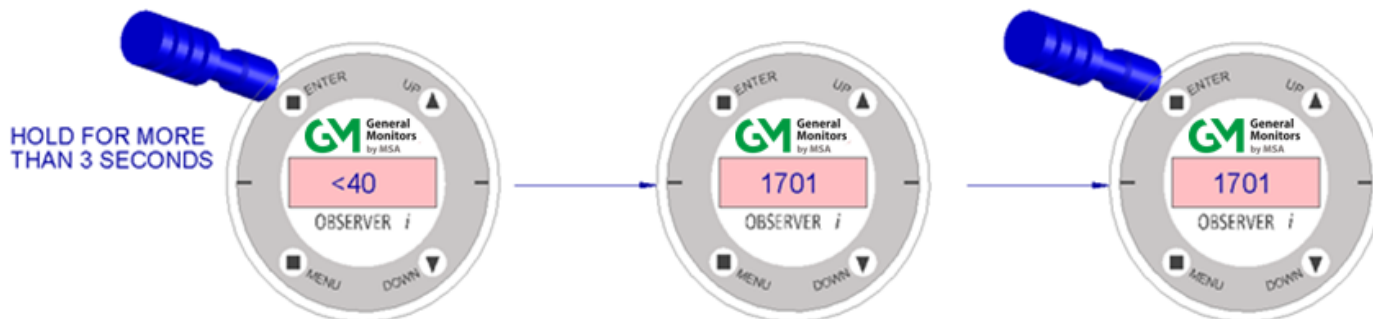

Activate the calibration by pressing the ENTER or TEST button on the 1701. The calibration sequence is automatic. If communication between the Observer i and the 1701 is broken, “EER” will be displayed and the unit will return to normal operation. If the calibration sequence was completed successfully and adjustments were made, “ADJ” will be displayed for 2 seconds and the unit will return to normal operation. If the calibration sequence was completed successfully and adjustments were not necessary “OK” will be displayed for 2 seconds and the unit will return to normal operation. A calibration event will be recorded.

Calibration Routine

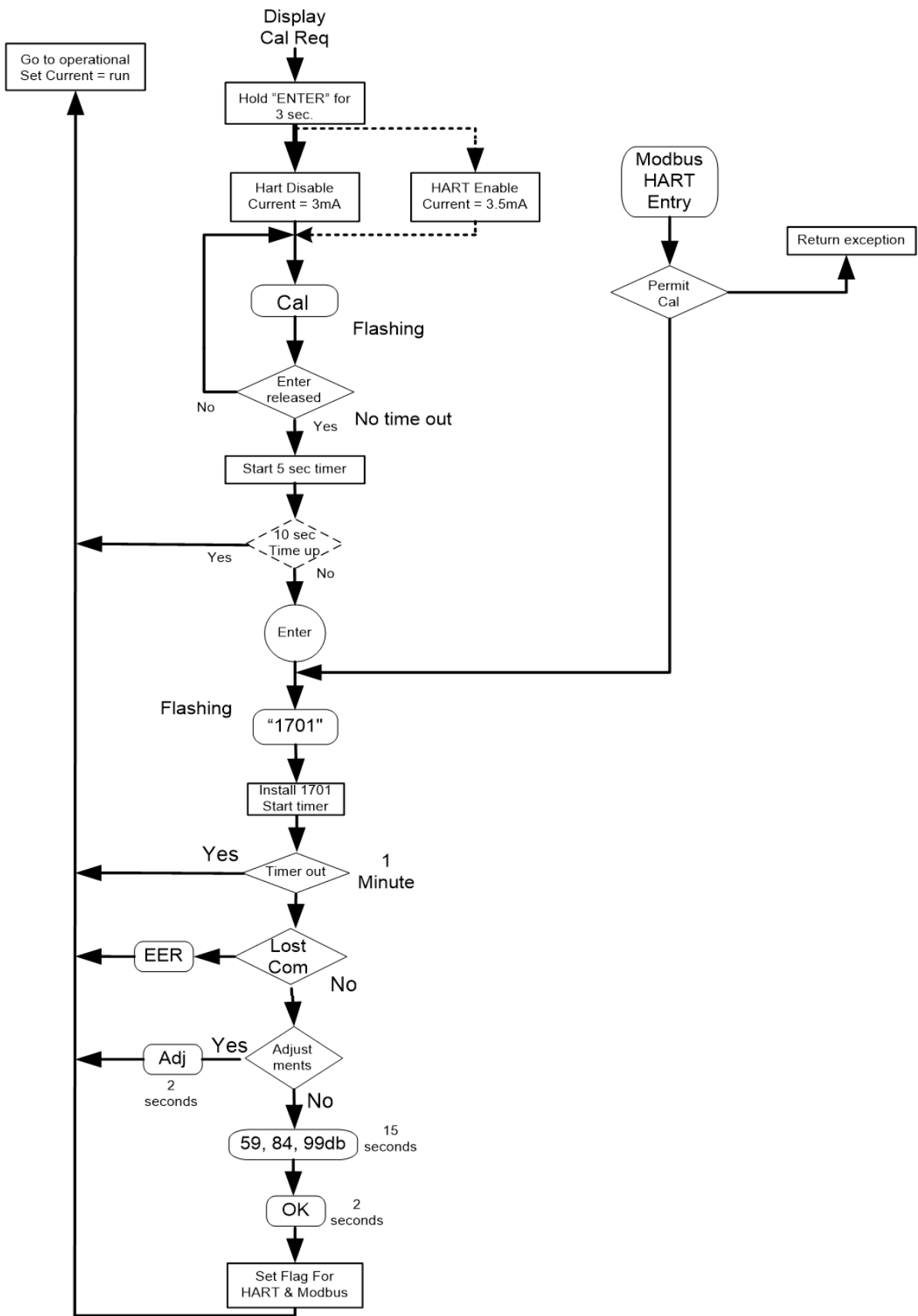

## 6 Modbus Digital Interface

The Observer i is available in a Dual Modbus configuration and in a Single Modbus + HART configuration. For the Dual Modbus configuration, two independent Modbus communication channels are provided and referred to as Comm 1 and Comm 2. For the Single Modbus + HART configuration, the Modbus channel is referred to as Comm 1.

**NOTE:** The Dual Modbus configuration disables HART communication.

### 6.1 Baud Rate

The Baud Rate is a selectable setting via the Modbus communications interface. The selectable baud rates are 57600, 38400, 19200, 9600, 4800, or 2400 bps.

### 6.2 Data Format

The Data Format is a selectable setting via the Modbus communications interface. The selectable data formats are as follows:

Table 5 Data Format

Data Bits	Parity	Stop Bit	Format
8	None	1	8-N-1
8	Even	1	8-E-1
8	Odd	1	8-O-1
8	None	2	8-N-2

### 6.3 Modbus Read Status Protocol (Query/Response)

#### 6.3.1 Modbus Read Query Message

Table 6 Modbus Query Messages

Byte	Modbus	Range	Referenced to Observer i
1 <sup>st</sup>	Slave Address	1-247 *	Observer i ID (Address) (X = 0 or 1 Model Type)
2 <sup>nd</sup>	Function Code	03	Read Holding Registers
3 <sup>rd</sup>	Starting Address Hi**	00	Not Used by Observer i
4 <sup>th</sup>	Starting Address Lo**	00-FF (Hex)	Observer i Commands
5 <sup>th</sup>	No. of Registers Hi	00	Not Used by Observer i
6 <sup>th</sup>	No. of Registers Lo	01	No. of 16 Bit Registers
7 <sup>th</sup>	CRC Lo	00-FF (Hex)	CRC Lo Byte
8 <sup>th</sup>	CRC Hi	00-FF (Hex)	CRC Hi Byte

\* Address 0 is reserved for broadcast mode and is not supported at this time.

\*\* Start Address can be a maximum of 247 Address Locations (0000-0x00F7).

#### 6.3.2 Modbus Read Response Message

Table 7 Modbus Read Response Messages

Byte	Modbus	Range	Referenced to Observer i
1 <sup>st</sup>	Slave Address	1-247* (Decimal)	Observer i ID (Address)
2 <sup>nd</sup>	Function Code	03 or 04	Read Holding Registers
3 <sup>rd</sup>	Byte Count	02 – FF (Hex)	No. of Data Bytes
4 <sup>th</sup>	Data Hi	00-FF (Hex)	Observer i Hi Byte Status Data
5 <sup>th</sup>	Data Lo	00-FF (Hex)	Observer i Lo Byte Status Data
6 <sup>th</sup>	CRC Lo	00-FF (Hex)	CRC Lo Byte
7 <sup>th</sup>	CRC Hi	00-FF (Hex)	CRC Hi Byte

\* Address 0 is reserved for broadcast mode and will not be supported at this time.

## 6.4 Modbus Write Command Protocol (Query/Response)

### 6.4.1 Modbus Write Query Message

Table 8 Modbus Write Query Message

Byte	Modbus	Range	Referenced to Observer i
1 <sup>st</sup>	Slave Address	1-247* (Decimal)	Observer i ID (Address)
2 <sup>nd</sup>	Function Code	06	Preset Single Register
3 <sup>rd</sup>	Register Address Hi**	00	Not used by Observer i
4 <sup>th</sup>	Register Address Lo**	00-FF (Hex)	Observer i Commands
5 <sup>th</sup>	Preset Data Hi	00-FF (Hex)	Observer i Hi Byte Command Data
6 <sup>th</sup>	Preset Data Lo	00-FF (Hex)	Observer i Lo Byte Command Data
7 <sup>th</sup>	CRC Lo	00-FF (Hex)	CRC Lo Byte
8 <sup>th</sup>	CRC Hi	00-FF (Hex)	CRC Hi Byte

\* Address 0 is reserved for broadcast mode and is not supported at this time.

\*\* Start Address can be a maximum of 247 Address Locations (0000-0x00F7).

### 6.4.2 Modbus Write Response Message

Table 9 Modbus Write Response Message

Byte	Modbus	Range	Referenced to Observer i
1 <sup>st</sup>	Slave Address	1-247* (Decimal)	Observer i ID (Address)
2 <sup>nd</sup>	Function Code	06	Preset Single Register
3 <sup>rd</sup>	Register Address Hi**	00	Not used by Observer i
4 <sup>th</sup>	Register Address Lo**	00-FF (Hex)	Observer i Commands
5 <sup>th</sup>	Preset Data Hi	00-FF (Hex)	Observer i Hi Byte Command Data
6 <sup>th</sup>	Preset Data Lo	00-FF (Hex)	Observer i Lo Byte Command Data
7 <sup>th</sup>	CRC Lo	00-FF (Hex)	CRC Lo Byte
8 <sup>th</sup>	CRC Hi	00-FF (Hex)	CRC Hi Byte

\* Address 0 is reserved for broadcast mode and is not supported at this time.

\*\* Start Address can be a maximum of 247 Address Locations (0000-0x00F7).

### 6.4.3 Function Codes Supported

Function Code 03 or 04 (Read Holding Registers) is used to read status from the slave unit. Function Code 06 (Preset Single Register) is used to write a command to the slave unit.

## 6.5 Exception Responses and Exception Codes

In a normal exchange, the master device sends a query to the Observer i. The Observer i receives the query and returns a normal response to the master. If a communication error occurs, there are three possible responses from the Observer i:

1. If the Observer i does not recognize the query due to communication error, no response is returned from the Observer i and the master device will eventually process a timeout condition for the query.
2. If the Observer i receives the query but detects a communication error (CRC, etc.), no response is returned from the Observer i, and the master device will eventually process a timeout for the query.
3. An exception code is returned when the Observer i receives the query without a communication error but cannot process it due to reading or writing to a non-existent or Illegal Function Code, Illegal Command Starting Address or Register Address, or Illegal Data Value. The exception response message has two fields that differentiate it from a normal response. See the next section for more information.

### 6.5.1 Exception Responses

Table 10 Exception responses

Byte	Modbus	Range	Referenced to Observer i
1 <sup>st</sup>	Slave Address	1-247* (Decimal)	Observer i ID (Address)
2 <sup>nd</sup>	Function Code	83 or 86 (Hex)	MSB is set with Function Code
3 <sup>rd</sup>	Exception Code	01 - 06 (Hex)	Appropriate Exception Code (See below)
4 <sup>th</sup>	CRC Lo	00-FF (Hex)	CRC Lo Byte
5 <sup>th</sup>	CRC Hi	00-FF (Hex)	CRC Hi Byte

### 6.5.2 Exception Code Field

In a normal response, the Observer i returns data and status in the data field, requested in the query from the master. In an exception response, the Observer i returns an exception code in the data field, which describes the condition that caused the exception. Below is a list of exception codes that are supported by the Observer i:

Table 11 Exception Code Field

Code	Name	Description
01	Illegal Function	The function code received in the query is not an allowable action for the Observer i.
02	Illegal Data Address	The data address received in the query is not an allowable address for the Observer i.
03	Illegal Data Value	A value contained in the query data field is not an allowable value for the Observer i.
04	Slave Device Failure	An unrecoverable error occurred while the Observer i was attempting to perform the requested action.
05	Acknowledge	The Observer i has accepted the request and is processing it, but a long duration of time will be required. This response is returned to prevent a timeout error from occurring in the master.
06	Device Busy	The Observer i is engaged in processing a long-duration program command. The master should retransmit the message later when the slave is free.

## 6.6 Command Register Locations

### 6.6.1 Modbus Operational Mode Commands

See the Section number listed below and reference [6.7 Observer i Command Register Details](#) for details of each register.

**NOTE:** The Observer i has Modbus error reporting. The optional dual Modbus has error reporting for each channel. It can also provide simultaneous block mode.

Table 12 Modbus Commands

R - indicates Read Only Access      R/W - indicates Read/Write Access

Address	Name	Function	Type	I/O Range	R/W
<b>General User Registers</b>					
0x0000	Analog Output	Scaled 0-20 mA current output	Numeric Value	0 – 21.7mA expressed in mA	R
0x0001	Mode	Set/view operating mode	Bit Map	See description	R/W
0x0002	Fault Status 1	User status errors	Bit Map	See description	R
0x0003	Fault Status 2	Internal status errors	Bit Map	See description	R
0x0004	Model No.	Observer i model number	Numeric Value	TBD	R
0x0005	Software Rev Hi	Embedded software major revision	ASCII chars	Alphanumeric	R
0x0006	SPL	Sound pressure level (dB)	Numeric Value	~ 45 – 110 dB	R
0x0007	Peak Sound	Peak sound level (dB)	Numeric Value	TBD	R
0x0008	Temperature	Unit temperature in 0.1°C	Numeric Value	-40°C – +75°C expressed in 0.1 °C	R
0x0009	Display Chars Hi	Display MSD and MID1	ASCII chars	See description	R
0x000A	Display Chars Lo	Display MID2 and LSD	ASCII chars	See description	R
0x000B	Serial No. Hi	Unit serial number - high word	ASCII chars	See description	R
0x000C	Serial No. Lo	Unit serial number - low word	ASCII chars	See description	R
0x000D	Trigger Level	Set/view alarm trigger level	Numeric Value	See description	R/W
0x000E	Alarm Delay	Set/view alarm delay time	Numeric Value	See description	R/W
0x000F	CH1 Address	Set/view channel 1 address	Numeric Value	1 – 247	R/W
0x0010	CH1 Baud Rate	Set/view channel 1 baud rate (2.4, 4.8, 9.6, 19.2 kbps)	Code	0, 1, 2, 3	R/W
0x0011	CH1 Format	Set/view channel 1 data format (8N1, 8E1, 8O1, 8N2)	Code	0, 1, 2, 3	R/W
0x0012	CH2 Address	Set/view channel 2 address	Numeric Value	1 – 247	R/W
0x0013	CH2 Baud Rate	Set/view channel 2 baud rate (2.4, 4.8, 9.6, 19.2 kbps)	Code	0, 1, 2, 3	R/W
0x0014	CH2 Format	Set/view channel 2 data format (8N1, 8E1, 8O1, 8N2)	Code	0, 1, 2, 3	R/W
0x0015	Software Rev Hi	Embedded software minor revision	ASCII chars	Alphanumeric	R
0x0016	Reset Alarms	Set to clear all alarms	Numeric Value	0	R/W
0x0017	Cal Sub Mode	Shows the stages of Calibration	Numeric Value	See description	R
0x0018	Acoustic Test	Initiates the acoustic test routine	Numeric Value	0 – 1	R/W
0x0019	HazardWatch	Enables HazardWatch flag	Numeric Value	0 -1	R/W
0x001A	Relay State	Indicates the state of relays	Bit Map	See description	R
0x001B	Alarm Latch	Set/clear alarm latching state	Numeric Value	0 or 1	R/W
0x001C	Relay Energize	Set/clear relay energize state	Numeric Value	0 or 1	R/W
0x001D	HART Enable	Enable HART on channel 2	Numeric Value	0 or 1	R/W
0x001E	HART Test	Test HART communication	Numeric Value	0, 1, 2	R/W
0x001F	Cal Abort	Abort calibration	Numeric Value	1	R/W
0x0020	Ch1 UART Receive Errors	Total number of UART channel 1 receive errors	Numeric Value	0 – 65535	R
0x0021	Ch1 Bus Activity Rate	Serial Ch1 bus activity rate	Numeric Value	0 – 100	R
0x0022	Ch1 Function Code Errors	Number of Modbus channel 1 function code errors	Numeric Value	0 – 65535	R
0x0023	Ch1 Starting Address Errors	Number of Modbus channel 1 starting address errors	Numeric Value	0 – 65535	R
0x0024	Ch1 Register Errors	Number of Modbus channel 1 register errors	Numeric Value	0 – 65535	R
0x0025	Ch1 CRC Hi Errors	Number of Modbus channel 1 Hi	Numeric Value	0 – 65535	R

## 6 Modbus Digital Interface

		CRC errors		
0x0026	Ch1 CRC Lo Errors	Number of Modbus channel 1 Lo CRC errors	Numeric Value 0 – 65535	R
0x0027	Ch1 Parity Errors	Number of serial channel 1 parity errors	Numeric Value 0 – 65535	R
0x0028	Ch1 Overrun Errors	Number of serial channel 1 overrun errors	Numeric Value 0 – 65535	R
0x0029	Ch1 Framing Errors	Number of serial channel 1 framing errors	Numeric Value 0 – 65535	R
0x002A	Ch1 Modbus Receive Errors	Total number of Modbus channel 1 receive errors	Numeric Value 0 – 65535	R
0x002B	Factory Defaults	Set factory defaults for alarm and relay settings	Numeric Value 1	R/W
0x002C	Clear Ch1 UART Errors	Clears UART total receive error counters	Numeric Value 0	R/W
0x002D	Clear Ch1 Modbus Errors	Clears Modbus total receive error counters	Numeric Value 0	R/W
0x002E	HART Min AO	Sets minimum analog output current for HART protocol	Numeric Value 0 – 3.5 mA 1 – 1.25 mA	R/W
0x002F	HART Present Flag	Indicates presence of HART hardware	Numeric Value 0 – not present 1 – present	R
<b>Event Logging Registers</b>				
0x0030	Run Time Hi	Read/Set run-time seconds High word	Numeric Value 0 – 65535	R/W
0x0031	Run Time Lo	Read/Set run-time seconds Low word	Numeric Value 0 – 65535	R/W
0x0032	Real Time Clock Year, Month	Read/Set year and month of Real-Time Clock (RTC)	Numeric Value 1 – 99 year, 1 – 12 month	R/W
0x0033	Real Time Clock Day, Hour	Read/Set day and hour of RTC	Numeric Value 1 – 31 day, 0 – 23 hour	R/W
0x0034	Real Time Clock Minute, Second	Read/Set minutes and seconds of RTC	Numeric Value 0 – 59 minutes 0 – 59 seconds	R/W
0x0035	Power Cycled Flag	Time Reset After power Cycled	Numeric Value 0 = Time not Reset, 1 = Time Reset	R
0x0036	Event Index	Index of Logged Events	Numeric Value 0 – 9	R/W
<b>Reserved</b>				
0x0037	Reserved	Reserved	Numeric Value 0	R
0x0038	Reserved	Reserved	Numeric Value 0	R
0x0039	Reserved	Reserved	Numeric Value 0	R
0x003A	Reserved	Reserved	Numeric Value 0	R
0x003B	Reserved	Reserved	Numeric Value 0	R
0x003C	Reserved	Reserved	Numeric Value 0	R
0x003D	Reserved	Reserved	Numeric Value 0	R
0x003E	Reserved	Reserved	Numeric Value 0	R
<b>Alarm Event Log</b>				
0x003F	Run Time Hi	Running Time Hi for Alarm Event log entries	Numeric Value 0 - 65535	R
0x0040	Run Time Lo	Running Time Low for Alarm Event log entries	Numeric Value 0 - 65535	R
0x0041	Clock Time Hi	Hi byte = year, Lo byte month: Alarm clock time	Numeric Value 1 – 99 year, 1 – 12 month	R
0x0042	Clock Time Mid	Hi byte = Day, Lo byte Hour: Alarm clock time	Numeric Value 1 – 31 day, 0 – 23 hour	R

0x0043	Clock Time Low	Hi byte = Minute, Lo byte second: Alarm clock time	Numeric Value	0 – 59 minutes 0 – 59 seconds	R
0x0044	Alarm Detection Type & Peak dB	Alarm Detection Type and Peak dB during Alarm	Numeric Value	0-65535	R
0x0045	Reserved	Reserved	Numeric Value	0	R
0x0046	Alarm Count	Total Alarm Event Count	Numeric Value	0 – 65535	R
<b>Fault Event Log</b>					
0x0047	Run Time Hi	Running Time Hi for Fault Event log entries	Numeric Value	0 - 65535	R
0x0048	Run Time Lo	Running Time Low for Fault Event log entries	Numeric Value	0 - 65535	R
0x0049	Clock Time Hi	Hi byte = year, Lo byte month: Fault clock time	Numeric Value	1 –99 year, 1– 12 month	R
0x004A	Clock Time Mid	Hi byte = Day, Lo byte Hour: Fault clock time	Numeric Value	1 – 31 day, 0 – 23 hour	R
0x004B	Clock Time Low	Hi byte = Minute, Lo byte second: Fault clock time	Numeric Value	0 – 59 minutes 0 – 59 seconds	R
0x004C	Fault Cause	Observer i fault code	Numeric Value	See description	R
0x004D	Reserved	Reserved	Numeric Value	0	R
0x004E	Fault Count	Total Fault Event Count	Numeric Value	0 – 65535	R
<b>Maintenance Event Log</b>					
0x004F	Run Time Hi	Running Time Hi for Maintenance Event log entries	Numeric Value	0 - 65535	R
0x0050	Run Time Lo	Running Time Low for Maintenance Event log entries	Numeric Value	0 - 65535	R
0x0051	Clock Time Hi	Hi byte = year, Lo byte month: Maintenance clock time	Numeric Value	1 –99 year, 1– 12 month	R
0x0052	Clock Time Mid	Hi byte = Day, Lo byte Hour: Maintenance clock time	Numeric Value	1 – 31 day, 0 – 23 hour	R
0x0053	Clock Time Low	Hi byte = Minute, Lo byte second: Maintenance clock time	Numeric Value	0 – 59 minutes 0 – 59 seconds	R
0x0054	Maint. Code	Observer i maintenance code	Numeric Value	See description	R
0x0055	Reserved	Reserved	Numeric Value	0	R
0x0056	Maint. Count	Total maintenance event count	Numeric Value	0 – 65535	R
<b>Calibration Event Log</b>					
0x0057	Run Time Hi	Running Time Hi for calibration event log entries	Numeric Value	0 - 65535	R
0x0058	Run Time Lo	Running Time Low for calibration event log entries	Numeric Value	0 - 65535	R
0x0059	Clock Time Hi	Hi byte = year, Lo byte month: calibration clock time	Numeric Value	1 –99 year, 1– 12 month	R
0x005A	Clock Time Mid	Hi byte = Day, Lo byte Hour: calibration clock time	Numeric Value	1 – 31 day 0 – 23 hour	R
0x005B	Clock Time Low	Hi byte = Minute, Lo byte second: calibration clock time	Numeric Value	0 – 59 minutes 0 – 59 seconds	R
0x005C	Cal Code	Observer i calibration code	Numeric Value	See description	R
0x005D	Reserved	Reserved	Numeric Value	0	R
0x005E	Cal Count	Total calibration event count	Numeric Value	0 – 65535	R
0x005F	Clear All Events	Set to clear all event logs	Numeric Value	0	
<b>Miscellaneous User Registers</b>					
0x0060 – 0x006F	User Info	User information registers	Numeric Value	0 – 65535	

## 6 Modbus Digital Interface

0x0070	Ch2 UART Receive Errors	Total number of UART channel 2 receive errors	Numeric Value 0 – 65535	R
0x0071	Ch2 Bus Activity Rate	Serial channel 2 bus activity rate	Numeric Value 0 – 100	R
0x0072	Ch2 Function Code Errors	Number of Modbus channel 2 function code errors	Numeric Value 0 – 65535	R
0x0073	Ch2 Starting Address Errors	Number of Modbus channel 2 starting address errors	Numeric Value 0 – 65535	R
0x0074	Ch2 Register Errors	Number of Modbus channel 2 register errors	Numeric Value 0 – 65535	R
0x0075	Ch2 CRC Hi Errors	Number of Modbus channel 2 Hi CRC errors	Numeric Value 0 – 65535	R
0x0076	Ch2 CRC Lo Errors	Number of Modbus channel 2 Lo CRC errors	Numeric Value 0 – 65535	R
0x0077	Ch2 Parity Errors	Number of serial channel 2 parity errors	Numeric Value 0 – 65535	R
0x0078	Ch2 Overrun Errors	Number of serial channel 2 overrun errors	Numeric Value 0 – 65535	R
0x0079	Ch2 Framing Errors	Number of serial channel 2 framing errors	Numeric Value 0 – 65535	R
0x007A	Ch2 Modbus Receive Errors	Total number of Modbus channel 2 receive errors	Numeric Value 0 – 65535	R
0x007B	Reserved	N/A	Numeric Value N/A	R
0x007C	Clear Ch1 UART Errors	Clears UART total receive error counters	Numeric Value 0	R/W
0x007D	Clear Ch1 Modbus Errors	Clears Modbus total receive error counters	Numeric Value 0	R/W
0x007E	Reserved	N/A	Numeric Value N/A	R
0x00D9	Detection Mode	Unit Detection Mode	Numeric Value 0 or 1	R/W
0x00DA	Enhanced Analog Output	Enhanced Analog Output Mode	Numeric Value 1, 2, 3	R/W
0x00E2	Set Cut-off Frequency	Set Cut-off Frequency	Numeric Value 0 or 1	R/W

### 6.7 Observer i Command Register Details

#### 6.7.1 Analog (00H)

A read returns a value which is proportional to the 0-20 mA output current. The current is based on a 16-bit value. The number represents the current in microamps (µA).

#### 6.7.2 Mode (01H)

A read returns the Observer i operation status mode.

Table 13 Operation Status Mode

Bit Position	15	14	13	12	11	10	9	8
Fault Description	Not Used	Not Used	Not Used	Not Used	Not Used	Alarm Mode	Piezo Cal	Cal Pending
Hex Value	0x8000	0x4000	0x2000	0x1000	0x0800	0x0400	0x0200	0x0100
Decimal Value	32768	16384	8192	4096	2048	1024	512	256
Bit Position	7	5	4	3	2	1	0	
Fault Description	Alarm Test	Setup Mode	Fault Mode	Cal Mode	Acoustic Test	Run Mode	Startup Mode	
Hex Value	0x0080	0x0020	0x0010	0x0008	0x0004	0x0002	0x0001	
Decimal Value	128	32	16	8	4	2	1	

**READ:**

A read request to this register returns the present Observer i operating mode represented by the enabled bit. Descriptions of the modes are provided below:

- **Startup:** Observer i initialization during the power-up cycle.
- **Run:** Normal operating mode of the instrument.
- **Acoustic Test:** This bit is set anytime an acoustic test is taking place. The request of the acoustic test can be from the magnet, a timed acoustic test, a HART request or a Modbus request.
- **Calibrate:** This bit is set anytime a calibration is taking place. The request of the calibration test can be from the magnet, a timed acoustic test, a HART request or a Modbus request.
- **Fault:** This bit is set any time the Observer i has a fault.
- **Setup:** Indicates the user has activated a magnet and is in setup mode.
- **Alarm Test:** This indicates someone has activated the alarm test. This can be done via a remote switch, HART, or Modbus.
- **Calibration Pending:** The Cal pending bit is used to indicate an intermediate state.
- **Piezo Calibration:** This bit is not used in normal operation. It is used only when the piezo or microphone is replaced. It is set when the technician calibrates the piezo.
- **Alarm:** This bit is used when the Observer i detects dB greater than the trigger level. If the Observer i is latched it will stay in alarm mode until the reset relay is activated.
- **Show Rev:** This bit is set during the time someone has activated the show rev by using an UP and DOWN magnet.

**WRITE:**

A write to the mode register (01) with the proper bit set will cause the Observer i to change modes. Not all modes can be activated in this manner. If an improper bit or the action is not allowed at this time an exception will be returned.

- **Alarm Test:** The alarm bit is a toggle. The first write sets the mode the second write clears the mode.
- **Acoustic Test:** This mode will perform a non-continuous acoustic test. The acoustic test will not be allowed if a gas leak is above the trigger level, instead an exception will be returned. The display will show a "COM".
- **Calibrate:** This will put the Observer i into calibration mode. It will be ready for the 1701 to be activated. Calibration will not be allowed if a gas leak is above the trigger level instead an exception will be returned.
- **Operational Mode:** Writing an operational mode bit will abort any of the above modes. It will not go back to operational mode until it is safe.

**6.7.3 Primary Fault Status/Error 1 (02H)**

A read returns the errors that are occurring, which are indicated by bit position. This status word is used as the primary status error word. This is the only one that needs to be read to know if there are any errors.

## 6 Modbus Digital Interface

Table 14 Fault Status/Error 1

Bit Position	15	14	13	12	11	10	9	8
Fault Description	Error Lower level	Not Used	BELOW ATREF	Not Used	Event Memory	Hart Memory	User Memory	Critical Memory
Hex Value	0x8000	0x4000	0x2000	0x1000	0x0800	0x0400	0x0200	0x0100
Decimal Value	32768	16384	8192	4096	2048	1024	512	256
Display Fault Code	N/A				EEVT	EHRT	EUSR	ECRT

Bit Position	7	6	5	4	3	2	1	0
Fault Description	Internal Voltage	Magnet Switch	Reset Switch	Alarm Switch	Not Used	Acoustic Test	Not Used	24V Low Line
Hex Value	0x0080	0x0040	0x0020	0x0010	0x0008	0x0004	0x0002	0x0001
Decimal Value	128	64	32	16	8	4	2	1
Display Fault Code	EINV	EMAG	ERSW	EASW	ERAC		ERV_	

See the ERROR OUTPUT Section for explanation of errors. Bit 13 is special for Modbus and HART. When the Observer i is in acoustic test, this bit is set to “1” if the acoustic sound level is above the desired level, and to “0” – if it is below the desired level. This allows the system to quickly know if there is an acoustic test problem.

Bit 15 is set to “1” if any of the lower level faults are present. The system can now drill down and find the root cause. Normally, this is not required at the system level, but only at a test station.

### 6.7.4 Fault Status/Error 2 (03H)

A read-only accessible register contains the bit map for any internal error that is present. The following table shows the faults that are represented by each bit in the register.

Table 15 Fault Status/Error 2

Bit Position	15	14	13	12	11	10	9	8
Fault Description	Word	Event RAM	HART RAM	System RAM	Critical RAM	Event Flash	HART Flash	System Flash
Hex Value	0x8000	0x4000	0x2000	0x1000	0x0800	0x0400	0x0200	0x0100
Decimal Value	32768	16384	8192	4096	2048	1024	512	256
Display Fault Code	N/A	N/A	N/A	N/A	N/A	N/A	N/A	N/A

Bit Position	7	6	5	4	3	2	1	0
Fault Description	Critical Flash	CPU RAM	CPU Flash	-5V Ref.	+5V Ref.	-12V Ref.	+12V Ref.	Current Ref.
Hex Value	0x0080	0x0040	0x0020	0x0010	0x0008	0x0004	0x0002	0x0001
Decimal Value	128	64	32	16	8	4	2	1
Display Fault Code	N/A	N/A	N/A	N/A	N/A	N/A	N/A	N/A

### 6.7.5 Model Type (04H)

A read returns the Decimal Value indicating the model number. The Observer i model number is “6000”. Notice: If a newer Observer i is designed to replace the Observer i the model number will be different.

### 6.7.6 Software Revision Major (05H)

A read-only accessible register contains the major (user) alphanumeric revision value of the Observer i embedded software expressed in 2 ASCII characters (REV “A” appears as a blank and the letter A).

**6.7.7 dB Level (06H)**

A read-only accessible register contains the value of the measured SPL expressed in decibels.

**6.7.8 Peak Sound (07H)**

A read-only accessible register contains the acoustic test peak sound level expressed in decibels.

**6.7.9 Unit Temperature (08H)**

A read-only accessible register contains the value of internal unit temperature expressed in 0.1°C units. These functions are indicated on the Low Data Byte and the High Data Byte is not used.

**6.7.10 Modbus Display (09H, 0AH)**

09H: A read-only accessible register contains the upper two ASCII characters shown on the Observer i display.

0AH: A read-only accessible register contains the lower two ASCII characters shown on the Observer i display.

**6.7.11 Serial Number (0BH, 0CH)**

The serial number is a 32-bit word but the value is only 23 bits long. The upper bits are always zero. This is done to keep the same serial number as the HART serial number. Address 0x16 contains the lower part of the number and address 0x15 contains the upper part.

**6.7.12 Trigger Level (0DH)**

This is a read/write register. A read will return the present trigger level. Since the trigger level can only be incremented by 5, only certain values are allowed.

**EXCEPTION** - If an illegal data value is entered (must be one of the numbers in the table), then the Exception Code 03 (Illegal Data Value) is returned.

<b>Valid Trigger levels</b>	<b>44</b>	<b>49</b>	<b>54</b>	<b>59</b>	<b>64</b>	<b>69</b>	<b>74</b>	<b>79</b>	<b>84</b>	<b>89</b>	<b>94</b>	<b>99</b>	<b>dB</b>
-----------------------------	-----------	-----------	-----------	-----------	-----------	-----------	-----------	-----------	-----------	-----------	-----------	-----------	-----------

**6.7.13 Trigger Delay (0EH)**

This is a read/write register. A read will return the present time delay. The time delay has a range of 0 to 240 seconds. A one represents 1 second.

**EXCEPTION** - If an illegal data value is entered (must be between 0-240), then the Exception Code 03 (Illegal Data Value) is returned

**6.7.14 Comm 1 Address (0FH)**

A read returns the Comm 1 address of the Observer i. A write changes the address to the requested address. The range of the address is 1 to 247 (01 to F7 Hex). After the address has been changed to the slave unit, the Modbus communications will cease because the address has changed; therefore, the master will have to change its query address to the slave's new address in order to restart the communications.

**EXCEPTION** - If an illegal data value is entered (must be between 1-0x00F7), then the Exception Code 03 (Illegal Data Value) is returned.

**NOTE:** The default Address is 1.

### 6.7.15 Comm 1 Baud Rate (10H)

A read returns the Comm 1 baud rate of the Observer i. A write changes the baud rate to the requested baud rate. After the baud rate has been changed to the addressed unit, the Modbus communications will cease because the baud rate has changed; therefore, the master will have to change its baud rate to the slave's new baud rate in order to restart the communications.

Table 16 Comm 1 Baud Rate

Baud Rate	Low Data Byte	Access
57.6K	06	Read/Write
38.4K	05	Read/Write
19.2K	04	Read/Write
9600	03	Read/Write
4800	02	Read/Write
2400	01	Read/Write

This function is indicated on the Low Data Byte (the High Data Byte is not used).

**EXCEPTION** - If an illegal data value is entered which is not listed above, then the Exception Code 03 (Illegal Data Value) is returned.

**NOTE:** The default baud rate is 19200.

### 6.7.16 Comm 1 Data Format (11H)

A read returns the Comm 1 data format of the Observer i. A write changes the data format to the requested data format. After the data format has been changed to the addressed unit, the Modbus communications may cease or start producing Comm errors because the data format has changed; therefore, the master will have to change its data format to the slave's new data format in order to restart or provide proper communications.

Table 17 Comm 1 Data Format

Data	Parity	Stop	Format	Low Data Byte	Access
8	None	1	8-N-1	00	Read/Write
8	Even	1	8-E-1	01	Read/Write
8	Odd	1	8-O-1	02	Read/Write
8	None	2	8-N-2	03	Read/Write

This function is indicated on the Low Data Byte and the High Data Byte is not used.

**EXCEPTION** - If an illegal data value is entered which is not listed above, then the Exception Code 03 (Illegal Data Value) is returned.

**NOTE:** The default Data Format is 8-N-1.

### 6.7.17 Comm 2 Address (12H)

A read returns the Comm 2 address of the Observer i. A write changes the address to the requested address. The range of the address is 1 to 247 (01 to F7 Hex). After the address has been changed to the slave unit, the Modbus communications will cease because the address has changed; therefore, the master will have to change its query address to the slave's new address in order to restart the communications.

**EXCEPTION** - If an illegal data value is entered (must be between 1-0x00F7), then the Exception Code 03 (Illegal Data Value) is returned.

**NOTE:** The default address is 2.

### 6.7.18 Comm 2 Baud Rate (13H)

A read returns the Comm 2 baud rate of the Observer i. A write changes the baud rate to the requested baud rate. After the baud rate has been changed to the addressed unit, the Modbus communications will cease because the baud rate has changed; therefore, the master will have to change its baud rate to the slave's new baud rate in order to restart the communications.

Table 18 Comm 2 Baud Rate

Baud Rate	Low Data Byte	Access
57.6K	06	Read/Write
38.4K	05	Read/Write
19.2K	04	Read/Write
9600	03	Read/Write
4800	02	Read/Write
2400	01	Read/Write

This function is indicated on the Low Data Byte (the High Data Byte is not used).

**EXCEPTION** - If an illegal data value is entered which is not listed above, then the Exception Code 03 (Illegal Data Value) is returned.

**NOTE:** The default Baud Rate is 19200.

### 6.7.19 Comm 2 Data Format (14H)

A read returns the Comm 2 data format of the Observer i. A write changes the data format to the requested data format. After the data format has been changed to the addressed unit, the Modbus communications may cease or start producing communication errors because the data format has changed; therefore, the master will have to change its data format to the slave's new data format in order to restart or provide proper communications.

Table 19 Comm 2 Data Format

Data	Parity	Stop	Format	Low Data Byte	Access
8	None	1	8-N-1	00	Read/Write
8	Even	1	8-E-1	01	Read/Write
8	Odd	1	8-O-1	02	Read/Write
8	None	2	8-N-2	03	Read/Write

This function is indicated on the Low Data Byte and the High Data Byte is not used.

**EXCEPTION** - If an illegal data value is entered which is not listed above, then the Exception Code 03 (Illegal Data Value) is returned.

**NOTE:** The default Data Format is 8-N-1.

### 6.7.20 Software Rev Minor (15H)

A read-only accessible register contains minor (internal) numeric revision value of the Observer i embedded software expressed in 2 ASCII characters.

### 6.7.21 Reset Alarm (16H)

Writing a "1" to this register will reset the alarm relay.

**EXCEPTIONS** - If an illegal data value is entered (must be between 0-1), then the Exception Code 03 (Illegal Data Value) is returned.

If the Observer i hears a gas leak greater than the trigger when the command is received a Code 06 (device busy) exception will be returned.

### 6.7.22 Sub Mode (17H)

This is a read only register. It is used to tell the control system the states of calibrate mode.

Table 20 Calibrate Sub Mode

Calibrate Sub Mode	Number returned
Apply 1701	0x0001
Calibration in progress	0x0002
Calibration adjustment	0x0004
Calibrate OK	0x0008
Calibrate error	0x0010

### 6.7.23 Acoustic Test (18H)

This is a write only register. Writing a “1” to this register will activate an acoustic test. This is a one cycle test. During the test the display will show “COM”. The current will go to 3.0 mA.

**EXCEPTIONS** - If an illegal data value is entered (must be between 0-1), then the Exception Code 03 (Illegal Data Value) is returned.

If the Observer i hears a gas leak greater than the trigger when the command is received a Code 06 (device busy) exception will be returned.

### 6.7.24 HazardWatch (19H)

HazardWatch indicates when a successful calibration takes place. In HazardWatch mode the current goes to 3.2 mA for 5 seconds then to 4.0 mA. An aborted calibration would go straight to 4.0 mA.

This is a read/write only register. Reading returns the state of the HazardWatch. (ON/OFF). Writing a 1 will turn on HazardWatch, a “0” will disable.

**EXCEPTIONS** - If an illegal data value is entered (must be between 0-1), then the Exception Code 03 (Illegal Data Value) is returned.

### 6.7.25 Relay State (1AH)

The relay state register is read only. The bit position shows which relay is on.

Table 21 Relay State

Function	Hex Value
Alarm Relay Energized	0x0001
Fault Relay Energized	0x0002
1701 LED Energized	0x0004

### 6.7.26 Alarm Latch (1BH)

The alarm latch register is read/write. A read returns if the alarm latch is enabled or not. A write enables or disables latching. One is latch zero is non – latched.

**EXCEPTIONS** - If an illegal data value is entered (must be between 0-1), then the Exception Code 03 (Illegal Data Value) is returned. If the Observer i hears a gas leak greater than the trigger when the command is received a Code 06 (device busy) exception will be returned.

### 6.7.27 Relay Energize (1CH)

The relay energized register is read/write. A read returns if the alarm relay is normally energized or not. One is energized a zero is de-energized.

**EXCEPTIONS** - If an illegal data value is entered (must be between 0-1), then the Exception Code 03 (Illegal Data Value) is returned. If the Observer i hears a gas leak greater than the trigger when the command is received a Code 06 (device busy) exception will be returned.

#### 6.7.28 HART Enable (1DH)

The HART enable register read/write. This command enables or disables HART. A "0" is HART disabled. A "1" is HART Enabled. This is an option that must be ordered.

**EXCEPTIONS** - If an illegal data value is entered (must be between 0-1), or if HART is not installed then the Exception Code 03 (Illegal Data Value) is returned.

#### 6.7.29 HART Test (1EH)

This command is used to test the HART output. It produces constant zeros or constant ones on the HART output. This is only available if the HART option was purchased.

**EXCEPTIONS** - If an illegal data value is entered (must be between 0-1), or if HART is not installed then the Exception Code 03 (Illegal Data Value) is returned.

*Table 22 HART Codes*

Code	Results
0	Normal
1	Constant ones
2	Constant zeros

#### 6.7.30 Cal Abort (1FH)

Writing to the calibrate abort register will abort calibration and return the Observer i to normal.

#### 6.7.31 Comm 1 Total Illegal number of registers Errors (20H)

A read indicates the total illegal number of registers errors on the Comm 1 Modbus. The maximum count is 65535 and then the counter rolls over to zero and begins counting again.

#### 6.7.32 Comm 1 Bus Activity Rate % (21H)

A read indicates the Comm 1 Bus Activity Rate in percent of this Slave's addressed node versus other addressed nodes. Range of this value is in hex (0-64), which translates to decimal (0-100%).

#### 6.7.33 Comm 1 Function Code Errors (22H)

A read indicates the number of Comm Function Code Errors that occurred in the slave device. The maximum count is 65535 and then the counter rolls over to zero and begins counting again.

#### 6.7.34 Comm 1 Starting Address Errors (23H)

A read indicates the number of Comm 1 Starting Address Errors that occurred in the slave device. The maximum count is 65535 and then the counter rolls over to zero and begins counting again.

#### 6.7.35 Comm 1 Total Receive Errors (24H)

A read indicates the total Modbus Comm 1 Only Receive Errors that occurred in the slave device. These are address, function, etc. type of errors. The maximum count is 65535 and then the counter rolls over to zero and begins counting again.

### 6.7.36 RXD CRC Errors (25h)

A read indicates the number of RXD CRC Errors that occurred in the slave device. The maximum count is 65535 and then the counter rolls over to zero and begins counting again.

### 6.7.37 RXD CRC Errors (26h)

Same as (25h).

### 6.7.38 Comm 1 Parity Errors (27H)

A read indicates the number of Comm 1 Only Parity Errors that occurred in the slave device. The maximum count is 65535 and then the counter rolls over to zero and begins counting again.

### 6.7.39 Comm 1 Overrun Errors (28H)

A read indicates the number of Comm 1 Overrun Errors that occurred in the slave device. The maximum count is 65535 and then the counter rolls over to zero and begins counting again.

**NOTE:** An overrun error occurs when the next received byte of data tries to overwrite an existing received data byte, which has not been processed. Therefore, the next received byte of data is lost. This can be controlled by implementing the proper DCS or PLC Error Handling Timing Setting (ex. Reply Timeout Setting, Delay Time, and Number of Retries) and proper Baud Rate Setting.

### 6.7.40 Comm 1 Framing Errors (29H)

A read indicates the number of Comm 1 Framing Errors that occurred in the slave device. The maximum count is 65535 and then the counter rolls over to zero and begins counting again.

### 6.7.41 Comm 1 Total UART Receive Errors (2AH)

A read indicates the total Modbus Comm 1 Receive Errors that occurred in the slave device. The maximum count is 65535 and then the counter rolls over to zero and begins counting again. The total errors are an accumulation of the individual communication errors such as Overrun, CRC, Parity and Framing errors.

### 6.7.42 Factory Default (2BH)

Writing 1 to this register will load the factory default values for alarm, Modbus and HART settings.

The factory default register is read/write. This command can set all the settings to factory default by writing 1. A read returns "1" if the factory setting is set default or returns "0" if the settings are different than the factory default.

### 6.7.43 Comm 1 Clear error (2CH)

Writing 1 to this register clears all UART receive communication (framing, overrun, parity) error counters on serial channel 1.

### 6.7.44 Clear Stats 1(2D)

Writing 1 to this register clears all Modbus (function, starting register address, number of registers, CRC) error counters on serial channel 1.

### 6.7.45 HART Current (2E)

Normally in HART mode the low current does not go below 3.5 mA. In order for the current to distinguish between Fault and offline there is a HART setting that allows the current to go as low as 1.25 mA. A read returns "1" or "0".

*Table 23 HART Current Levels*

Condition	Normal HART Current	HART Expanded Scale	Units
Run	4 to 20	4 ,8, 12,16, 20	mA
Acoustic Fault	1*	1.25*	mA
Fault	3.5	1.25	mA

**EXCEPTIONS** - If an illegal data value is entered (must be between 0-1), then the Exception Code 03 (Illegal Data Value) is returned

#### 6.7.46 HART Present (2F)

HART present is a read only register. A "1" indicates HART is installed. A "0" means HART is not installed.

**NOTE:** HART can be installed and not enabled but it cannot be enabled if not installed.

### 6.8 Event Logging (30H – 5FH)

The Observer i logs Alarm, Fault, Calibration, and Maintenance events. Each event group will store a total of 10 events in a first-in-first-out manner. An identifying number and time stamp is also stored for each event.

#### 6.8.1 Faults

- Whenever the fault word changes the time will be recorded (See Primary fault)
- The time of the fault will be saved
- When the fault is removed, it is not saved and the counter is not incremented
- A fault event is logged for every 30 seconds recorded

#### 6.8.2 Alarm

The time the gas level reaches the Alarm level is recorded. Each time this happens a counter is incremented. The end of the event is when the sound level goes 5% below the alarm level.

#### 6.8.3 Calibration

##### Microphone Calibration

When a calibration is finished a counter is incremented for each calibration attempt. The identifying number stored depends on the ending condition.

*Table 24 Calibration Counter*

Condition	Identifying Number
Calibrate OK	4
Calibrate Adjust	5
Calibrate Error	6

#### 6.8.4 Maintenance

There are a total of 10 maintenance events stored. The number stored with the time stamp will indicate the source of the maintenance event.

##### Piezo

When a Piezo calibration (seven up: seven times on the UP) is saved a maintenance event will occur. The value stored will be 4. A factory piezo calibration will have the number 9.

##### Alarm Test

When an alarm test is initiated, a maintenance event will occur. The event code will be 6. Running Time in Seconds Hi Word (0x30)

This sets/reads hi word of device running time in seconds. This value must be read/written prior to running time low byte (register 0x00B2).

### Running Time in Seconds Lo Word (0x31)

This sets/reads hi word of device running time in seconds. This value must be read/written after running time hi byte (register 0x00B1). See the Real Time Clock Time Format below:

Table 25 Real Time Clock Time Format

Item Number	Description
1	Hi Byte =Year, Low Byte = Month
2	Hi Byte = Day, Low Byte = Hour
3	Hi Byte = Minute, Low Byte = Second

### Real-time Clock Year, Month (0x32)

This is used to read/write the real time clock. The high byte will be the year minus 2000. The low byte will be a value from 1 to 12. To get or set real time, read or write year/month (0x00B3) first, then day/hour (0x00B4), then min/sec (0x00B5).

### Real-time Clock Day, Hour (0x33)

This is used to read/write the real time clock. The high byte will be the day of the month from 1 to 31. The low byte will be the hour from 0 to 23. To get or set real time, read or write year/month (0x00B3) first, then day/hour (0x00B4), then min/sec (0x00B5).

### Real-time Clock Minute, Second (0x34)

This is used to read/write the real time clock. The high byte will be the minute from 0 to 59 and the low byte will be the seconds from 0 to 59. To get or set real time, read or write year/month (0x00B3) first, then day/hour (0x00B4), then min/sec (0x00B5).

### Power Cycle Flag (0x35)

This reads whether the time of day clock has been reset after power has been re-cycled to the unit. If the time has been reset, this flag will be = 0; otherwise the flag will = 1.

### Event Index (0x36)

This is used to indicate which of the stored events the user would like to read. There are 5 event logs: Warning events, Alarm events, Fault events, Calibration events and Maintenance events. Each of these event logs consist of 10 of their most recent occurrences. The user is able to read the logs of each of these by setting this event index followed by a reading of the desired event log. The event index is a number from 0 to 9. Zero refers to the most recent event and 9 refers to the least recent event stored in the log. For example to read time of the most recent Warning event in the Warning event log, set this register to 0 and then read registers 0xB8 and 0xB9 (for the running time in seconds) or read registers 0xBA, 0xBB, and 0xBC (for the clock time).

### Reserved (0x37 - 3E )

### Alarm Running Time in Seconds, Hi Word (0x3F)

This register reads the high word of the running time in seconds when the alarm event occurred. This time is in seconds since January 1, 2000.

### Alarm Running Time in Seconds, Low Word (0x40)

This register reads the low word of the running time in seconds when the alarm event occurred. This time is in seconds since January 1, 2000.

### Alarm Clock Time: Year, Month (0x41) Alarm Structure Hi

These registers are described in the Event Logging Registry Table as item number 1.

### Alarm Clock Time: Day, Hour (0x42) Alarm Structure Mid

These registers are described in the Event Logging Registry Table as item number 2.

**Alarm Clock Time: Minute, Seconds (0x43) Alarm Structure Low**

These registers are described in the Event Logging Registry Table as item number 3.

**Alarm Detection Type and Peak dB during alarm (0x44)**

The High byte indicates the Detection type at alarm and the low byte is a peak dB during the alarm.

Alarm Event Detection	Value in Hex
By Classic Mode	0x0000
By Enhanced Mode	0x0001

**Spare (0x45)**

Spare register.

**Total Alarm Event Counter (0x46)**

This reads the total number of alarm events that have been stored in the unit.

**Fault Running Time in Seconds, Hi Word (0x47)**

This register reads the high word of the running time in seconds when the fault event occurred. This time is in seconds since January 1, 2000.

**Fault Running Time in Seconds, Low Word (0x48)**

This register reads the low word of the running time in seconds when the fault event occurred. This time is in seconds since January 1, 2000.

**Fault Clock Time: Year, Month (0x49) Fault Structure Hi**

These registers are described in the Event Logging Registry Table as item number 1.

**Fault Clock Time: Day, Hour (0x4A) Fault Structure Mid**

These registers are described in the Event Logging Registry Table as item number 2.

**Fault Clock Time: Minute, Seconds (0x4B) Fault Structure Low**

These registers are described in the Event Logging Registry Table as item number 3.

**Fault Code (0x4C) Fault Cause**

This register is described in the Event Logging Registry Table.

**Spare (0x4D)**

Spare register.

**Total Fault Event Counter (0x4E)**

This reads the total number of fault events that have been stored in the unit.

**Maintenance Running Time in Seconds, Hi Word (0x4F)**

This register reads the high word of the running time in seconds when the gas check event occurred. This time is in seconds since January 1, 2000.

**Maintenance Running Time in Seconds, Low Word (0x50)**

This register reads the low word of the running time in seconds when the gas check event occurred. This time is in seconds since January 1, 2000.

**Maintenance Clock Time: Year, Month (0x51)**

These registers are described in the Event Logging Registry Table as item number 1.

**Maintenance Clock Time: Day, Hour (0x52)**

These registers are described in the Event Logging Registry Table as item number 2.

### **Maintenance Clock Time: Minute, Seconds (0x53)**

These registers are described in the Event Logging Registry Table as item number 3.

### **Maintenance Cause (0x54)**

There are three maintenance event types:

- User started acoustic test: code = 9
- Alarm test: code = 8
- Piezo calibration: code = 4

### **Spare (0x55)**

Spare register.

### **Total Maintenance Event Counter (0x56)**

This reads the total number of gas check events that have been stored in the unit

### **Calibration Running Time in Seconds, Hi Word (0x57)**

This register reads the high word of the running time in seconds when the calibration event occurred. This time is in seconds since January 1, 2000.

### **Calibration Running Time in Seconds, Low Word (0x58)**

This register reads the low word of the running time in seconds when the calibration event occurred. This time is in seconds since January 1, 2000.

### **Calibration Clock Time: Year, Month (0x59)**

These registers are described in the Event Logging Registry Table as item number 1.

### **Calibration Clock Time: Day, Hour (0x5A)**

These registers are described in the Event Logging Registry Table as item number 2.

### **Calibration Clock Time: Minute, Seconds (0x5B)**

These registers are described in the Event Logging Registry Table as item number 3.

### **Calibration Code (0x5C)**

This returns 1 for zero events and 2 for calibration events.

### **Spare (0x5D)**

Spare register.

### **Total Calibration Event Counter (0x5E)**

This reads the total number of calibration events that have been stored in the unit.

### **Clear all events (0x5F)**

Writing zero (0) to this register clears all event counters.

### **Setting Clock**

See the [Table 26 Event Logging Registry Table](#).

*Table 26 Event Logging Registry Table*

Address (hex)	Parameter	Function	Data Type	Data range	Access
30	Seconds Time Hi	Seconds Time Hi	Numeric value	0 – 65535	Timer Sec
31	Seconds Time Low	Seconds Time	Numeric value	0 – 65535	Timer sec
32	Real Time Clock Year, Month	Read/Set year and month of RTC	2 Numeric Values	0-99 year, 1 – 12 month	Timer Struct
33	Real Time Clock Day, Hour	Read/Set day and hour of RTC	2 Numeric Values	1 – 31 day, 0 – 23 hour	
34	Real Time Clock Minute, Second	Read/Set minutes and seconds of RTC	2 Numeric Values	0 – 59 minute, 0 – 59 second	Timer Struct
35	PowerCycleFlag	Read Power Cycle Flag.	Numeric Value	1 – Time Not Reset; 0 – Time Reset	Flag
36	Event Index	Event index of Logged Event	Numeric value	0 - 9	Index
37	Warn Seconds Time Hi	Seconds Time Hi for warning event log entries	Numeric value	0 – 65535	Warn
38	Seconds Time Low	Seconds Time Low for warning event log entries	Numeric value	0 – 65535	Warn
39	Structure time Hi	Hi byte – year, low byte – month for warning event log entries	Numeric value	0 – 65535	Warn
3A	Structure time Mid	Hi byte – day, low byte – hour warning event log entries	Numeric value	0 – 65535	Warn
3B	Structure time Low	Hi byte – min, low byte – sec for warning event log entries	Numeric value	0 – 65535	Warn
3C	Reserved	Reserved	Numeric value	0	
3D	Reserved	Reserved	Numeric value	0	
3E	Warn Event Count	Warning Event Count	Numeric value	0 – 65535	Warn
3F	Alarm Seconds Time Hi	Seconds Time Hi for alarm event log entries	Numeric value	0 – 65535	Alarm
40	Seconds Time Low	Seconds Time Low for alarm event log entries	Numeric value	0 – 65535	Alarm
41	Structure time Hi	Hi byte – year, low byte – month for alarm event log entries	Numeric value	0 – 65535	Alarm
42	Structure time Mid	Hi byte – day, low byte – hour alarm event log entries	Numeric value	0 – 65535	Alarm
43	Structure time Low	Hi byte – min, low byte – sec for alarm event log entries	Numeric value	0 – 65535	Alarm
44	Alarm Detection Type and Peak dB	Alarm Detection Type and Peak dB	Numeric value	0-65535	Alarm
45	Reserved	Reserved	Numeric value	0	
46	Alarm Event Count	Alarm Event Count	Numeric value	0 – 65535	Alarm
47	Fault Seconds time Hi	Seconds Time Hi for fault event log entries	Numeric value	0 – 65535	Fault
48	Seconds time Low	Seconds Time Low for fault event log entries	Numeric value	0 – 65535	Fault
49	Structure time Hi	Hi byte – year, low byte – month for fault event log entries	Numeric value	0 – 65535	Fault
4A	Structure time Mid	Hi byte – day, low byte – hour alarm event log entries	Numeric value	0 – 65535	Fault

Address (hex)	Parameter	Function	Data Type	Data range	Access
4B	Structure time Low	Hi byte – min, low byte – sec for fault event log entries	Numeric value	0 – 65535	Fault
4C	Fault code	Fault code. Same code as register 2	Numeric value	0 – 65535	Fault
4D	Reserved	Reserved	Numeric value	0	
4E	Fault Event Count	Fault Event Count	Numeric value	0 – 65535	Fault
4F	Maintenance Seconds time Hi	Seconds Time Hi for event log entries	Numeric value	0 – 65535	Maintenance
50	Seconds time Low	Seconds Time Low for event log entries	Numeric value	0 – 65535	Maintenance
51	Structure time Hi	Hi byte – year, low byte – month for event log entries	Numeric value	0 – 65535	Maintenance
52	Structure time Mid	Hi byte – day, low byte – hour event log entries	Numeric value	0 – 65535	Maintenance
53	Structure time Low	Hi byte – min, low byte – sec for event log entries	Numeric value	0 – 65535	Maintenance
54	Maintenance code	Cal check	Numeric value	0	Maintenance
55	Reserved	Reserved	Numeric value	0	
56	Maintenance Count	Maintenance Count	Numeric value	0 – 65535	Maintenance
57	Calibrate Seconds Time Hi	Seconds Time Hi for event log entries	Numeric value	0 – 65535	Calibrate
58	Seconds Time Low	Seconds Time Low for event log entries	Numeric value	0 – 65535	Calibrate
59	Structure time Hi	Hi byte – year, low byte – month for event log entries	Numeric value	0 – 65535	Calibrate
5A	Structure time Mid	Hi byte – day, low byte – hour event log entries	Numeric value	0 – 65535	Calibrate
5B	Structure time Low	Hi byte – min, low byte – sec for event log entries	Numeric value	0 – 65535	Calibrate
5C	Calibrate code	Cal	Numeric value	0	Calibrate
5D	Reserved	Reserved	Numeric value	0	
5E	Calibrate Count	Calibrate Count	Numeric value	0 – 65535	Calibrate
5F	Reset Event Counters	Reset Event Counters	Numeric value	1	Reset

### 6.8.5 User Data (60H – 6F)

There is a section in memory that allows the user to store information. This is useful if the physical location or other user identification is required. The only restriction on the information is it must be Modbus compatible. Only one word can be written per command. There are a total of 16 words for the user.

### 6.8.6 Comm 2 Bus Activity Rate % (71H)

A read indicates the Comm 2 Bus Activity Rate in percent of this slave's addressed node versus other addressed nodes. Range of this value is in hex (0-64), which translates to decimal (0-100%).

### 6.8.7 Comm 2 Function Code Errors (72H)

A read indicates the number of Comm 2 Function Code Errors that occurred in the slave device. The maximum count is 65535 and then the counter rolls over to zero and begins counting again.

### 6.8.8 Comm 2 Starting Address Errors (73H)

A read indicates the number of Comm 2 Starting Address Errors that occurred in the slave device. The maximum count is 65535 and then the counter rolls over to zero and begins counting again.

### 6.8.9 Comm 2 Total Receive Errors (74H)

A read indicates the total Modbus Comm 2 Only Receive Errors that occurred in the slave device. These are address, function, etc. type of errors. The maximum count is 65535 and then the counter rolls over to zero and begins counting again.

### 6.8.10 RXD CRC Errors Hi (75H)

A read indicates the number of RXD CRC Errors that occurred in the slave device. The maximum count is 65535 and then the counter rolls over to zero and begins counting again.

### 6.8.11 RXD CRC Errors Lo (Same as Hi) (76EH)

**NOTE:** Hi and Lo CRC errors are reported in the same word. A read from either Hi or Lo will return the same count.

### 6.8.12 Comm 2 Parity Errors (77H)

A read indicates the number of Comm 2 Parity Flag Errors that occurred in the slave device. The maximum count is 65535 and then the counter rolls over to zero and begins counting again.

### 6.8.13 Comm 2 Overrun Errors (78H)

A read indicates the number of Comm 2 Only Overrun Errors that occurred in the slave device. The maximum count is 65535 and then the counter rolls over to zero and begins counting again.

**NOTE:** An overrun error occurs when the next received byte of data tries to overwrite an existing received data byte, which has not been processed. Therefore, the next received byte of data is lost. This can be controlled by implementing the proper DCS or PLC Error Handling Timing Setting (ex. Reply Timeout Setting, Delay Time, and Number of Retries) and proper Baud Rate Setting.

### 6.8.14 Comm 2 Framing Errors (79H)

A read indicates the number of Comm 2 Framing Errors that occurred in the slave device. The maximum count is 65535 and then the counter rolls over to zero and begins counting again.

### 6.8.15 Comm 2 Total Receive Errors (7AH)

A read indicates the total Modbus Comm 2 Only Receive Errors that occurred in the slave device. The maximum count is 65535 and then the counter rolls over to zero and begins counting again.

### 6.8.16 Modbus Cal Error (7BH)

Calibrate error register is read only. A "1" shows there was a calibration error.

### 6.8.17 Clear Comm 2 UART Errors (7CH)

Writing a 0 to the bit activates the Clear Comm 2 UART Errors function, which resets all of the Modbus UART Error counters to zero. The function is active momentarily and will reset automatically after being used.

### 6.8.18 Clear Comm 2 Modbus Errors (7DH)

Writing a 0 to the bit activates the Clear Comm 2 Modbus Errors function, which resets all of the Modbus Error counters to zero. The function is active momentarily and will reset automatically after being used.

### 6.8.19 Input Voltage (8DH)

The Input voltage register is read only. A read returns the input voltage. This allows the user to remotely read the actual input voltage via Modbus.

### 6.8.20 Detection Mode (D9H)

Writing a 0 sets the unit to Classic Mode and a 1 sets the unit to Enhanced Mode.

### 6.8.21 Enhanced Analog Output Mode (DAH)

Writing a 1 sets the analog output to Discrete SPL mode (EAO1). Writing a 2 sets the analog output to Discrete mode (EAO2) and writing a 3 sets the analog output to Full SPL mode (EAO3).

### 6.8.22 Set Cut-off Frequency (E2H)

Writing a 0 sets the cut-off to low frequency and writing a 1 sets the cut-off to high frequency.

## 7 Customer Support

Area	Phone/Email
<b>UNITED STATES</b>	
16782 Von Karman Avenue Unit 14 Irvine, CA 92606	Phone: +1-949-581-4464. 800-446-4872 Email: info.gm@MSAsafety.com
<b>IRELAND*</b>	
Ballybrit Business Park Galway Republic of Ireland, H91 H6P2	Phone: +353-91-751175 Email: info.gmil@MSAsafety.com
<b>SINGAPORE</b>	
35 Marsiling Industrial Estate Road 3, #04-01 Singapore 739257	Phone: +65-6350 4500 Email: msa.singapore@MSAsafety.com
<b>MIDDLE EAST</b>	
PO Box 54910 Dubai Airport Free Zone United Arab Emirates	Phone: +971-299-6741 Email: gmdubai.main@msasafety.com

\*The Observer i is manufactured at this location

Additional locations can be found at our web site, [www.MSAsafety.com](http://www.MSAsafety.com).

### MSA Customer Support

Area	Phone/Email
<b>United States/International</b>	
MSA Corporate Center: 1000 Cranberry Woods Drive Cranberry Township, PA 16066 USA	Toll Free: +1-877-672-3473 Phone: +1-724-776-8600 Email: info@MSAsafety.com Email: msa.international@MSAsafety.com
<b>EUROPE</b>	
Thiemannstrasse-1 12059 Berlin, Germany	Phone: +49-(0)30 68 86-0 Email: info.de@MSAsafety.com

### 8 Additional Information

#### 8.1 Warranty

General Monitors, an MSA Company, warrants the Observer i to be free from defects in workmanship or material under normal use and service within two years from the date of shipment.

General Monitors will repair or replace without charge any such equipment found to be defective during the warranty period. Full determination of the nature of, and responsibility for, defective or damaged equipment will be made by General Monitors' personnel.

Defective or damaged equipment must be shipped to the General Monitors plant or representative from which the original shipment was made. In all cases this warranty is limited to the cost of the equipment supplied by General Monitors. The customer will assume all liability for the misuse of this equipment by its employees or other personnel.

All warranties are contingent upon proper use in the application for which the product was intended and does not cover products which have been modified or repaired without General Monitors' approval, or which have been subjected to neglect, accident, improper installation or application, or on which the original identification marks have been removed or altered.

Except for the express warranty stated above, General Monitors disclaims all warranties with regard to the products sold, including all implied warranties of merchantability and fitness and the express warranties stated herein are in lieu of all obligations or liabilities on the part of General Monitors for damages including, but not limited to, consequential damages arising out of, or in connection with, the performance of the product.

## 8.2 Specifications

<b>Detector Type</b>	Ultrasonic (acoustic) gas leak detector	<b>Input Power</b>	15-36 VDC, 250 mA max. 24 VDC, 170 mA nominal
<b>Background Noise</b>		<b>Relay Ratings (optional)</b>	8 A @ 250 VAC
<b>Rejection Method</b>	Artificial Neural Network (ANN)	<b>Current Output (sink or source)</b>	<b>Status Indications:</b> 0 mA: Start up, no power 1 mA: Pulsed acoustic error 3 mA: Unit inhibit <b>Classic Mode:</b> 4 – 20 mA, 40 – 120 dB (u) <b>ANN Mode:</b> 4 – 12 mA, 40 – 120 dB (u), 16 mA warning, 20 mA alarm
<b>Gas Leak Recognition Method</b>	Artificial Neural Network (ANN)		
<b>Min. Acoustic Det. Frequency (ANN Mode)</b>	12 kHz		
<b>Min. Detection Limit</b>	40 dB (u)		
<b>Min. Pressure Requirement</b>	2 BAR (29 psi)		
<b>Accuracy</b>	±3 dB		
<b>Self-test</b>	Performed every 15 minutes	<b>EMC/RFI</b>	EMC Directive 2004/108/EC EN 61000-6-2, EN 61000-6-4
<b>Response Time</b>	< 1 s (speed of sound)	<b>Serial Digital Communication</b>	HART, Modbus
<b>Detector Coverage (ref. Methane)</b>	<b>Enhanced Mode (ANN) (@ 0.1 kg/sec):</b> 17 m (56 ft.) for FQHI with 59 dB ANN Sensitivity Level (Default) Ultra-high to medium background noise 28 m (92 ft.) for FQLO with 54 dB ANN Sensitivity Level Medium to low background noise <b>Classic Mode (@ 0.1 kg/sec):</b> 7 m (23 ft.) with 84 dB Trigger Level (Ultra-high) 12 m (39 ft.) with 74 dB T.L. (High) 18 m (59 ft.) with 64 dB T.L. (Medium) 24 m (79 ft.) with 54 dB T.L. (Low) <b>ATEX/IECEX/UKCA/INMETRO:</b> Ex db ia IIB+H2 T6 Gb, Ex tb IIIC T85°C Db (Ta = -40°C to +60°C) <b>CSA:</b> Ex db ia IIB+H2 T6 Gb, Ex tb IIIC T85°C Db <b>FM/CSA:</b> Class I, Div. 1, 2 Groups B,C,D; Class II, Div. 1, 2 Groups E,F,G; Class III, T5 (Ta = -40°C to +60°C)	<b>Cable Requirements</b>	Max. cable length between Observer i and power source @ 24 VDC (20 ohm) 2.08 mm <sup>2</sup> (14 AWG) – 1,809 m (5,928 ft)
<b>Approvals Classification</b>		<b>Operating Temperature Range</b>	40°C to 60°C (-40°F to 140°F)
		<b>Operating Humidity Range</b>	0-95% RH, non-condensing
		<b>Housing</b>	Stainless Steel AISI 316L
		<b>Dimensions</b>	203 x 203 x 201 mm (7.99 x 7.99 x 7.91 in)
		<b>Weight</b>	7.5 kg (16.6 lbs)
		<b>Conduit Entries</b>	¾" NPT or M20 x 1.5
<b>Approvals</b>	ATEX, UKCA, CSA, FM, IECEX, INMETRO, CE, HART 6.0 registered FM certified to IEC 61508 (SIL 3)	<b>Mounting Holes</b>	2x mounting screws – M8 x 19 max
<b>Accessories</b>	1701 Test and Calibration unit	<b>Ingress Protection</b>	IP66 / Type 4X
<b>Device Drivers</b>	DDL, DTM available from generalmonitors.com	<b>Warranty</b>	2 years
		<b>Standard Configuration</b>	OBSERVERi-1-1-1-1-1-1

## 8.2.1 Electrical Specifications

Cable Requirements: 3-wire shielded cable. Maximum distance between Observer i and power source @ 24 VDC nominal with alarm relay energized and 20 mA source.

## Current vs. Input Voltage

Voltage	Normal mA	Peak Alarm mA
15	198	300
20	146	217
24	125	103
25	120	184
30	100	161
35	87	148

**Resistance of Copper Wire**

AWG	mm <sup>2</sup>	Ohms per Km	Ohms k feet
10	5.27	3.28	1.00
12	3.31	5.21	1.59
14	2.08	8.29	2.53
16	1.31	13.2	4.01
18	0.823	20.95	6.39
20	0.519	33.31	10.15

Based on a 24 volt supply and 15 volts at the Observer i the recommended wire sizes are shown below.

**24 VDC Cable Lengths**

AWG	mm <sup>2</sup>	FEET	METERS
10	5.27	15000	4573
12	3.31	9434	2880
14	2.08	5928	1809
16	1.31	2347	1136
18	0.823	2347	715
20	0.519	1478	450

Use the following formula to calculate the wire size:

Cable drop per wire equals  $(E_{in} - \text{voltage at instrument})/2 = (24 - 15)/2 = 4.5$  volts per wire

Resistance maximum equals cable drop divided by Current required by unit at voltage at unit

$R = 4.5/0.300 = 15$  ohms per cable

Ohms per cable divided by cable ohms per meter =  $15/3.28 = 4573$  meters for 10 AWG

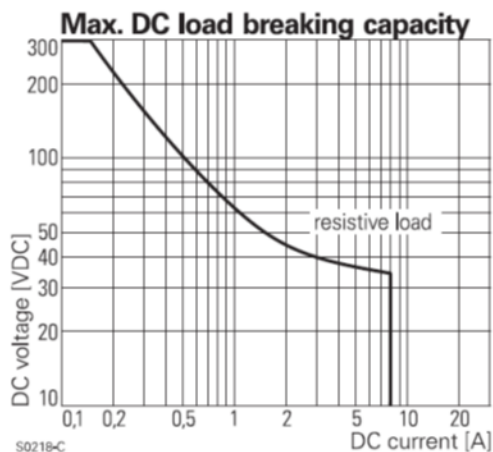

## Approvals

**CSA/FM:** Class I, Div. 1, 2 Groups B, C, and D  
Class II, Div. 1, 2 Groups E, F, G; Class III  
(Tamb=-40°C to +60°C) Type 4X

**CSA:** Ex db ia IIB+H<sub>2</sub> T6 Gb; Ex tb IIIC T85°C Db

**ATEX/IECEX/UKCA/INMETRO:** Ex db ia IIB+H<sub>2</sub> T6 Gb  
Ex tb IIIC T85°C Db  
(Tamb=-40°C to +60°C) IP66  
FM 11ATEX0003X, IECEX FMG 11.0003X, FM21UKEX0025X, NCC 18.0140X

**Functional Safety:** FM certified to IEC 61508 as SIL 3 suitable

### HART Registered:

Approved by the HART Communication Foundation. Compatible with Emerson 375 Field Communicator. Listed in Emerson Process Management's Aware device list

**EMI/EMC:** EN 61000-6-2, EN 61000-6-4

## 8.3 Spare Parts and Accessories

To order spare parts and/or accessories, please contact the nearest General Monitors representative or General Monitors directly, and give the following information:

Part Number of Spare Part or Accessory  
Description of Spare Part or Accessory  
Quantity of Spare Part or Accessory

### Installation Drawings

805560: Wiring Drawing

### Calibration Equipment

80510-1: 1701 Portable Calibrator

### Spare Parts

Description	Part Number
Allen Screw M6x20	928-381
Lock Washer	928-651
O-ring	925-5108
Microphone	805773-1
Sound Source Assembly	805554-3
Magnet-stick	80499-1
Mounting Bracket and Hardware	80601-1
Windscreen	80333-1
Windscreen Support Assembly	805708-1
12 mm Ratcheting Wrench (for install and removal of microphone)	954-024
Relay Board Screw	805541-2
10mm Relay Board Spacer	928-459
Screw M4 x 16mm Relay Board Mounting	928-393

### 8.3.1 Replacing the Microphone

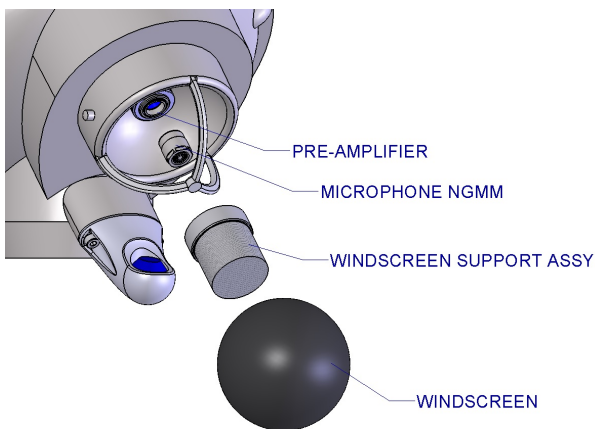

1. Pull out the foam windscreen and unscrew the windscreen support assembly.
2. Unscrew the microphone.
3. Check to make sure that the new microphone (805773-1) has two spring-pin contacts.  
**NOTE:** Be careful not to cross-thread the microphone as it is installed. It should screw in smoothly.
4. Replace the windscreen support assembly and then the windscreen.
5. Twist the windscreen back and forth a few times so that it seats properly over the support.
6. Calibrate the instrument per the calibration procedure.

### 8.3.2 Replacing the Sound Source Assembly (PN 805554-3)

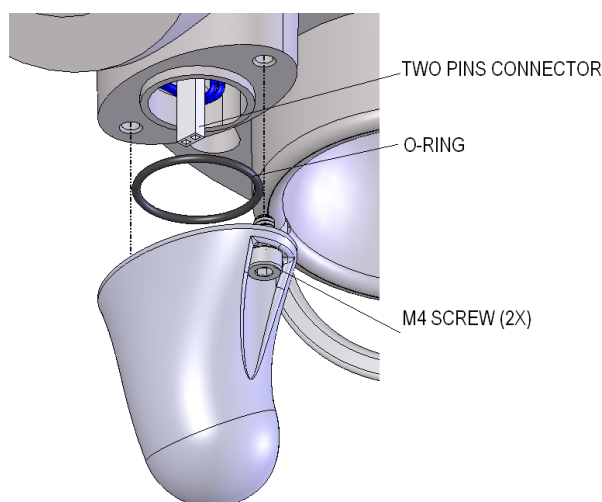

1. Loosen the 2 M4 screws.
2. Remove the old sound source assembly, and discard the O-ring.
3. Replace the new O-ring and plug the two-pin connector into the sound source assembly.
4. Tighten the two M4 screws.
5. Perform a Sound Source Calibration ([8.4 Sound Source Calibration](#)) and a Forced Acoustic Test, [4.5.2 Forced Acoustic Test](#).

## 8.4 Sound Source Calibration

### 8.4.1 Considerations and Preparations

When performing a sound-source calibration, the unit needs to be powered up and the operator has to have access to the detector. Furthermore, a magnet-stick is needed for this operation.

When performing the sound-source calibration make sure that nothing is blocking the path from the sound-source to the microphone. Furthermore, ensure that the operator does not hold his/her hands close to the detector when the sound-source calibration is being performed. It is advised to stand behind the sound-source when performing the calibration.

**NOTE:** Do NOT perform a sound source calibration unless you have replaced the sound source!

### 8.4.2 Sound-Source Calibration

Activate the UP-switch (▲) 7 times by means of the magnet-stick (7-UP). On the unit's display a "wait" indication will be seen for a few seconds. Afterward, an "S" will be displayed followed by the decibel (dB) level. This is the dB level output of the sound-source and should be a value between 84 dB and 100 dB.

When doing the "7-UP" the output level will default to the maximum level. This means that the sound level displayed will be at the maximum amplification.

**There are now two scenarios:**

#### 1. The sound level is between 80 dB and 110 dB.

This value can be directly saved as the sound-source reference level. Activating the ENTER-switch will save the sound-source reference level. The unit will display "DONE" for 3 seconds, which will indicate that the sound-source sound level reference was set to the dB level shown on the display and there after returns to normal operation.

**NOTE:** If no switch is activated for an interval longer than 1 minute, the unit will return to normal operation without setting the new reference.

#### 2. The sound level is lower than 74 dB.

If the sound level read-out is lower than 74 dB and the display is flashing, the sound-source tower should be replaced with a new tower, and the sound-source calibration procedure should be repeated.



## ADDENDUM

This product may contain hazardous and/or toxic substances.

EU Member states shall dispose according to WEEE regulations. For further WEEE disposal information please visit: **[www.MSAafety.com](http://www.MSAafety.com)**

All other countries or states: please dispose of in accordance with existing federal, state and local environmental control regulations.