

Alignment Guide— IR5500 Open Path Gas Detector



Before Getting Started

Ensure that there is a **clear**, unobstructed path between the Source and Receiver, and there is no significant amount of background gas when the unit is setting the zero value, as this will alter the IR5500's performance. Also, be sure to **measure** the distance between the Source and Receiver to determine the optimal adjustment (AJ) value. It is recommended that two people are involved in aligning the unit to speed up the process. One person should be at the **Source** and one person should be at the **Receiver**. An alignment scope is helpful but not necessary, though it is recommended for distances over 60m.

- ① Clear
- ② Measure
- ③ Source
- ④ Receiver

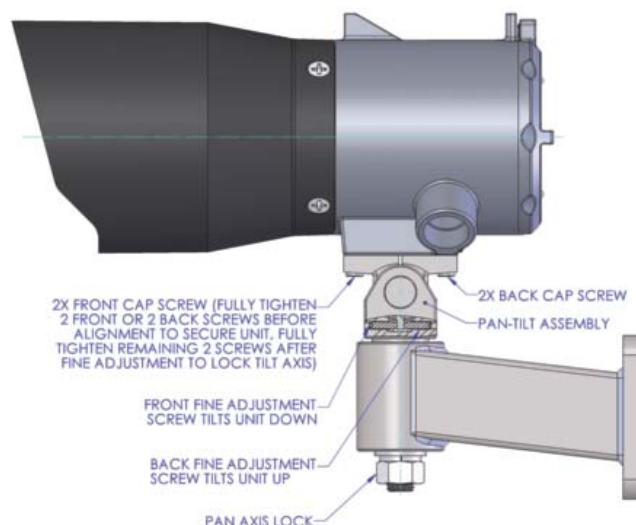

For both the **Source** and **Receiver**:

- Check the four cap screws that hold the unit to the pan-tilt assembly and verify that the *back two cap screws* have been *tightened* but the front two have not.
- On the pan-tilt assembly, verify that the front and back *fine adjust screws* are *flush* with the assembly surface, to allow full movement of tilt. If necessary, use a 2.5 mm hex wrench to adjust the screws.
- Use the housing sights to *aim the units at each other*. Align the notch and pin of the sights with the center of the opposing unit.
- Verify that the Receiver does not display a *fault code*.
 - To access the menu, place the magnet supplied with the IR5500 over the GM logo on the label of the Receiver for approximately five seconds. The display will cycle between the options:
 - rSt** Reset—Resets relays
 - Test
 - SE** Setup
 - in** Flash Input Diagnostics
 - AJ** Alignment/Adjustment—*remove magnet to select*
 - Fi** Finish, return to normal operation
- Remove the magnet when “**AJ**” appears to select Align/Adjustment.
- The Receiver will display “**Axx**” with an initial AJ “xx” value from 0 to 99 or “-” [“if no Source signal is detected.
- The goal is to set the **AJ value** in accordance with the following table dependent on the distance between the Source and Receiver. For example, if the Source and Receiver are 80 m apart the optimal AJ value would be between 35 and 43, with 43 being the optimal number for a standard configuration unit; or 60-65 for an extended range unit, with 65 being the optimal number.

STD. CONFIG. RANGE (20-100 m)	20 m	30 m	40 m	50 m	60 m	70 m	80 m	90 m	100 m
EXTENDED PATH RANGE (80-150 m)	N/A	80 m	90 m	100 m	110 m	120 m	130 m	140 m	150 m
AJ VALUE	72 to 67	65 to 60	59 to 54	53 to 48	49 to 43	45 to 38	43 to 35	39 to 32	35 to 30

NOTE: The alignment mode will time out in 60 minutes and return to run mode. If this occurs, reapply the magnet and return to alignment mode.



Because every life has a **purpose...**

You will now begin to align the system: **Source: Tilt, Pan | Receiver: Tilt, Pan**

1. The *front fine adjustment screw* *tilts the unit down*. Starting with the *Source*, lightly tighten the *front fine adjustment screw* until it meets some resistance. Slowly make a small turn to tighten the screw and lower the front of the unit. Wait a few seconds for the AJ number to settle at the Receiver. Continue making small turns, waiting after each turn for the AJ number to settle. Once the AJ number begins to decline, unscrew the front fine adjustment screw until it is flush with the assembly surface. *Always be sure to back out screw to avoid stripping.*
 2. Repeat the same procedure for the *back fine adjustment screw* on the unit. The *back fine adjustment screw* *tilts the unit up*. Lightly tighten the back fine adjust screw until it meets some resistance, and then slowly make a small turn to further tighten it. Wait a few seconds for the AJ number to settle on the Receiver. Continue until the AJ reaches its maximum and begins to decline. In most cases, the AJ won't be in the optimal range listed in the table since the Receiver hasn't been adjusted yet. Unscrew the back fine adjustment screw until it is flush with the assembly surface. *Always be sure to back out screw to avoid stripping.*
 3. Secure the two *front cap screws*. Verify that the AJ number does not decrease by more than 2 (an increase of any amount is acceptable). If it does decrease by more than 2, you will need to repeat steps 1 and 2.
 4. Adjust the *Source pan nut* for maximum AJ by first loosening the pan nut, moving the unit left or right to optimize the AJ number. Slowly tighten the nut at the bottom of the pan-tilt assembly while holding the left side of the Source. Verify that the AJ does not decrease by more than 2 (an increase of any amount is acceptable). If it does decrease by more than 2, you will need to repeat steps 1 - 3.
- With the Source now secure, repeat steps 1-4 for the tilt and pan with the *Receiver*.
 - Once the Receiver is secure, verify that the AJ is comparable to typical values listed in the above table.
 - At the Receiver, put the magnet on the GM logo to exit alignment mode. The unit will display a flashing "AC" and begin zeroing the gas reading. Once zeroing is complete, the unit will display "OC", and then return to normal operation (0). System alignment is now complete.
 - If you're having difficulty aligning the unit within the AJ values listed in the table, you can access the Flash Input Diagnostics mode via the menu, take note of the three values supplied and call Tech Support for further assistance.



Note: This Bulletin contains only a general description of the products shown. While uses and performance capabilities are described, under no circumstances shall the products be used by untrained or unqualified individuals and not until the product instructions including any warnings or cautions provided have been thoroughly read and understood. Only they contain the complete and detailed information concerning proper use and care of these products. Specifications subject to change without notice.



ID 1465-019-MC / April 2016
© MSA 2016 Printed in U.S.A.

Corporate Headquarters:
MSA – The Safety Company
1000 Cranberry Woods Drive
Cranberry Township, PA 16066
United States
+1-724-776-8600
info.us@MSAsafety.com

Design Center:
General Monitors
26776 Simpatica Circle
Lake Forest, CA 92630
United States
+1-949-581-4464
info.gm@MSAsafety.com

Additional locations can be found on our web site:
www.MSAsafety.com