



General Monitors

by MSA

MODEL IR5500

Infrared Open Path Detector for
Hydrocarbon Gas Applications



The information and technical data disclosed in this document may be used and disseminated only for the purposes and to the extent specifically authorized in writing by General Monitors.

Instruction Manual

05-24

General Monitors reserves the right to change published specifications and designs without prior notice.

**Part No.
Revision
CR**

**MANIR5500
R/05-24
800000065863**

This page intentionally left blank

TABLE OF CONTENTS

MODEL IR5500 I

INFRARED OPEN PATH DETECTOR FOR HYDROCARBON GAS APPLICATIONS..... I

QUICK START GUIDE..... VI

 System Mounting.....vi

 Conduit Sealing.....vii

 Terminal Connections.....viii

1.0 INTRODUCTION 1

 1.1 Protection for Life.....1

 1.2 Features and Benefits3

 1.3 Applications.....3

 1.4 System Integrity Verification.....4

2.0 PRODUCT DESCRIPTION 5

 2.1 General Description.....5

 2.1.1 Infrared Detection Principles5

 2.1.2 IR5500 Detection Method5

 2.1.3 Measurement Scale.....6

 2.1.4 Typical System Gas Cloud Measurements7

 2.1.5 Control Electronics8

3.0 INSTALLATION..... 9

 3.1 Receipt of Equipment.....9

 3.2 Location Considerations9

 3.3 System Mounting10

 3.4 Installation.....11

 3.5 Conduit Sealing.....12

 3.6 Terminal Connections13

 3.6.1 Terminal Block Operation.....15

 3.6.2 Terminal Functions.....16

 3.7 Applying Power and Alignment17

 3.7.1 Start-Up Checklist.....17

 3.7.2 Startup17

 3.7.3 Alignment and Adjustment.....18

 3.7.4 Response Test19

 3.7.5 Visible Light Filter.....19

 3.8 Operational Cautions20

 3.8.1 Rapid and Massive Liquid Propane Releases20

 3.8.2 Solutions to Guard against These Situations.....20

4.0 OPERATION..... 21

 4.1 Using the IR5500 Menus21

 4.2 Menu Options23

 4.3 Test “—”23

4.4	Setup “SE”	23
4.5	Flash Input “in”.....	33
4.6	Alignment/Adjustment “Pct” or “AJ”.....	35
4.7	Log – Fault Log and Zero	37
4.8	Finish “Fi”.....	39
4.9	Maintenance.....	39
4.10	Display and Fault Codes.....	39
4.11	LEL and ppm Negative Drift Faults.....	40
5.0	TROUBLESHOOTING.....	41
5.1	Fault Codes.....	41
5.1.1	F0 Excess Negative Drift.....	42
5.1.2	F1 Close to Low IR.....	42
5.1.3	F3 Beam Block.....	43
5.1.4	F4 IR Flash Timing.....	43
5.1.5	F5 Setup Menu.....	43
5.1.6	F6 Low Voltage Input at the Receiver.....	43
5.1.7	F7 Code Checksum.....	43
5.1.8	F8 Fault during Zeroing.....	43
5.1.9	F9 Gas Left.....	43
5.1.10	F10 Reset Short.....	43
5.1.11	F11 Receiver Overheating.....	44
5.1.12	F12 IR Flash Intensity Variation.....	44
5.1.13	F13 Non-Volatile Memory (NVM) Checksum	44
5.1.14	F14 Analog Output for LEL-m.....	44
5.1.15	F15 Receiver Heater	44
5.1.16	F16 High IR.....	45
5.1.17	F18 Dirty Lens.....	45
5.1.18	F19 Magnet.....	45
5.1.19	F20 Low Alignment Signal.....	45
5.1.20	F21 Zeroing	45
5.1.21	F22 RAM Checksum	45
5.1.22	F23 Hardware Revision.....	45
5.1.23	F24 Receiver Temperature Sensor	46
5.1.24	F25 Analog Output for ppm-m.....	46
5.1.25	tF6 Low Voltage Input at the Source.....	46
5.1.26	tF7 Source Heater.....	46
5.1.27	tF8 Source Overheating	46
5.2	Other Troubleshooting Tips.....	46
5.2.1	Source does not flash.....	46
5.2.2	Receiver does not display startup sequence when power is applied	47
5.2.3	Receiver displays]-[during alignment	47
5.2.4	Receiver displays F1 or F3 after alignment.....	47
5.2.5	Receiver does not respond to the magnet.....	47
5.2.6	Receiver signal level number went to 0 with no “A” on the display	47
5.2.7	Receiver displays information other than described	47
5.2.8	Source or Receiver will not move.....	47
6.0	CUSTOMER SUPPORT	48

7.0 APPENDIX.....	49
7.1 Warranty.....	49
7.2 Specifications	50
7.2.1 System Specifications.....	50
7.2.2 Electrical Specification.....	51
7.2.3 Mechanical Specification.....	51
7.2.4 Environmental Specification.....	52
7.2.5 Approvals	52
7.2.6 Cable Requirements.....	52
7.3 Spare Parts and Accessories	53
7.3.1 Spare Parts.....	53
7.3.2 Accessories	53
7.4 Engineering Documentation.....	54
8.0 APPENDIX A.....	55
8.1 Split-Range Analog Output Option	55
8.2 Alignment Using Legacy AJ Value.....	56

Table of Figures

Figure 1: IR5500 Open Path Gas Detector	1
Figure 2: Indoor Gas Cloud.....	6
Figure 3: Outdoor Gas Cloud	6
Figure 4: Outline and Dimensional Drawing with Mounting Options	10
Figure 5: Installation onto Mounting Arm.....	11
Figure 6: Source Wiring	13
Figure 7: Receiver Wiring	14
Figure 8: Terminal Block Operation Diagram	16
Figure 9: Relay Contact Protection for AC/DC Loads	17
Figure 10: IR5500 Main Menu Tree.....	22
Figure 11: IR5500 Beam Block Menu Tree	25
Figure 12: IR5500 Analog Output Menu Tree	28
Figure 13: IR5500 Alarm Menu Tree	30
Figure 14: IR5500 Channel Menu Tree	32
Figure 15: IR5500 Flash Input Menu Tree	34
Figure 16: IR5500 Alignment Menu Tree	36
Figure 17: IR5500 Fault Log Menu Tree.....	38
Figure 18: Outline Drawing	54

Table of Tables

Table 1: Readings of Methane Gas Clouds 0-5000 ppm•m Range	7
Table 2: Readings of Methane Gas Clouds 0-5 LEL•m Range	7
Table 3: Receiver Wiring Terminal Locations.....	15
Table 4: Locations	48
Table 5: Distances from Power Supply to Source and Receiver	52
Table 6: Distances from Receiver to Analog Output Load	53
Table 7: Typical AJ Signal Level Values	56

Quick Start Guide

System Mounting

The Model IR5500 units are shipped with either mounting assembly shown below. After the mounting location has been established, mount the support arm/base. Attach a pan-tilt assembly to each unit. Apply lithium grease on each taper joint before attaching a unit to a support arm/base. Add the supplied bolt and washers; do not tighten until unit is fully adjusted. If the bolt has been tightened and further adjustment is necessary, loosen the bolt two turns and use a screwdriver between the pan-tilt assembly and arm to release the taper.

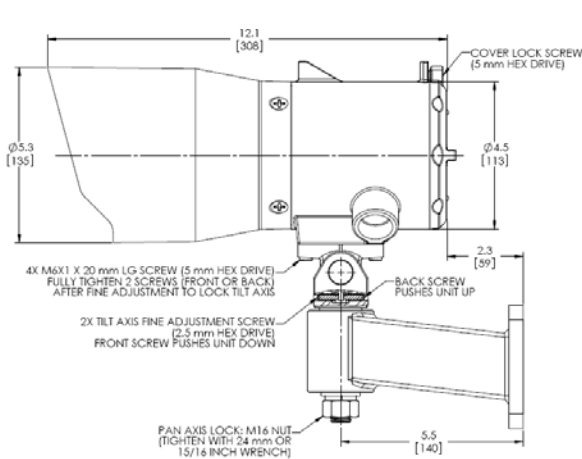

Arm Assembly with Fine Adjustments

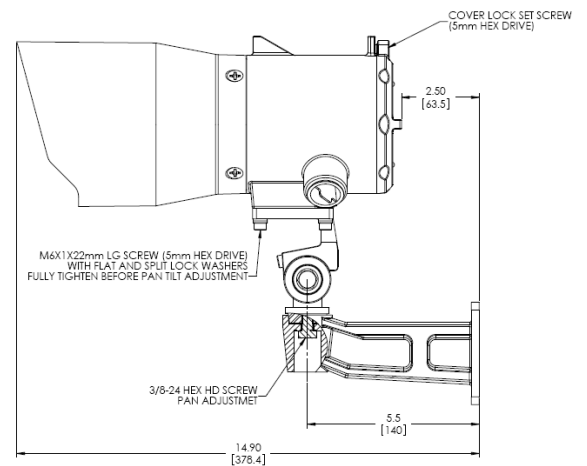

Basic Arm Assembly

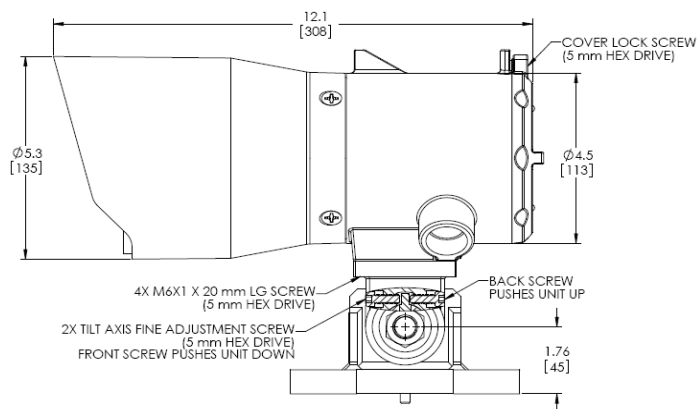

Base Assembly with Fine Adjustments

Conduit Sealing

Each conduit run from a hazardous to a non-hazardous location should be sealed so that gas or flames cannot pass from one electrical installation to another through the conduit system. A conduit seal must also be installed within 18 inches of the Source and Receiver enclosure if installed in a Division 1 location. A conduit seal may not be required if installed in a Division 2 location.

General Monitors requires the use of a drain loop or conduit seal in the conduit to prevent moisture from entering the unit housing. For installation in a Division 2 location using Division 2 wiring methods, a drain loop or conduit seal may not be required. Consult Article 501 of the NEC for details.



WARNING: The conduit entries should be sealed per the NEC 501.15 or Canadian Electrical Code Handbook (Part 1, Section 18-154) for Division 1 installations.

WARNING: Unused cable entry holes must be sealed with an approved explosion-proof stopping plug.



CAUTION: Acetic acid will damage metal components, hardware, and other components. If damage results from the use of a sealant that outgases acetic acid such as a room temperature vulcanizing sealant (RTV), the two-year warranty will be void.

CAUTION: Consult the manufacturer for dimensional information on the flameproof joints for repair.

Terminal Connections

To make the wiring connections to the Model IR5500, loosen the retaining screw on the cover of each unit using the supplied hex wrench and unscrew the rear cover. All output connections are made inside the housing (see figures on following page for terminal block locations). Recommended stripping length is 4/10" (10 mm) for push terminals, 1/2" (11 mm) for screw terminals.

NOTE: Contact with printed circuit board (PCB) components should be avoided to prevent damage by static electricity.

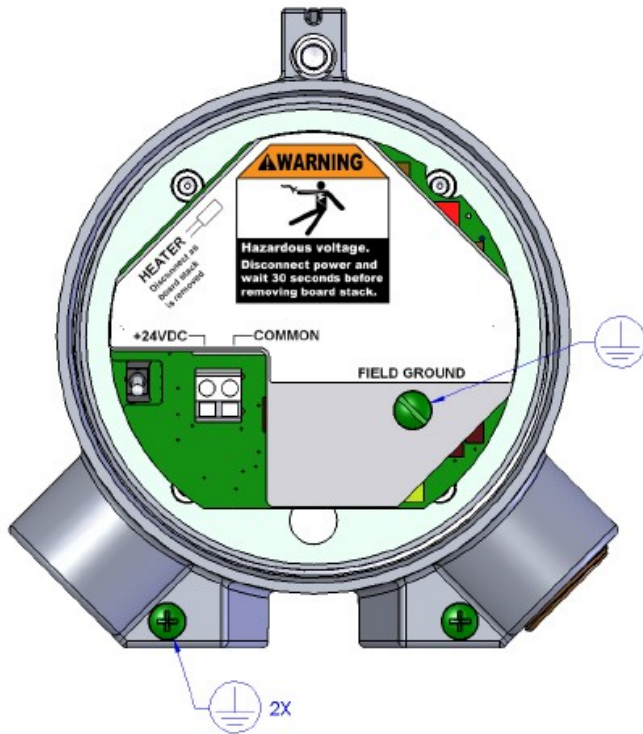

IR5500 SOURCE WITH COVER REMOVED

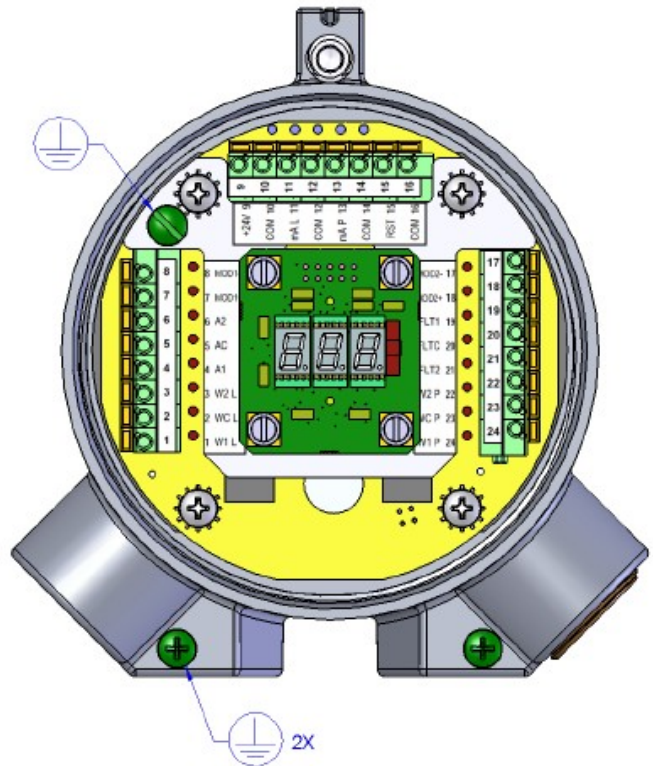

IR5500 RECEIVER WITH COVER REMOVED

9	10	11	12	13	14	15	16
+24V	COM	0-20mA L	COM	0-20mA P	COM	RST	COM

8	MOD1-	Modbus1-		Normally De-energized	Normally Energized		Modbus2-	MOD2-	17	
	7	MOD1+					Modbus1+	Modbus2+	MOD2+	18
6	A2	Alarm NO	Alarm NC	Normally Energized	Normally De-energized		FaultNO	FaultNO	FLT1	19
5	AC	Alarm C	Alarm C				FaultC	FaultC	FLTC	20
4	A1	Alarm NC	Alarm NO				FaultNC	FaultNC	FLT2	21
3	W2 L	Warn LEL•m NO	Warn LEL•m NC	Warn ppm•m NC	Warn ppm•m NO	W2 P	22			
2	WC L	Warn LEL•m C	Warn LEL•m C	Warn ppm•m C	Warn ppm•m C	WC P	23			
1	W1 L	Warn LEL•m NC	Warn LEL•m NO	Warn ppm•m NO	Warn ppm•m NC	W1 P	24			

Receiver Wiring Terminal Locations

Terminal Block Operation

To connect wiring to the terminal block, insert a screwdriver into the orange tab and press down, opening the terminal (see figure below). Insert the wire into the terminal and release the orange tab, clamping the wire in the terminal. Check the clamp by GENTLY tugging the wire to ensure it is locked in. Make sure that the terminal clamps on to the wire, not the insulation.

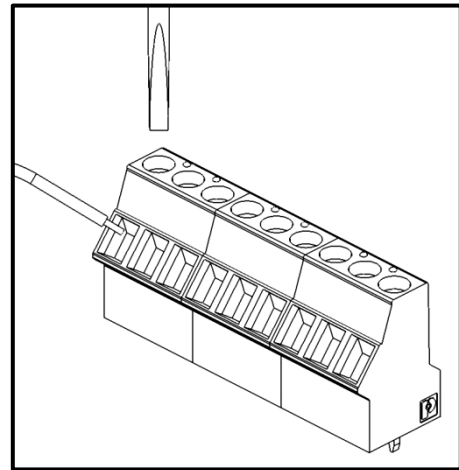
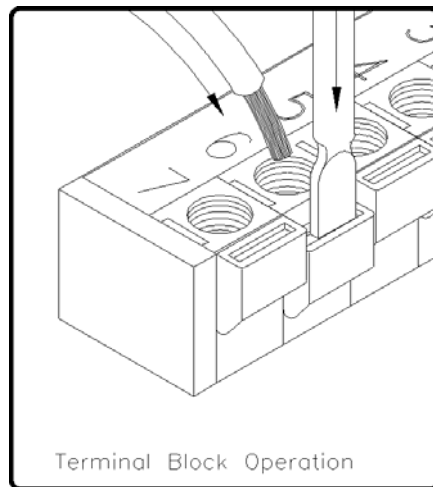

Terminal Block Operation Diagram

The push terminal block is designed to accept 24 AWG to 16 AWG (0.2 mm² to 1.5 mm²) stranded or solid-wire. The optional screw terminal block accepts 26 AWG to 14 AWG (0.14 mm² to 2.5 mm²) wire.

Primary DC voltage power must be provided by the customer. Since the Model IR5500 Infrared Open Path System is designed to continuously monitor for leaks of combustible gas, a power switch is not included to prevent accidental system shutdown. Power must remain disconnected until all other wiring connections are made.

Startup

Before applying power to the system for the first time, all wiring connections should be checked and the housing cover securely fastened.

Display Sequence on Power Up

Display	Duration (s)
0 0 0	1
8.8.8. (Test all segments)	2
blank	3
Software revision letter	2
SU (Start Up)	120
0 (Gas Concentration)	Continuous

The IR5500 contains a heater circuit to remove condensation from the windows. The unit should be allowed to stabilize for approximately two hours before continuing with the setup mode.

The resolution of the display is the either 0.1 LEL•m or 100 ppm•m. Since HART, Modbus, and 4-20 mA outputs have more resolution, the least significant digit of the displayed value might not agree with that of other outputs due to rounding error.

Alignment/Adjustment

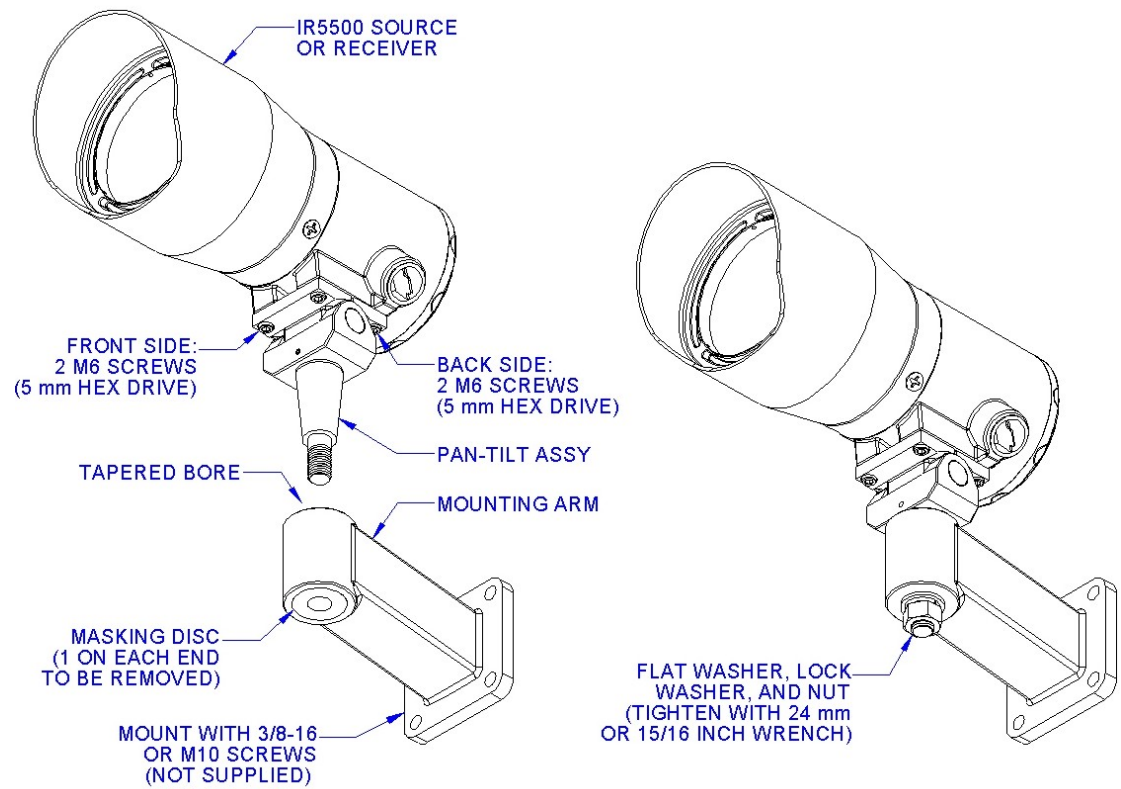

Ensure that there is no significant amount of background gas when the unit is setting the zero value, as this will alter the Model IR5500's performance. If there is gas present, try setting-up the IR5500 on a breezy day, as this dissipates the gas.

Alignment Outline

- Verify that the beam path is clear of all obstruction and that unit optics are clean.
 - Adjust units for maximum signal.
 - Adjust the Source first, then the Receiver.
 - Adjust pan first, then tilt.
 - Make sure that mounting screws are fully tightened.
 - Make sure that the Receiver displays 0C to complete alignment.
1. It is recommended that two people are involved in alignment. One person should be at the Source and one person should be at the Receiver. An alignment scope is helpful but not necessary.
 2. At the Receiver, check the four M6 screws that hold the unit to the pan-tilt assembly. Ensure that a small amount of anti-seize lubricant (p/n 2421) has been applied to the first few threads of each M6 screw. A packet of lubricant is included with the pan/tilt assembly. Without lubricant, alignment will be more difficult, and bolts may seize. Verify that the back two screws have been hand-tightened but that the front two have not. Hand-tighten the 24 mm nut for the pan-tilt assembly. On the assembly, verify that the front and back fine adjust screws are flush with the assembly surface, to allow full movement of tilt. If necessary, use a 2.5 mm hex wrench to adjust the screws. Align the notch and pin of the sights with the Source center.
 3. At the Source, adjust the Source pan (side-to-side) for maximum signal level. Slowly tighten the 24 mm nut at the bottom of the pan-tilt assembly while holding the left side of the Source. Verify that the signal level is reduced by 10% or less.
 4. At the Source, check the four M6 screws that hold the unit to the pan-tilt assembly. Verify that the back two screws have been hand-tightened but that the front two have not. On the pan-tilt assembly, verify that the front and back fine adjust screws are flush with the assembly surface. Use the housing sights to aim the unit at the center of the Source. Verify that the Receiver display is 0. If the Receiver does not have adequate signal from the Source, it may be in fault, depending on fault delay settings. Put the magnet on the upper right edge of the display over the GM logo. The display will change from 0 to rst, —, SE, in, and Pct or AJ. To align the system using AJ, refer to the Appendix. To align the system using Pct, remove the magnet when Pct appears. Apply the magnet when Pth appears. Select the units for the path length, enter the path length (LEn), and whether or not there is an attenuator in the Source (nAt/At, for 5-30m range systems only), whether or not there is a visible light filter in the Source (nLF/LF), and Fi to finish the Pth menu. The path length entered (LEn) should be accurate to within $\pm 5\%$ of the actual distance. The Receiver will display a number that is a percent of expected signal level. Aim for 100 percent or higher. The minimum acceptable percent is 80. Below 50, the alignment fault F20 will be set.
 5. At the Source, lightly tighten the front fine adjust screw until it bottoms out against the internal tilt lever. Slowly make a small turn to tighten the screw and lower the front of the Source. Wait a few seconds for the signal level number at the Receiver to settle. Continue making small turns, waiting after each turn for the signal level number to settle. Once the signal level number begins to decline, back out the front fine adjust screw until it is flush with the assembly surface. Lightly tighten the back fine adjust screw until it bottoms out, and then slowly make a small turn to further tighten it. Wait a few seconds

for the signal level number to settle. Continue until the signal level reaches its maximum and begins to decline. Back out the back fine adjust screw.

6. Secure all four M6 mounting screws, tightening them gradually and alternately in a crisscross pattern to minimize change in alignment. Verify that signal level is reduced by 10% or less (increase of any amount is acceptable). **To complete alignment, all four M6 mounting screws and the 24 mm nut of the pan/tilt assembly must be fully tightened and secure.**
7. With the Source secure, repeat steps 3 through 6 for the Receiver. The Pct should be at least 80 percent. Aim for 100 percent or higher.
8. Once adjusts are done and the signal level has been maximized, put the magnet on the upper right edge of the display to exit alignment mode. The unit will display a flashing AC and begin zeroing the gas reading. Once zeroing is complete, the unit will display 0C, followed by the gas concentration. **To complete alignment, 0C must be displayed.** With all screws secured on both units, once 0C is displayed, system alignment is complete.

Response Test

After initial alignment, a test of the IR5500 should be carried out using the test gas films for methane or propane (part numbers 329083 or 329084, respectively). Follow the instructions listed on the films.

1.1 Introduction

1.1 Protection for Life

General Monitors' mission is to benefit society by providing solutions through industry leading safety products, services, and systems that save lives and protect capital resources from the dangers of hazardous flames, gases, and vapors.

This manual provides instruction for installing and operating General Monitors' Model IR5500 for combustible gas detection. It should be read in full and the information contained herein understood before attempting to place the system in service.

The safety products you have purchased should be handled carefully and installed, calibrated, and maintained in accordance with the respective product instruction manual. Remember these products are for your safety.

Specific Conditions of Use

1. Consult the manufacturer for dimensional information on the flameproof joints for repair.
2. Parts of the equipment and the painted surface of the IR5500 Source or IR5500 Receiver may store electrostatic charge and become a source of ignition in applications with a low relative humidity <~30% relative humidity where the parts and the painted surface is relatively free of surface contamination such as dirt, dust, or oil. Guidance on protection against the risk of ignition due to electrostatic discharge can be found in EN TR50404 and IEC TR60079-32-1 (in preparation). Cleaning of the parts and painted surface should only be done with a damp cloth.

Special Warnings

The Model IR5500 Infrared Open Path System contains components which can be damaged by static electricity. Special care must be taken when wiring the system to ensure that only the connection points are touched.



WARNING: Toxic, combustible, and flammable gases and vapors are dangerous. Extreme caution should be used when these hazards are present.

Do not open when an explosive atmosphere is present.

Potential electrostatic charging hazard. Use only a damp cloth for cleaning.



CAUTION: Read and understand this instruction manual before operating or servicing the equipment.

Seal all conduits within 18 inches of enclosure.

Use wire suitable for 16°C above ambient for the Receiver and 32°C above ambient for the Source.



Fig. 1 IR5500 Open Path Gas Detector

1.2 Features and Benefits

The advantageous features and benefits of the Model IR5500 Infrared Open Path System include:

- **Performance certified:** only open path detector to meet multiple agency performance requirements on both the LEL•meter and ppm•meter scales.
- **Single detection beam:** eliminates drift and false alarms.
- **Parts-per-million accuracy:** sensitive to low-level leaks.
- **Unitized design - digital readout, 4 relays and two 4 to 20 mA outputs:** wide variety of outputs.
- **Type 4X, IP66/IP67 weatherproof rating:** highly durable unit.
- **Fail-to-safe operation:** alerts user to fault in operation.
- **Automatic gain control:** compensates for dirty optics, rain, and fog.
- **Power supply input reversal protection:** protection against miswiring damage.
- **Dirty Window delay and Beam Block delay:** reduces maintenance and false alarms.

1.3 Applications

This is a partial list of applications suitable for the Model IR5500 Infrared Open Path System:

- **Compressor stations**
- **Drilling and production platforms**
- **Fence line monitoring**
- **Fuel loading facilities**
- **Gas turbines**
- **LNG/LPG processing and storage facilities**
- **Petrochemical plants**
- **Tank farms**
- **Wastewater treatment**

1.4 System Integrity Verification

Commissioning Safety Systems

Before power up, verify wiring, terminal connections and stability of mounting for all integral safety equipment including, but not limited to:

- **Power supplies**
- **Control modules**
- **Field detection devices**
- **Signaling or output devices**
- **Accessories connected to field and signaling devices**

After the initial application of power and any factory specified warm-up period to the safety system, verify that all signal outputs to and from devices and modules, are within the manufacturers' specifications. Initial alignment, alignment checking, and testing should be performed according to the manufacturers' recommendations and instructions.

Proper system operation should be verified by performing a full, functional test of all component devices of the safety system, ensuring that the proper levels of alarming occur. Fault detection should be verified.

Periodic Testing of Field Devices

Periodic testing or alignment should be performed per the manufacturers' recommendations and instructions. Testing and alignment procedures should include, but not be limited to:

- **Verify zero reading**
- **Verify gas reading by applying a Test Gas Film**
- **Verify integrity of all optical surfaces and devices**

When testing produces results outside of the manufacturers' specifications, repair, or replacement of the suspect device(s) should be performed as necessary. Test intervals should be independently established through a documented procedure, including a verification log maintained by plant personnel or third party testing services.

Periodic System Verification

The following system verifications should be performed at least annually:

- **Wiring, terminal connections and stability of mounting**
- **Proper system operation verified by performing a full, functional test of all component devices of the safety system, ensuring that the proper levels of alarming occur**
- **Fault circuit operation**

2.0 Product Description

2.1 General Description

The Model IR5500 Infrared Open Path System is a hydrocarbon gas detector (Figure 1). The system consists of a Source and a Receiver. Both units are calibrated at the factory and need no further alignment. The operation of the Model IR5500 can be checked by placing a Test Gas Film in front of the Receiver. The system requires only a periodic cleaning of the windows to assure dependable performance, and is recommended prior to zero check, test gas, and optical integrity testing. The Model IR5500 Infrared Open Path System continuously monitors hydrocarbon gases. The gas detection range of a Receiver calibrated for methane is 0 to 5,000 ppm•m and 0 to 5 LEL•m while that for propane it is 0 to 2,000 ppm•m and 0 to 1 LEL•m. The Receiver provides two 4 to 20 mA analog signals, one proportional to ppm•m and the other to LEL•m. Alarm and Fault relays, split range (A/O-ppm), Modbus, and HART outputs are optional.

The Model IR5500 Infrared Open Path System is easily aligned using the digital display and adjustable mounting arms, therefore does not require any bulky setup equipment such as digital volt meters and handheld alignment aids. For setups that require the distance from the Source to the Receiver to be greater than 100 meters, General Monitors offers an optical alignment scope that makes the initial alignment easier.

Prior revisions of the product were marked as the Ultima OPIR-5 Detector.

2.1.1 Infrared Detection Principles

Most gases absorb infrared radiation. Hydrocarbon gases absorb infrared radiation at specific wavelengths but with different degrees of absorption. Absorption of the radiation follows the Beer-Lambert Law, which states that the transmittance (T) of radiation through an absorbing medium decreases exponentially by the product of the absorption coefficient (A), the concentration (C), and the path length (L):

$$T = T_0 \exp(-ACL)$$

Here T_0 is the transmittance of light containing no absorbing medium.

2.1.2 IR5500 Detection Method

The Model IR5500 uses a single beam, dual wavelength method of infrared absorption detection. The gas absorbs one wavelength but not the other, which is the reference wavelength. By comparing the signals from these two wavelengths, the detector measures gas concentration. The reference wavelength is chosen to compensate for interferences that can otherwise occur from atmospheric variation, such as humidity, rain, dust, snow, fog, steam, and temperature. This method of detection comes under what is commonly known as the non-dispersive infrared (NDIR) absorption principle.

NOTE: Extremely dense fog, steam or interruption of the beam by an object or person may cause a system fault

2.1.3 Measurement Scale

With the Model IR5500 Open Path System, as there is no fixed path length, the reading is reported in concentration•meter. The Model IR5500 reports concentrations in the ppm•m range (highly sensitive to low levels of hydrocarbons) and the LEL•m range (large hazardous levels of hydrocarbons). The Model IR5500 display is auto-ranging. In general, an open path monitor can give similar responses to large, low concentration gas clouds and small, high concentration gas clouds as shown below. The Alarm setpoint should be equal to or less than the reading for a gas concentration of 60% LEL at the target gas cloud length.

Typical gas cloud configuration:

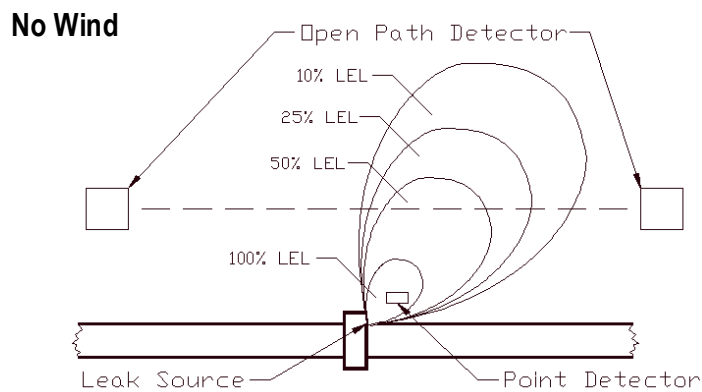

Fig. 2 Indoor Gas Cloud

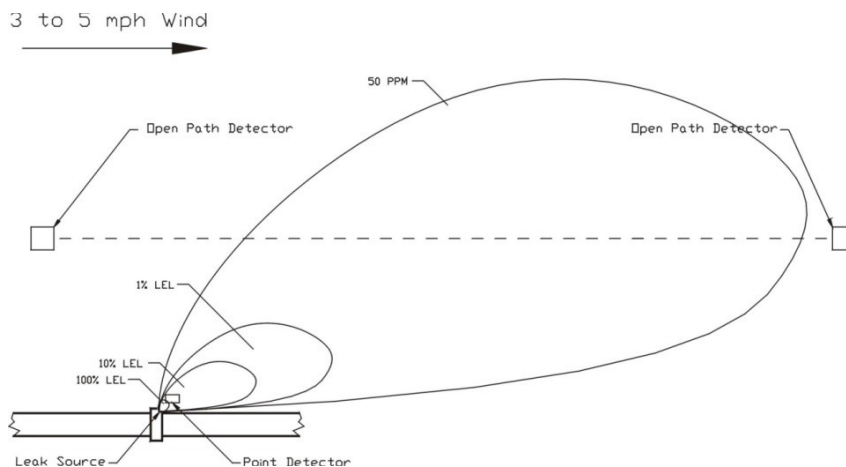

Fig. 3 Outdoor Gas Cloud

2.1.4 Typical System Gas Cloud Measurements

Example readings of methane gas clouds by the standard Model IR5500 are:

Size of Gas Cloud	IR5500 Display (ppm•m)
50 ppm x 2 meters	100
25 ppm x 4 meters	100
10 ppm x 10 meters	100
100 ppm x 5 meters	500
50 ppm x 10 meters	500
500 ppm x 5 meters	2500
100 ppm x 25 meters	2500
5% LEL x 1 meter	2500
1% LEL x 5 meters	2500
.5% LEL x 10 meters	2500

Table 1 Readings of Methane Gas Clouds 0-5000 ppm•m Range

Size of Gas Cloud	IR5500 Display (LEL•m)
20% LEL x 1 meter	0.2
10% LEL x 2 meters	0.2
100% LEL x 2½ meters	2.5
50% LEL x 5 meters	2.5
100% LEL x 1 meter	1.0
50% LEL x 2 meters	1.0
25% LEL x 4 meters	1.0
10% LEL x 10 meters	1.0

Table 2 Readings of Methane Gas Clouds 0-5 LEL•m Range

2.1.5 Control Electronics

Both the Model IR5500 Source and Receiver units operate from a 24 VDC input. This unregulated 24 VDC is fed to on-board power supplies that produce all necessary voltages for the Model IR5500 Source and Receiver.

In normal operation, the microprocessor program constantly monitors the two infrared wavelengths and performs mathematical operations on this information in conjunction with values obtained during the factory calibration process.

The microprocessor derives output information and feeds it to the digital to analog converter to produce two 4 to 20 milliampere (mA) signals that are proportional to the 0 to 5,000 ppm•m and 0 to 5 LEL•m for the methane sensing unit and 0 to 2,000 ppm•m and 0 to 1 LEL•m for the propane unit. The 4-20 mA signal is converted to gas concentration in % of full scale using the formula $[(\text{Analog Output} - 4)/16] * (100\% \text{ full scale})$, where Analog Output is the 4-20 mA signal.

The microprocessor program also monitors aspects of system operation such as supply voltage and optical path integrity.

3.1 Installation

3.1 Receipt of Equipment

Original shipping containers should be kept for future shipping or storage needs.

Shipping container contents should be carefully removed and checked against the packing list. If any damage has occurred or there is any discrepancy in the order, please notify General Monitors as soon as possible. All correspondence with General Monitors must specify the equipment part number and the serial number.

Each unit is tested by the factory; however, a complete system checkout is suggested upon initial installation to ensure system integrity.

3.2 Location Considerations

There are no standard rules for placement, since the optimum location varies with each application.

Some factors to consider when selecting locations are as follows:

- The system should be accessible for occasional response checks.
- The Receiver should be mounted so that the display is visible to aid in alignment.
- Do not mount near strong magnetic fields as degradation of performance may result.
- The line of sight between the Source and Receiver should be free from obstructions such as:
 - a parked truck or moveable machinery
 - frequent human or animal crossings
- Although the Source and Receiver are designed to resist radio frequency interferences, they should not be mounted close to radio sources or similar equipment.
- Mount the Receiver unit so that direct sunlight does not enter the front window.
- Locate the units away from concentrated sources of heat.
- Mount away from sources of excessive vibration and away from high voltage/high current power lines.
- If the path length is less than 20 meters (65 feet), a Source with an attenuator is required.

3.3 System Mounting

The Model IR5500 units are shipped with either mounting assembly shown in Figure 4. After the mounting location has been established, mount the support arm/base. Attach a pan-tilt assembly to each unit. Apply lithium grease on each taper joint before attaching a unit to a support arm/base. Add the supplied bolt and washers; do not tighten until unit is fully adjusted. If the bolt has been tightened and further adjustment is necessary, loosen the bolt two turns and use a screwdriver between the pan-tilt assembly and arm to release the taper.

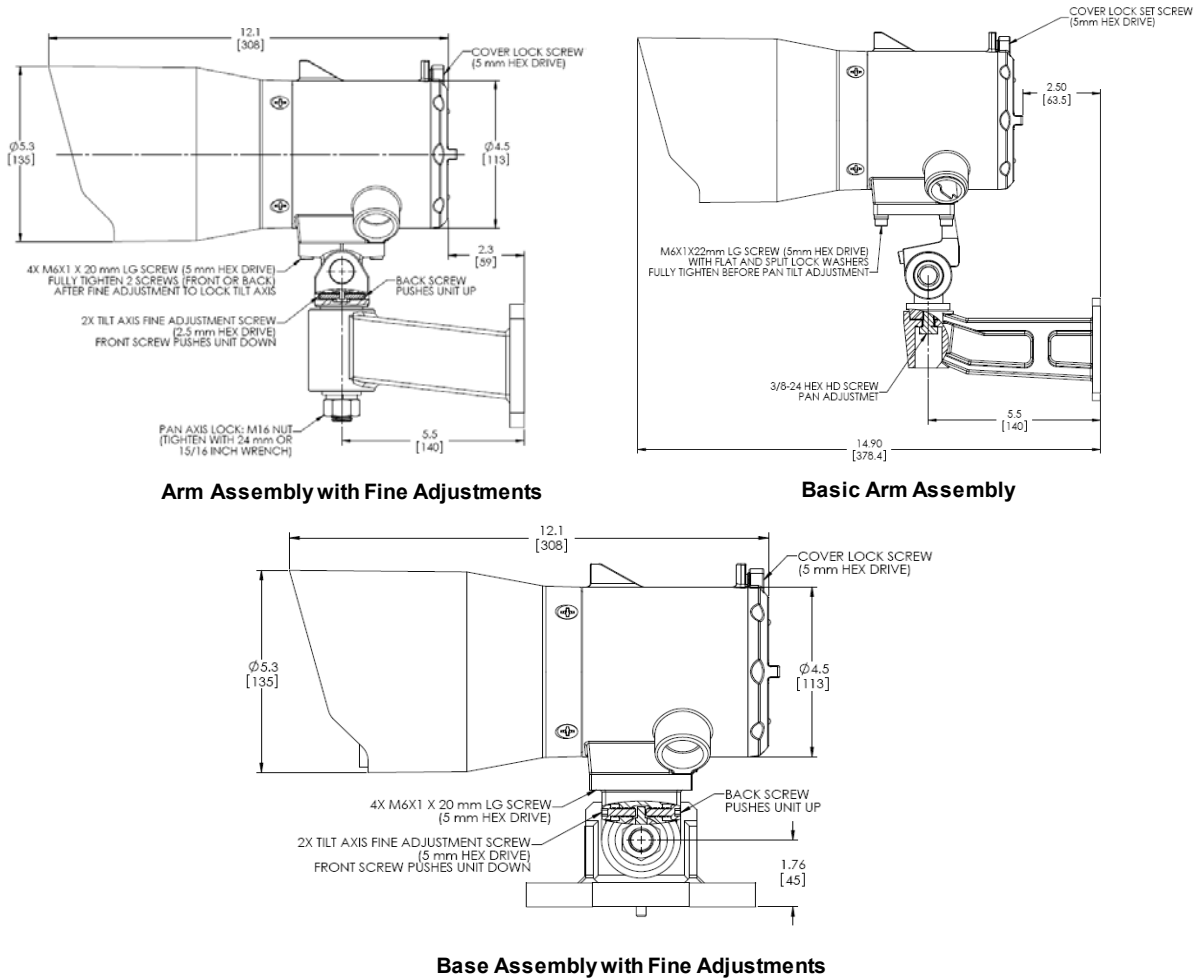

Fig. 4 Outline and Dimensional Drawing with Mounting Options

3.4 Installation

1. If necessary, remove the pan-tilt assembly from the arm. To do so, unscrew the 24 mm nut from the bottom of the pan-tilt. Remove the lock washer and flat washer. Put the washers and the nut in a secure place.
2. Put the source or the receiver unit on a work surface with the 4 mounting holes facing up. Align the 4 mounting holes of the pan-tilt assembly with those on the unit. Verify that the gap in the mounting surface of the pan-tilt assembly is across the unit rather than from front to back. Apply a small amount of anti-seize lubricant (p/n 2421) to the first few threads of each M6 screw. A packet of lubricant is included with the pan/tilt assembly. Without lubricant, alignment will be more difficult, and bolts may seize. Install the 4 screws without tightening the front two. Hand-tighten the back two screws.
3. Mount the unit and pan-tilt assembly on the arm. Install the washer, the lock washer, and the 24mm nut to the bottom of the pan-tilt assembly, without tightening the nut.
4. Verify that the front and back fine adjust screws for tilt are flush with the assembly surface, to allow full movement of tilt. If necessary, use a 2.5 mm hex wrench to adjust the screws.

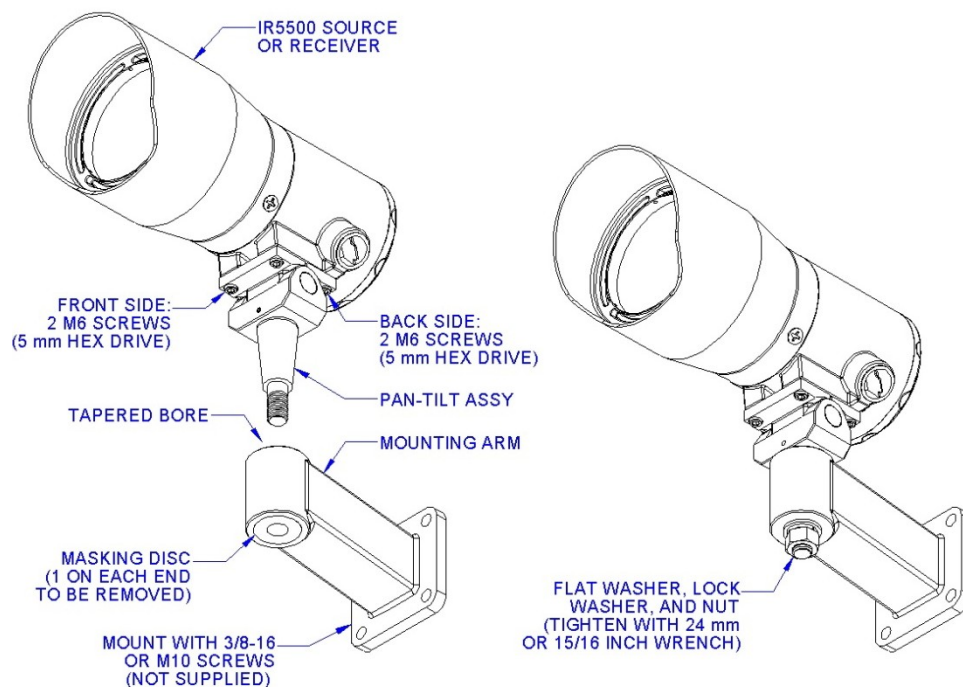

Fig. 5 Installation onto Mounting Arm

3.5 Conduit Sealing

Each conduit run from a hazardous to a non-hazardous location should be sealed so that gas or flames cannot pass from one electrical installation to another through the conduit system. A conduit seal must also be installed within 18 inches of the Source and Receiver enclosure if installed in a Division 1 location. A conduit seal may not be required if installed in a Division 2 location.

General Monitors requires the use of a drain loop or conduit seal in the conduit to prevent moisture from entering the unit housing. For installation in a Division 2 location using Division 2 wiring methods, a drain loop or conduit seal may not be required. Consult Article 501 of the NEC for details.



WARNING: The conduit entries should be sealed per the NEC 501.15 or Canadian Electrical Code Handbook (Part 1, Section 18-154) for Division 1 installations.

WARNING: Unused cable entry holes must be sealed with an approved explosion-proof stopping plug.



CAUTION: Acetic acid will damage metal components, hardware, and other components. If damage results from the use of a sealant that outgases acetic acid such as a room temperature vulcanizing sealant (RTV), the two-year warranty will be void.

CAUTION: Consult the manufacturer for dimensional information on the flameproof joints for repair.

3.6 Terminal Connections

To make the wiring connections to the Model IR5500, loosen the retaining screw on the cover of each unit using the supplied hex wrench and unscrew the rear cover. All output connections are made inside the housing (see figures on following page for terminal block locations). Stripping length is 4/10" (10 mm) for push terminals, 1/2" (11 mm) for screw terminals.

NOTE: Contact with printed circuit board (PCB) components should be avoided to prevent damage by static electricity.

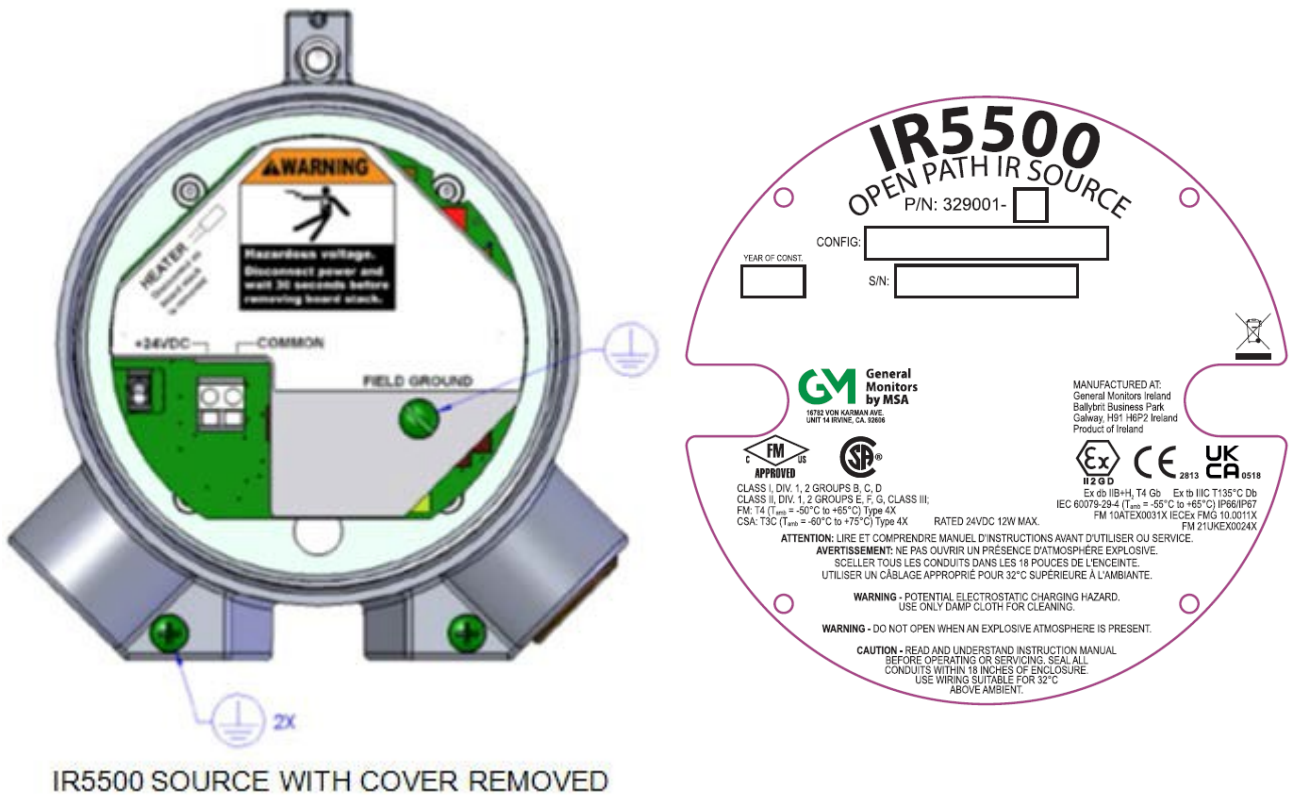

IR5500 SOURCE WITH COVER REMOVED

Fig. 6 Source Wiring

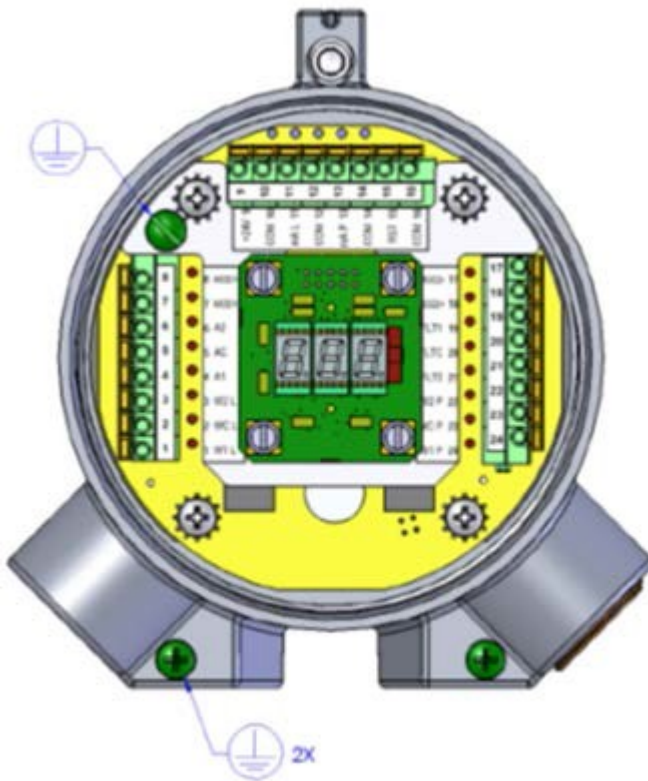

IR5500 RECEIVER WITH COVER REMOVED

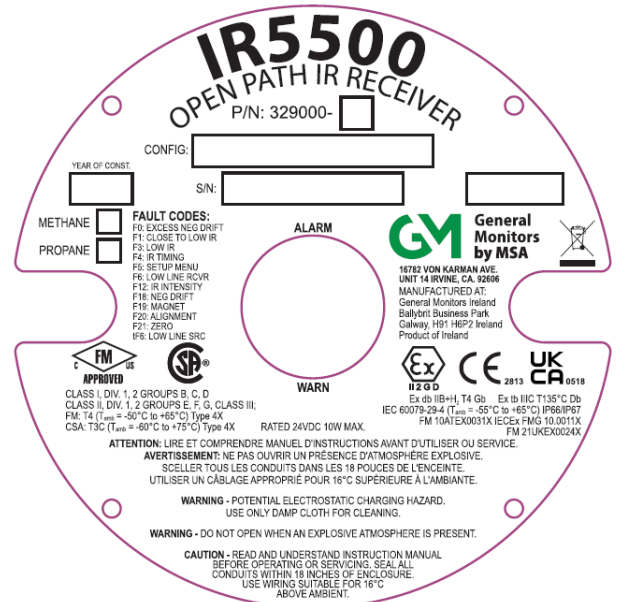

Fig. 7 Receiver Wiring

9	10	11	12	13	14	15	16
+24V	COM	0-20mA L	COM	0-20mA P	COM	RST	COM

8	MOD1-	Modbus1-			Modbus2-	MOD2-	17	
7	MOD1+	Modbus1+			Modbus2+	MOD2+	18	
		Normally De-energized	Normally Energized		Normally Energized	Normally De-energized		
6	A2	Alarm NO	Alarm NC		FaultNO	FaultNO	FLT1	19
5	AC	Alarm C	Alarm C		FaultC	FaultC	FLTC	20
4	A1	Alarm NC	Alarm NO		FaultNC	FaultNC	FLT2	21
3	W2 L	Warn LEL•m NO	Warn LEL•m NC		Warn ppm•m NC	Warn ppm•m NO	W2 P	22
2	WC L	Warn LEL•m C	Warn LEL•m C		Warn ppm•m C	Warn ppm•m C	WC P	23
1	W1 L	Warn LEL•m NC	Warn LEL•m NO		Warn ppm•m NO	Warn ppm•m NC	W1 P	24

Table 3 Receiver Wiring Terminal Locations

3.6.1 Terminal Block Operation

To connect wiring to the terminal block, insert a screwdriver into the orange tab and press down, opening the terminal. Insert the wire into the terminal and release the orange tab, clamping the wire in the terminal. Check the clamp by GENTLY tugging the wire to ensure it is locked in. Make sure that the terminal clamps on to the wire, not the insulation.

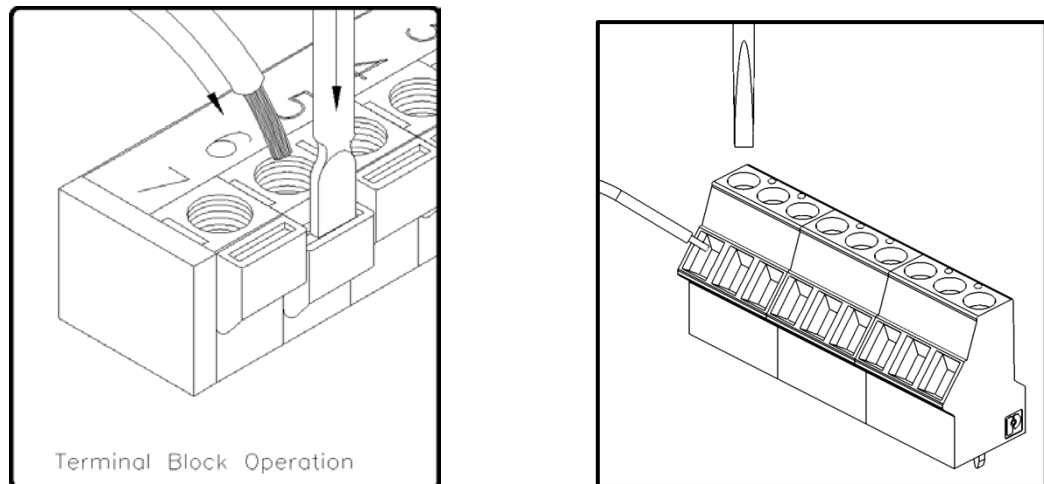

Fig. 8 Terminal Block Operation Diagram

The push terminal block is designed to accept 24 AWG to 16 AWG (0.2 mm² to 1.5 mm²) stranded or solid-wire. The optional screw terminal block accepts 26 AWG to 14 AWG (0.14 mm² to 2.5 mm²) wire. Use Copper, Copper-Clad Aluminum, or Aluminum Conductors.

Primary DC voltage power must be provided by the customer. Since the Model IR5500 Infrared Open Path System is designed to continuously monitor for leaks of combustible gas, a power switch is not included to prevent accidental system shutdown. Power must remain disconnected until all other wiring connections are made.

3.6.2 Terminal Functions

Reset

The Model IR5500 provides external Reset Switch terminations to allow remote resetting of the alarms. Connect each end of a normally open SPST momentary switch to RST and COM (refer to Table 3). To reset a latched relay, simply press and release the switch.

Relays

Inductive loads (bells, buzzers, and relays) on dry relay contacts must be clamped as shown in Fig. 6. Unclamped inductive loads can generate voltage spikes in excess of 1,000 volts. Spikes of this magnitude may cause false alarms and contact damage.

NOTE: All relay states shown with power applied.

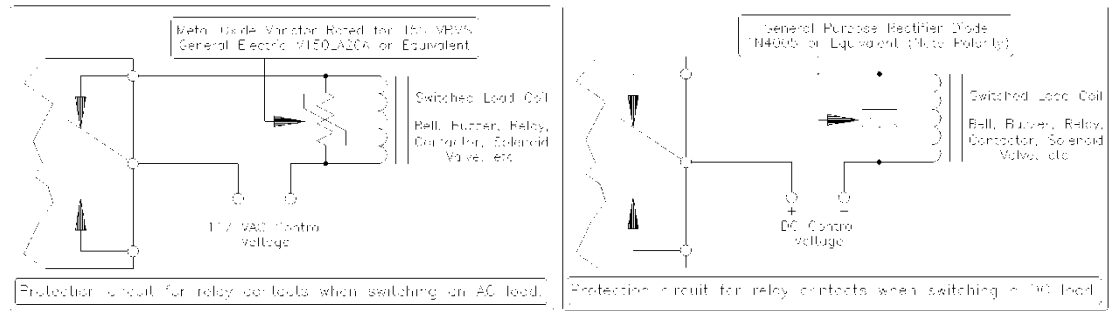

Fig. 9 Relay Contact Protection for AC/DC Loads

3.7 Applying Power and Alignment

3.7.1 Start-Up Checklist

Prior to starting the system, perform the following steps:

- Inhibit any external devices, such as a trip amplifier, a PLC, or a DCS system.
- Verify that optional settings are correct.
- Verify that the unit is properly mounted. Ensure the conduit/cable gland entries are pointed downward.
- Verify that the signal wiring is correct.
- Verify that the power supply is connected properly. The Model IR5500 is to be powered by 20 VDC to 36 VDC (24 VDC nominal) from a Class 2 power supply.
- Make sure the cover is securely installed or the area has been declassified.

3.7.2 Startup

Before applying power to the system for the first time, all wiring connections should be checked and the housing cover securely fastened.

Display Sequence on Power Up

Display	Duration
0 0 0	1 second
8.8.8. (Test all segments)	2 seconds
blank	3 seconds
Software revision letter	2 seconds
SU (Start Up)	2 minutes
0 (Gas Concentration)	Ongoing

The IR5500 contains a heater circuit to remove condensation from the windows. The unit should be allowed to stabilize for approximately two hours before continuing with the setup mode.

The resolution of the display is either 0.1 LEL·m or 100 ppm·m. Since HART, Modbus, and 4-20 mA outputs have more resolution, the least significant digit of the displayed value might not agree with that of other outputs.

3.7.3 Alignment and Adjustment

Ensure that there is no significant amount of background gas when the unit is setting the zero value, as this will alter the Model IR5500's performance. If there is gas present, try setting-up the IR5500 on a breezy day, as this dissipates the gas.

Alignment Outline

- Verify that the beam path is clear of all obstruction and that unit optics are clean.
 - Adjust units for maximum signal.
 - Adjust the Source first, then the Receiver.
 - Adjust pan first, then tilt.
 - Make sure that mounting screws are fully tightened.
 - Make sure that the Receiver displays 0C to complete alignment.
1. It is recommended that two people are involved in alignment. One person should be at the Source and one person should be at the Receiver. An alignment scope is helpful but not necessary.
 2. At the Receiver, check the four M6 screws that hold the unit to the pan-tilt assembly. Ensure that a small amount of anti-seize lubricant (p/n 2421) has been applied to the first few threads of each M6 screw. A packet of the lubricant is included with the pan/tilt assembly. Without lubricant, alignment will be more difficult, and bolts may seize. Verify that the back two screws have been hand-tightened but that the front two have not. Hand-tighten the 24 mm nut for the pan-tilt assembly. On the assembly, verify that the front and back fine adjust screws are flush with the assembly surface, to allow full movement of tilt. If necessary, use a 2.5 mm hex wrench to adjust the screws. Align the notch and pin of the sights with the Source center.
 3. At the Source, adjust the Source pan (side-to-side) for maximum signal level. Slowly tighten the 24 mm nut at the bottom of the pan-tilt assembly while holding the left side of the Source. Verify that the signal level is reduced by 10 % or less.
 4. At the Source, check the four M6 screws that hold the unit to the pan-tilt assembly. Verify that the back two screws have been hand-tightened but that the front two have not. On the pan-tilt assembly, verify that the front and back fine adjust screws are flush with the assembly surface. Use the housing sights to aim the unit at the center of the Source. Verify that the Receiver display is 0. If the Receiver does not have adequate signal from the Source, it may be in fault, depending on fault delay settings. Put the magnet on the upper right edge of the

display over the GM logo. The display will change from 0 to rst, ---, SE, in, and Pct or AJ. To align the system using AJ, refer to the Appendix. To align the system using Pct, remove the magnet when Pct appears. Apply the magnet when Pth appears. Select the units for the path length, enter the path length (LEn), and whether or not there is an attenuator on the Source (nAt/At, for 5-30m range systems only), whether or not there is a visible light filter in the Source (nLF/LF), and Fi to finish the Pth menu. The path length entered (LEn) should be accurate to within $\pm 5\%$ of the actual distance. The Receiver will display a number that is a percent of expected signal level. Aim for 100 percent or higher. The minimum acceptable percent is 80. Below 50, the alignment fault F20 will be set.

5. At the Source, lightly tighten the front fine adjust screw until it bottoms out against the internal tilt lever. Slowly make a small turn to tighten the screw and lower the front of the Source. Wait a few seconds for the signal level number at the Receiver to settle. Continue making small turns, waiting after each turn for the signal level number to settle. Once the signal level number begins to decline, back out the front fine adjust screw until it is flush with the assembly surface. Lightly tighten the back fine adjust screw until it bottoms out, and then slowly make a small turn to further tighten it. Wait a few seconds for the signal level number to settle. Continue until the signal level reaches its maximum and begins to decline. Back out the back fine adjust screw.
6. Secure all four M6 mounting screws, tightening them gradually and alternately in a crisscross pattern to minimize change in alignment. Verify that signal level is reduced by 10% or less (increase of any amount is acceptable). **To complete alignment, all four M6 mounting screws and the 24 mm nut of the pan/tilt assembly must be fully tightened and secure.**
7. With the Source secure, repeat steps 3 through 6 for the Receiver. The Pct should be at least 80 percent. Aim for 100 percent or higher.
8. Once adjusts are done and the signal level has been maximized, put the magnet on the upper right edge of the display to exit alignment mode. The unit will display a flashing AC and begin zeroing the gas reading. Once zeroing is complete, the unit will display 0C, followed by the gas concentration. **To complete alignment, 0C must be displayed.** With all screws secured on both units, once 0C is displayed, system alignment is complete.

3.7.4 Response Test

After initial alignment, a test of the IR5500 should be carried out using the Test Gas Films for methane or propane (part numbers 329083-1 or 329084-1, respectively). Follow the instructions on the films.

3.7.5 Visible Light Filter

One of the Model IR5500's configurations is equipped with a visible light filter. Such configuration can prove useful in installations where an intermittent light beam is considered disruptive to surrounding operations. A visible light filter blocks light in the visible portion of the electromagnetic spectrum, allowing the instrument to detect and measure hydrocarbon gas concentrations without the attendant effects of flashing light.

IR5500 detectors with a visible light filter should be installed as described in the installation section. Without the flashing light as a guide for alignment, users may need to use the Long Range Alignment Kit (part number 329082-1) to establish orientation and positioning of the receiver and source. The kit is recommended for separations of 50 meters or more.

The visible light filter should not be removed from the IR5500.

The filter is attached at the factory with a protective seal that prevents ingress of water and dust into the enclosure. If removed by accident, the source should be returned to the factory for repair.

3.8 Operational Cautions



WARNING: During operation, the line of sight between the Source and the Receiver should be free from blockage caused by frequent human or animal crossings. The IR5500 **will not** respond to gas leaks upon complete IR beam blockage. **Interruptions of the IR beam will delay the response time of this unit, and thus lead to a potentially unsafe situation.**

The Heavy Hydrocarbon version of the Model IR5500 Open Path System performs accurately and reliably for propane gas detection applications in extreme industrial environments. However, under certain conditions, the Heavy Hydrocarbon IR5500 could give a beam block indication rather than a gas reading or alarm.

3.8.1 Rapid and Massive Liquid Propane Releases

A sudden release of a large amount of liquid propane can form very cold gas clouds due to cooling resulting from gas expansion and liquid propane evaporation. This is an intrinsic problem for all open path optical detection technologies. Installing the Model IR5500 at a distance of at least 10 meters from potential liquid propane leakage will reduce this problem.

3.8.2 Solutions to Guard against These Situations

- Use complementary point detectors such as Models IR400, S4000CH, or S4100CH at potential sources of leaks of high concentration liquid propane
- Use the beam block signal as an alarm. To reduce the number of false alarms due to an actual physical beam block, there are user selectable time delays. A signal will then be given if a beam block exceeds the specified time delay.

The ppm·m range of the IR5500 should be used as a warning that there is a gas leak. This may allow action to take place before a leak reaches a hazardous level, while the LEL·m range should be used for a gas leak alarm.

NOTE: The IR5500 will detect hydrocarbons other than methane and propane. Consult the manufacturer for details regarding sensitivity to other hydrocarbons.

4.1 Operation

The Model IR5500 Open Path Gas Detector front panel includes an LED digital display, Alarm and Warning LEDs, and displays a set of menu options that provide the user with the most flexible detector system possible. In addition to the IR5500 menu options for operations and configuration tasks, there is an extensive set of Modbus and HART commands for the same tasks that can be sent from remote Modbus and HART devices in control room areas.

- The IR5500 menu options are described in detail in this section.
- Modbus commands are described in a separate Modbus programming manual available for download from the General Monitors website.
- HART commands are described in the HART Field Device Specification available for download from the General Monitors website.

4.1 Using the IR5500 Menus

The IR5500 menus allow the user to complete many operational tasks.

- Start the alignment of the Source and Receiver or initiate a gas check via Test Gas Mode.
- Configure the % LEL required to generate a Warning or Alarm, as well as the warning and alarm relay settings for Energized/De-energized and Latching/Non-Latching.
- Configure Modbus or HART communication settings.
- Select mirror image option for display (FLP).
- Select delays for beam block fault.

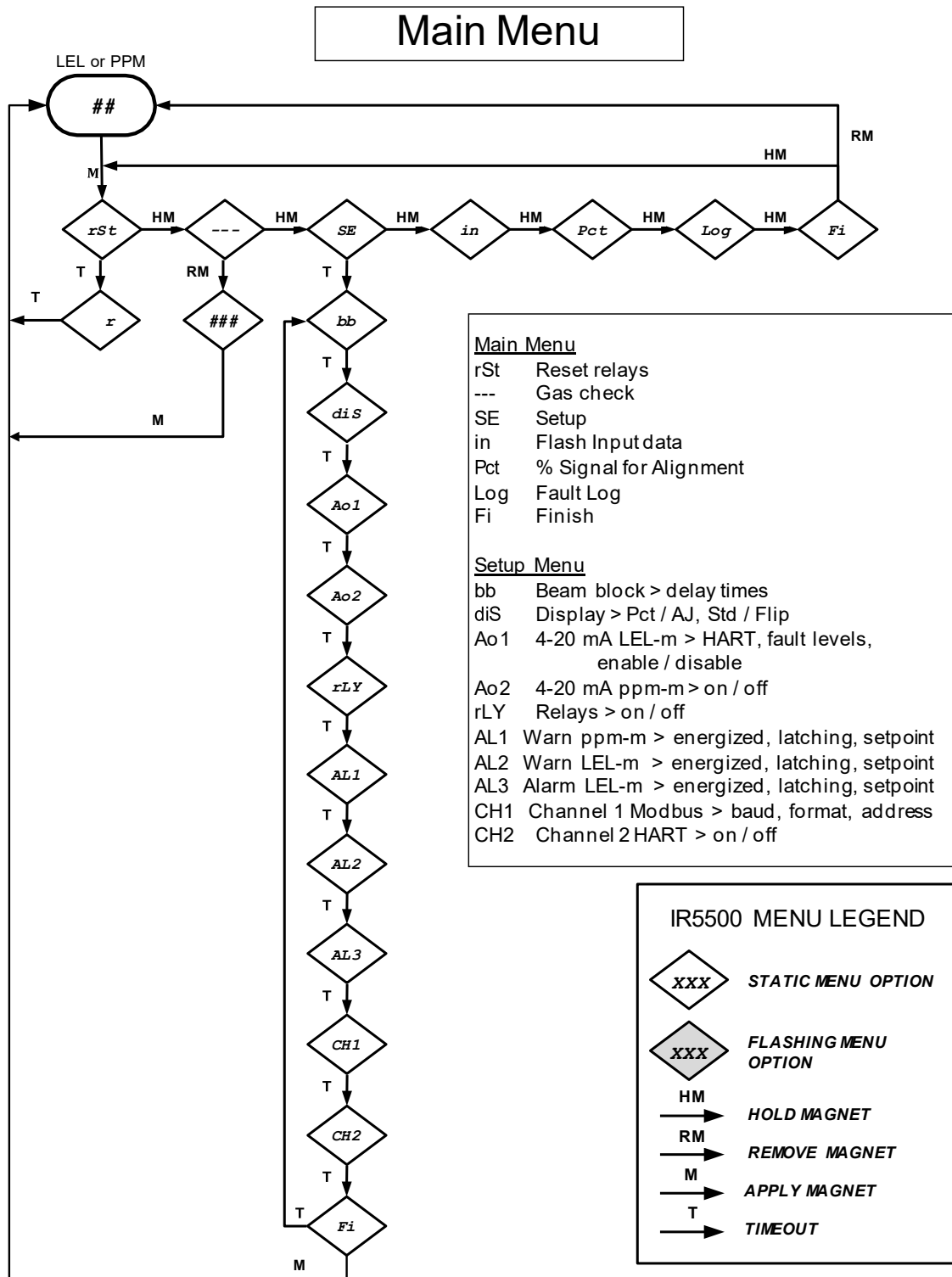

Fig. 10 IR5500 Main Menu Tree

4.2 Menu Options

The Model IR5500 allows the user to reset, test, and align the system as well as configure Receiver outputs. To access the menu, place the magnet supplied with the Model IR5500 over the General Monitors logo on the label of the Receiver for approximately five seconds. The display will cycle between the options. Remove the magnet to select an option. These options are:

“**rSt**” – Reset relays

“**---**” – Gas check

“**SE**” – Setup

“**in**” – Flash Input data

“**Pct**” – % signal for alignment

“**Log**” – Fault log and zero offset

“**Fi**” - Finish, return to normal operation

4.3 Test “---”

Apply the magnet when the flashing bars are showing and the unit enters Test Mode. While the unit is in this mode the optical faults and relays will be inhibited, the analog output will drop from 4 mA to 1.5 mA and the display will flash.

This mode allows the user to check the IR5500 response to a Test Gas Film without activating the relays and analog outputs. After verifying the response, remove the Test Gas Film. The unit will return to normal operation. If the Test Gas Film is not removed after 5 minutes, the unit will revert to a fault condition. If left in this mode for 5 minutes without a Test Gas Film, the unit will return to normal operation automatically.

To abort Test Mode before the gas has been applied, reapply the magnet and the unit will return to normal operation.

4.4 Setup “SE”

Apply the magnet when “**SE**” is showing and the unit enters Setup.

This mode allows the user to change various unit attributes. Following is the order in which the options are displayed (to change, apply magnet when the desired option is showing):

Fi - Exits the current option and goes on to next.

bb - Beam Block and IR Flash Intensity fault delay settings

Close to Low IR (F1) fault must be enabled for Beam Block output. Refer to EdF in the Analog Output menu.

- **AOd** – Analog Output delay

0, 1, 2...10, 15, 20, 25... 60 - Seconds before the F1 fault code becomes active. Ao1 level changes to bbF, and the Receiver displays fault code F1.

- **oFd – Output Fault delay**

0 to 60 - Minutes before the F3 fault is active. The Ao1 level changes from bbF to dEt, and the displayed fault code changes from F1 to F3.

- **ind – IR Input Fault delay**

0 to 60 - Minutes before the F12 fault is active. The Ao1 level changes to inF, and the Receiver displays fault code F12.

diS – Display options

- **Pct / AJ** – Display alignment signal strength displayed as percent expected (Pct) or as a logarithm of signal strength during adjustment (AJ).
- **Std / FLP** – Display standard or flipped as a mirror image, for reading via mirror when the display is close to a pipe, tank, wall, or other surface.

Default values are in red

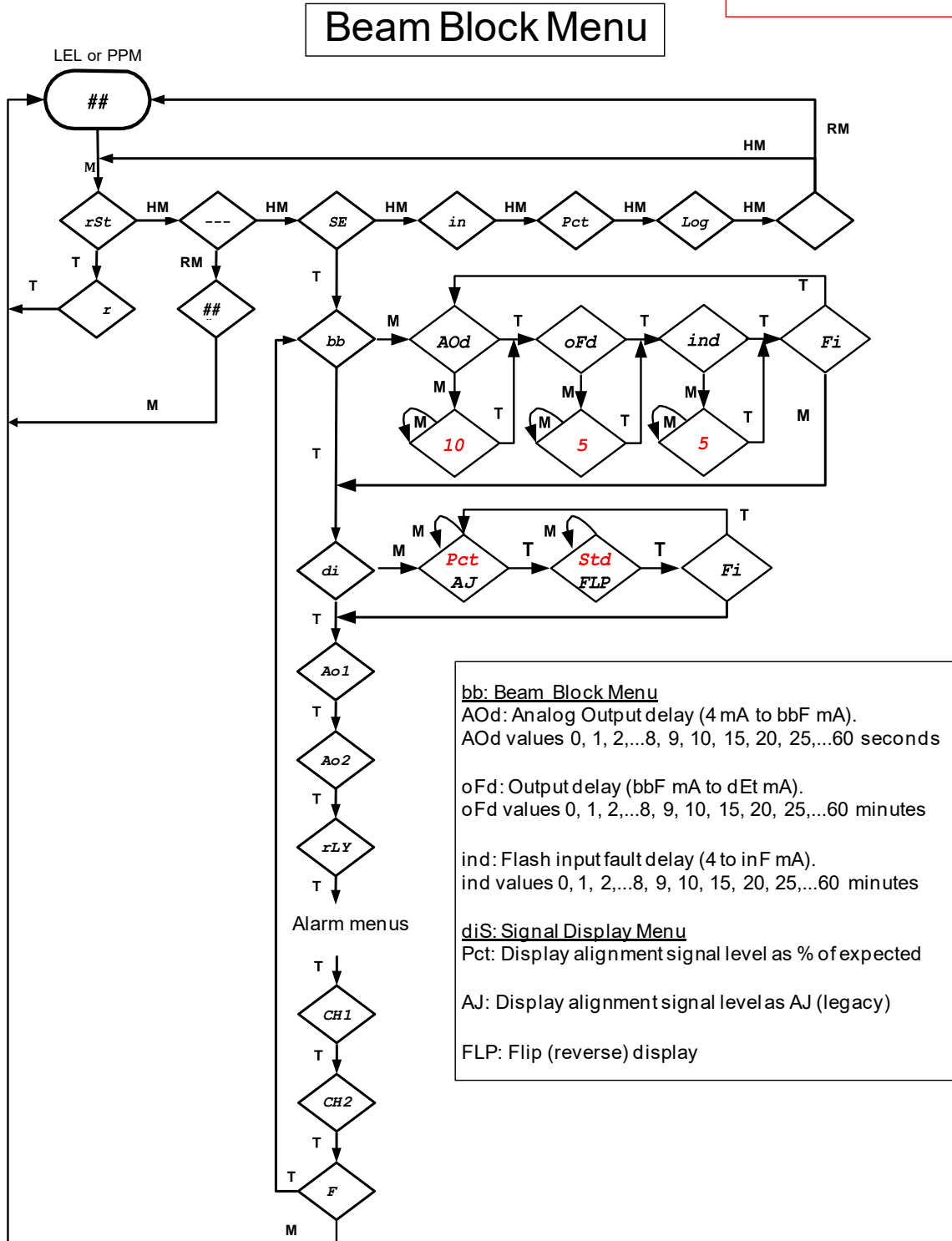

Fig. 11 IR5500 Beam Block Menu Tree

Ao1 – Apply magnet when this code is showing to alter the options for Analog Output #1 for LEL-m.

For HART 1.25 mA and Dual Modbus Receivers, the fault levels for Ao1 are adjustable.

Each fault code is in one of four fault output levels

bbF
Beam block fault
F1 Close to Low IR

dEt	ELc	inF
Detection fault	Electronics fault	IR Input fault
F0 Excessive Drift F3 Beam Block / Low IR F7 Code Checksum F8 Fault While Zeroing F9 Gas Left F13 Memory F18 Dirty Lens F20 Alignment F21 Zeroing F22 RAM	F5 Setup Menu F6 Receiver Low Supply Voltage F10 Relay Reset Short F11 Receiver Overheating F14 AO1 LEL-m Circuit F15 Receiver Heater F19 Magnet Switch F23 Hardware Revision F24 Temperature Sensor F25 AO2 ppm-m Circuit tF6 Source Low Supply Voltage tF7 Source Heater tF8 Source Overheating	F4 Flash Erratic F12 Optical Signal Variation F16 High IR

- **EdF** (Enable / disable non-critical faults)
 - 0: Enable all faults
 - 1: Disable Close to Low IR (F1)
 - 2: Disable Dirty Optics (F18)
 - 3: Disable Close to Low IR (F1) and Dirty Optics (F18)
 - 4: Disable Heater fault (F15)
 - 5: Disable Closer to Low IR (F1) and Heater fault (F15)
 - 6: Disable Dirty Optics (F18) and Heater fault (F15)
 - 7: Disable Close to Low IR (F1), Dirty Optics (F18), and Heater (F15)

If Close to Low IR (F1) is disabled, Beam Block fault output bbF is disabled.
Refer to the Ao1 menu and the Beam Block menu bb.
- **SPL** – Split-Range - on or off
 - Refer to “Split-Range Analog Output Option” in the appendix.

Std / FLP – Display standard or flipped as a mirror image, for reading via mirror when the display is close to a pipe, tank, wall, or other surface.

Ao2 - Analog #2 for ppm-m on or off (Not available if Split-Range is on)

Default values are in red

Analog Output Menu

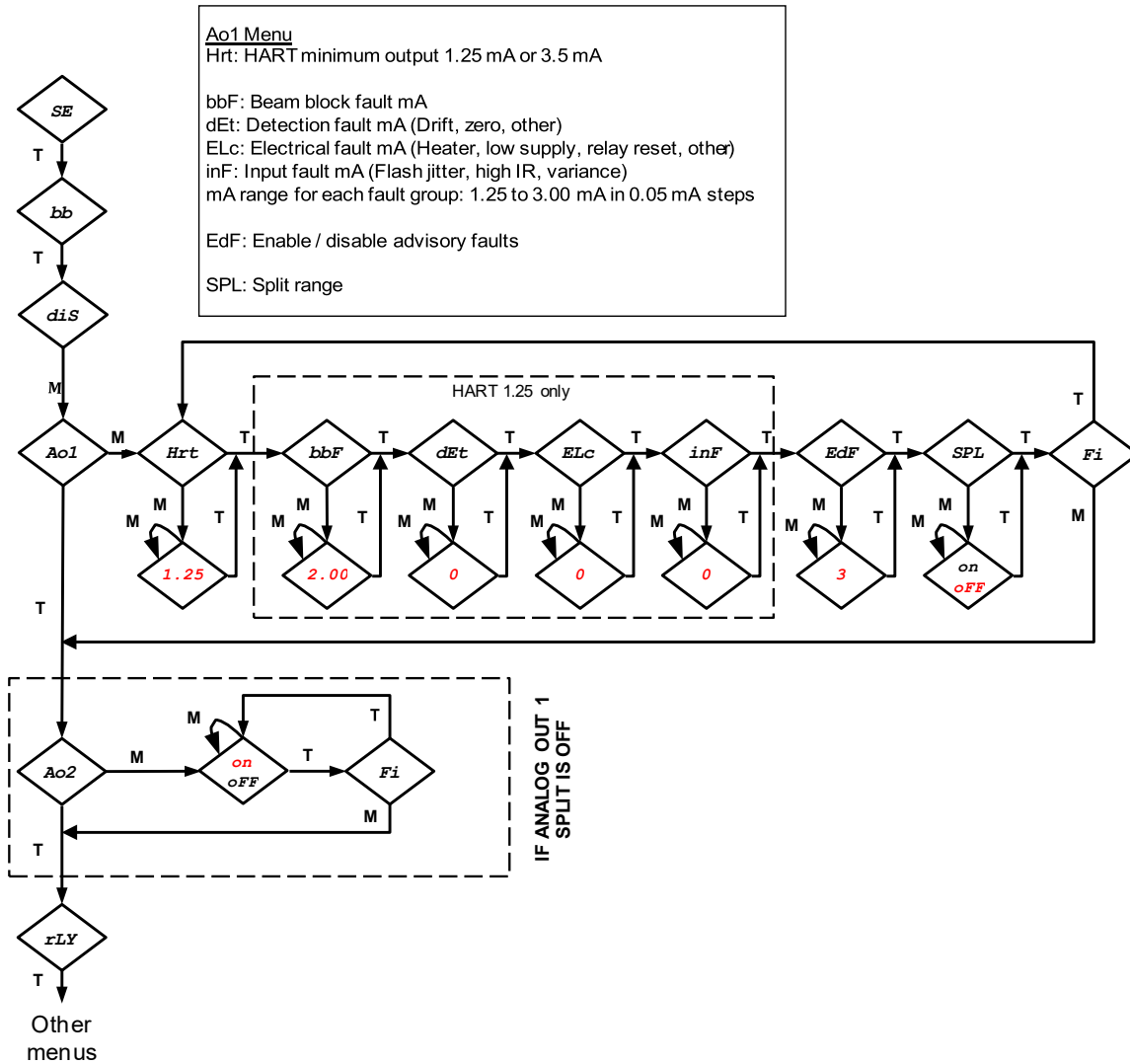

Fig. 12 IR5500 Analog Output Menu Tree

rLy – Relay

- **Password required to turn relays off: u19, ^61**

AL1 - Alarm Relay #1 (0-5,000 / 0-2,000 ppm•m)

- **En** or **dE** - Energized or De-energized.
- **LA** or **nL** - Latching or Non-Latching.
- **2000** to **4500** - Alarm level, increments by 100 or
- **800** to **1800** - Alarm level, increments by 100.

(Value increments each time magnet is applied)

(The ppm-m values are displayed in hundreds. For example, 2000 ppm-m is displayed as **20**.)

AL2 - Warn Relay #2 (0-5 / 0-1 LEL•m)

- **En** or **dE** - Energized or De-energized.
- **LA** or **nL** - Latching or Non-Latching.
- **0.5 (0.1)** to **AL3** - Alarm level, increments by 0.1.

(Value increments each time magnet is applied)

AL3 - Alarm Relay #3 (0-5 / 0-1 LEL•m)

- **En** or **dE** - Energized or De-energized.
- **LA** or **nL** - Latching or Non-Latching. If this relay is set to “nL” (non-Latching), the IR5500 must be connected to an auxiliary system which is able to provide the same function as a latching relay i.e. the alarm can only be reset manually.
- **AL2** to **4.5 (1.8)** - Alarm level, increments by 0.1.

(Value increments each time magnet is applied)

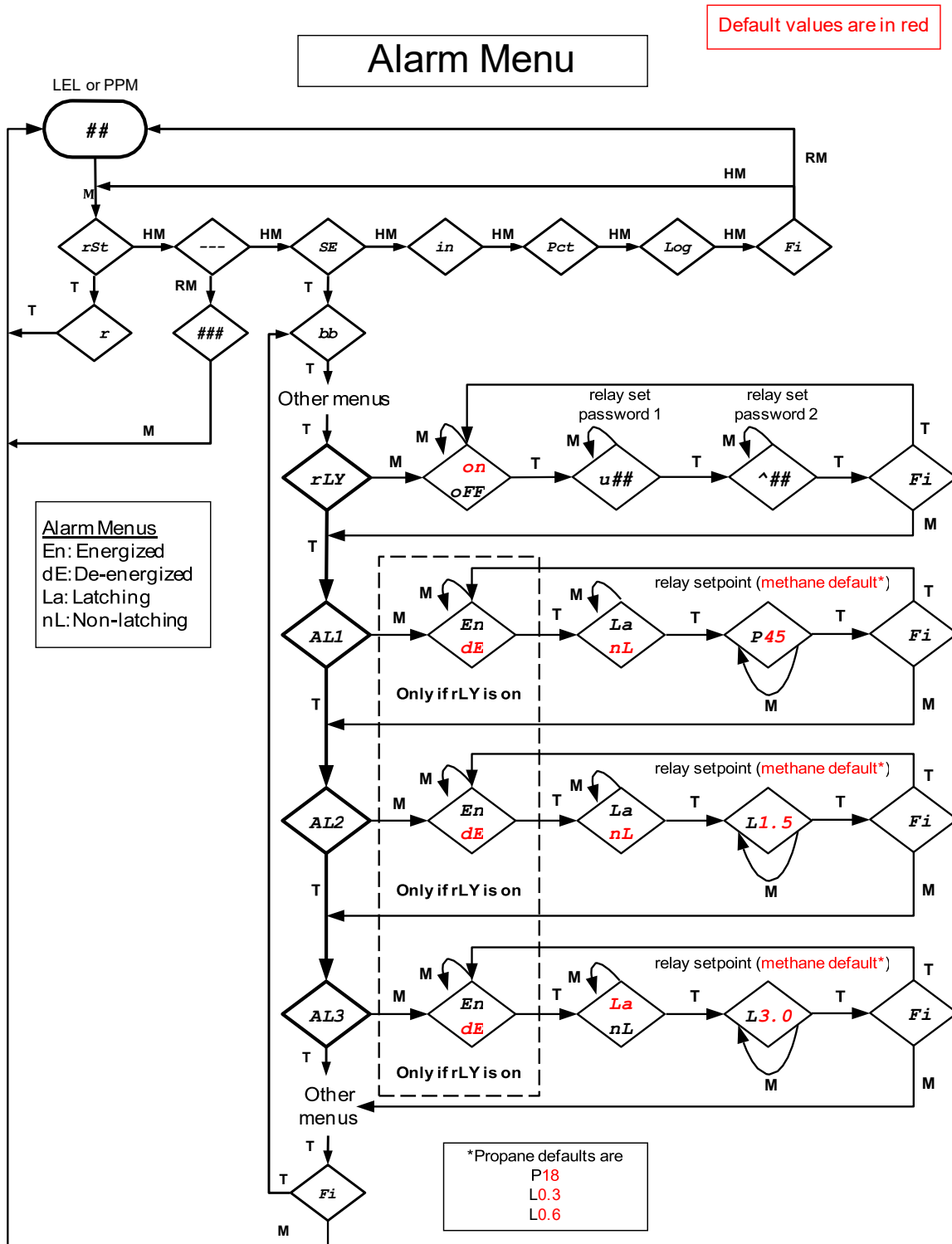

Fig. 13 IR5500 Alarm Menu Tree

CH1 – Channel 1 Modbus

- **br** – baud rate – 2.4, 4.8, 9.6, 19.2, or 38.4 kbps
- **For** – Format – 8n1, 8E1, 8o1, or 8n2 – bits, parity (none, Even, odd), stop bits
- **Add** – Address

CH2 – Channel 2 HART

HART

- **on or off**

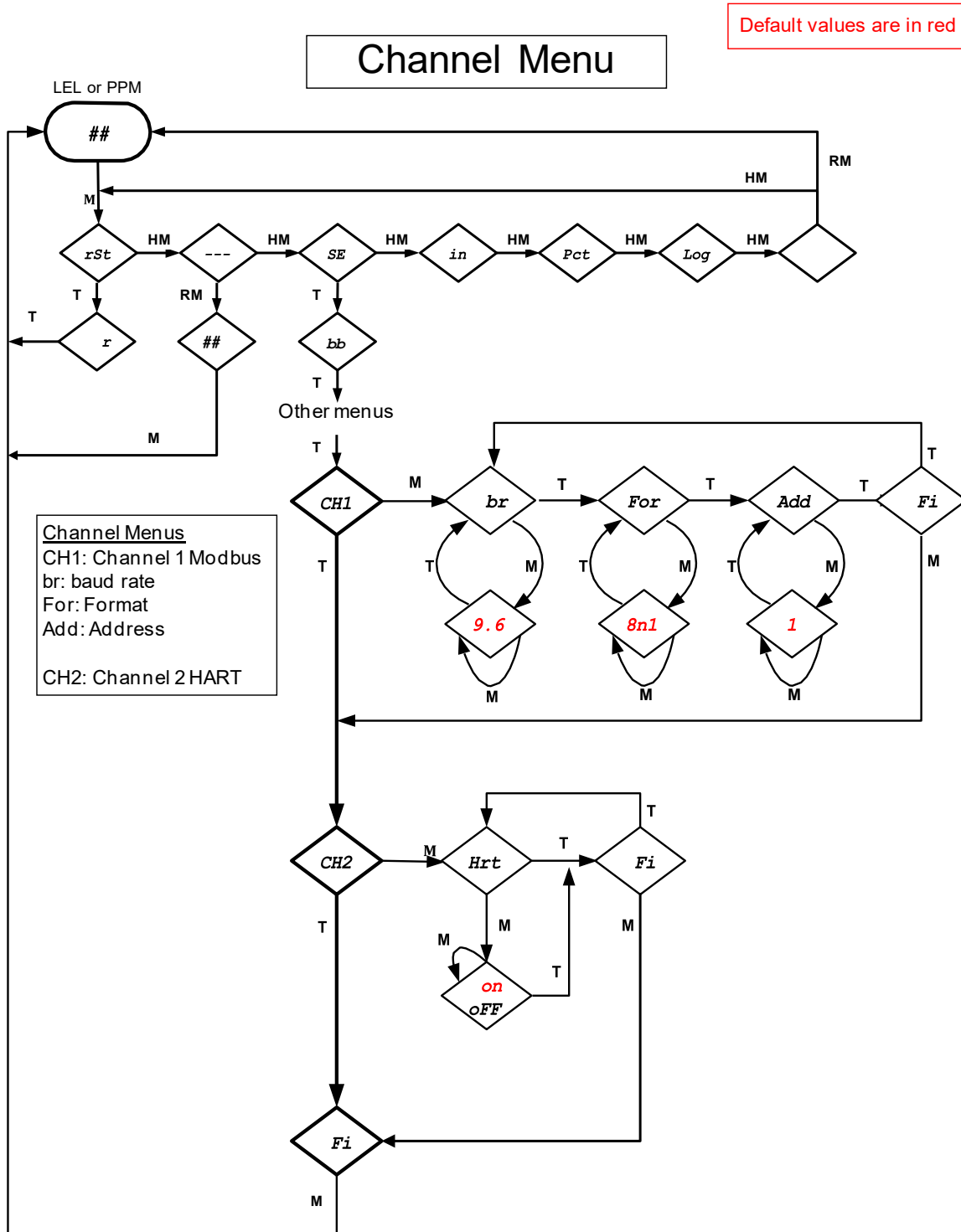

Fig. 14 IR5500 Channel Menu Tree

4.5 Flash Input “in”

The flash input data is used to diagnose issues such as poor alignment, path interference, and aging Source lamp.

The rSd is the relative standard deviation of reference flash input intensity. The rEF is the average reference flash intensity. An rSd > 60 for ind time sets fault F12. An rSd ≤ 60 resets fault F12. The rSd and rEF values are updated every 30 seconds

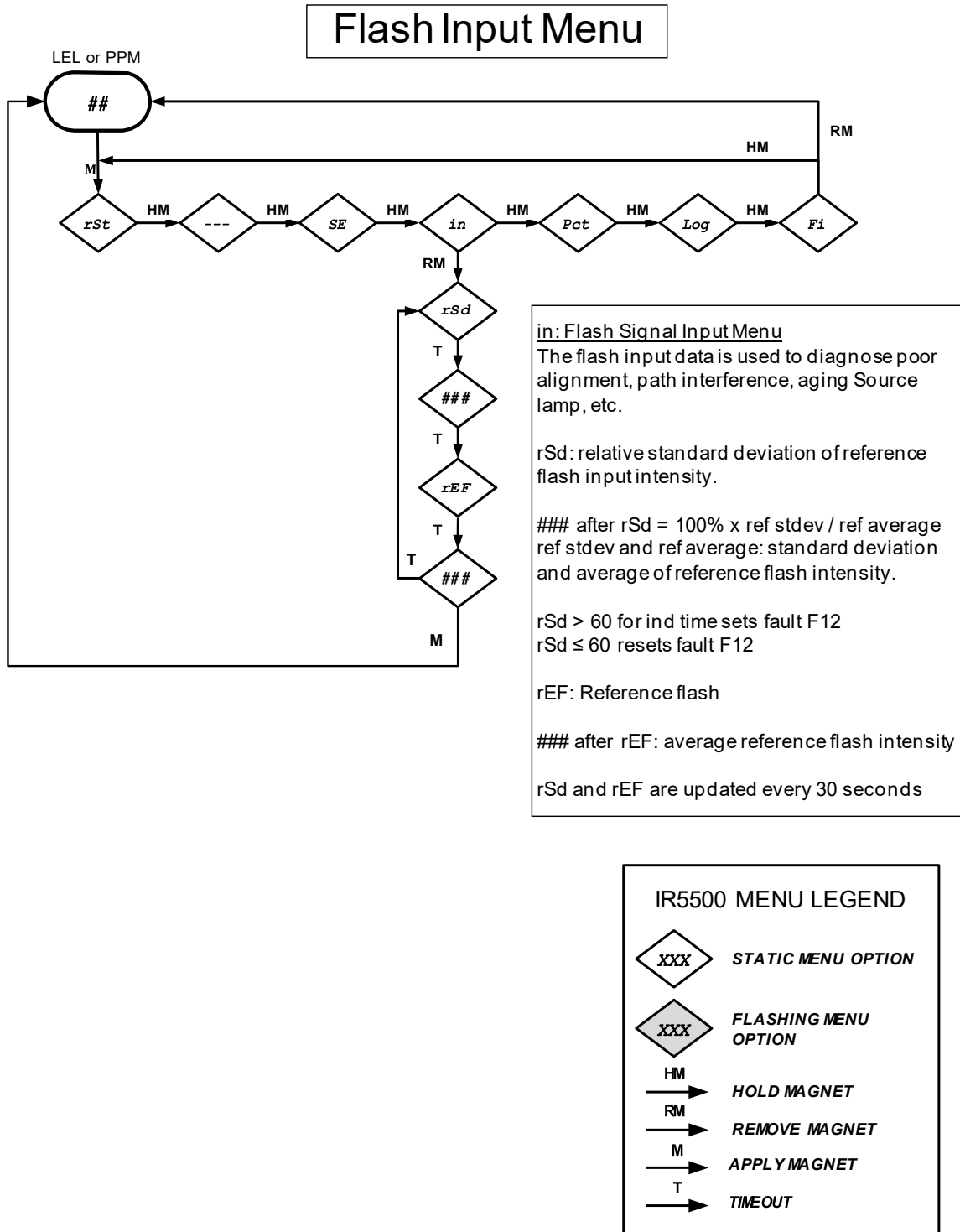

Fig. 15 IR5500 Flash Input Menu Tree

4.6 Alignment/Adjustment “Pct” or “AJ”

Pth (Path length) – Active only when the display (diS) option in the SE menu is set for IR input signal is percent of expected (Pct). The Path Length should be accurate to within $\pm 5\%$

AJ is the legacy value for signal strength. Refer to the Appendix for aligning a system using AJ.

Yd, ntr, ft – Path length units in yards, meters, or feet, where “ntr” is used for meters instead of “mtr” due to display constraints.

nAt / At – no attenuator / attenuator (5-30 meter range Receivers only).

nLF / LF – no light filter / light filter on the Source.

or **A##** – Alignment signal strength as percent expected (###) or as a logarithm of signal strength during adjustment (A##).

AC (flashing) – Alignment and zeroing in progress.

0C – Alignment and zeroing is complete.

Pct = $100\% * \text{actual signal level} / \text{typical minimum signal level}$, where typical minimum = signal mean – one standard deviation at the specified Path Length. If Pct > 150, verify that the Path Length is accurate.

Default values are in red

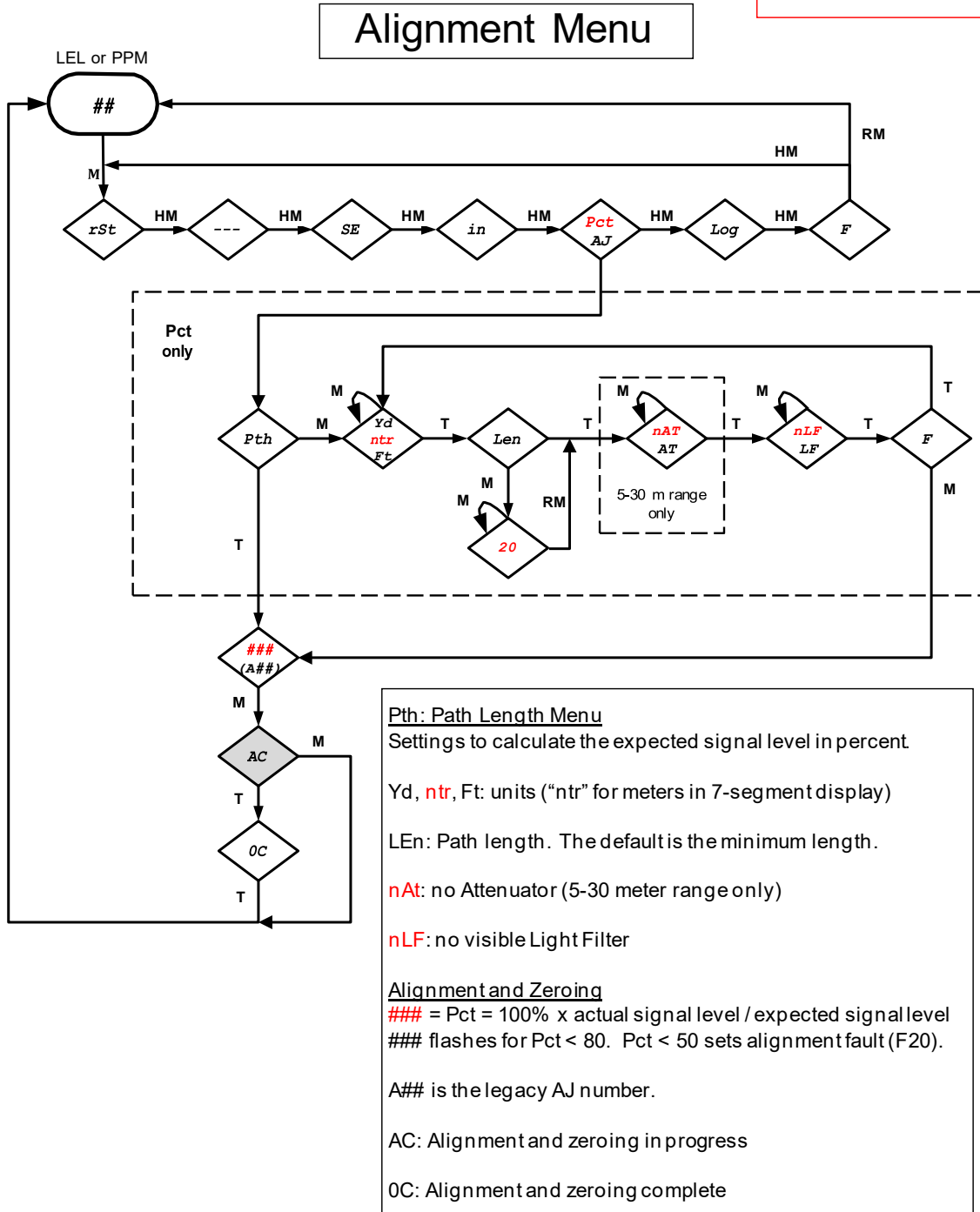

Fig. 16 IR5500 Alignment Menu Tree

4.7 Log – Fault Log and Zero

Zro – The Zero offset. If there is no offset, Zro is 100. Background gas during zeroing creates Zro > 100. Dirty optics or partial obscuration can make Zro < 100.

– Event index, 1 to 10, 1 is most recent.

ddd – runtime in days. ddd before FLt shows the current runtime.

Fxx – Fault code for the highest priority fault.

hi FF and lo FF – High and low bytes of the fault code, to indicate if there is more than one fault.

hi DD and lo DD – High and low bytes of the diagnostics code, to provide more detail on the cause of the fault.

Fault Log Menu

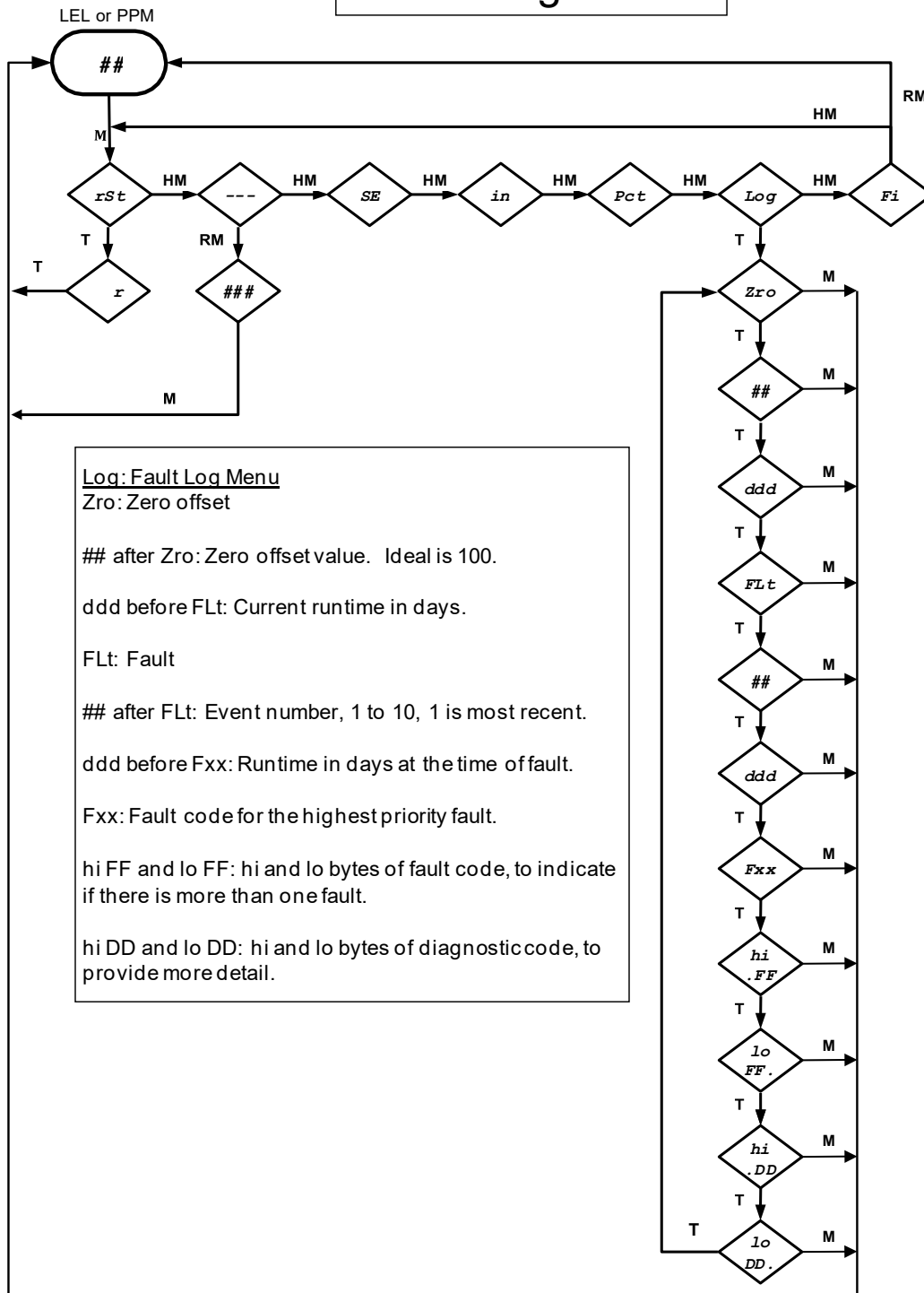

Fig. 17 IR5500 Fault Log Menu Tree

4.8 Finish “Fi”

Apply the magnet when “Fi” is showing and the unit will exit the Options Mode, save any changes that were made, and return to normal operation. This is the only way changes made in Setup Mode are saved.

4.9 Maintenance

After the Model IR5500 has been initially aligned, the unit requires little maintenance. Although calibration is not required, response should be tested from time to time using the Test Gas Films designed for the IR5500.

If the Model IR5500 is operated under dusty or dirty conditions, the windows should be cleaned periodically. This is accomplished by gently wiping them with a soft, clean cloth, which has had a commercial window cleaning solution applied. Water and ethanol are suitable solvents. The cleaning should be done in Test Gas Mode to prevent false alarms.

The estimated mean time between failures (MTBF) for the Source lamp is 4 years. Should the Source lamp need replacement, use the Lamp Replacement Kit listed in the Spare Parts section.

The Model IR5500 Gas Detector should be stored in a clean, dry area, and within the temperature and humidity ranges noted for environmental specifications in Section 8.2. Insert the red dust caps into any vacant cable entry holes while the unit is stored.

NOTE: The IR5500 will detect vapors from alcohol and other cleaning solvents.

4.10 Display and Fault Codes

The display codes during normal operation are:

- SU** Start-Up - This is displayed immediately after power is applied and lasts for approximately two minutes.
- SF** Re-Start from an optical Fault - This is displayed when an optical Fault condition has been corrected.
- 0-50** Steady Numeric Indications - This is displayed when a concentration of gas is detected in the operational mode.
- 0-50** Flashing Numeric Indications - This is displayed when a concentration of test gas is at the detector in the test gas mode.

Other codes that can appear on the display are Fault codes, which are listed in the following section.

4.11 LEL and ppm Negative Drift Faults

The ppm negative drift fault occurs when the IR5500 is zeroed with a small background gas and strong air currents dissipate the remaining gas. Under such circumstances, the ppm range current may decrease to 0 mA, prompting the detector to produce a fault.

It is unsafe to use the IR5500 when there is negative drift in the LEL range. A LEL negative drift causes both currents to go to zero and the fault relay to de-energize. The LEL negative drift may occur when the system is first installed and not yet aligned.

Negative drift on the ppm range is not a dangerous condition as with a LEL negative drift. The ppm negative drift does not put the IR5500 into a total fault. Nonetheless, it returns the ppm current to zero.

5.0 Troubleshooting

If equipment or qualified personnel required to troubleshoot are not available, it is recommended that the defective unit be returned to General Monitors for repair.



CAUTION: General Monitors' warranty will be voided if damage results from repair attempts other than routine replacement of recommended spare parts. Repairs performed by persons other than General Monitors' authorized personnel may void the warranty. Please read the warranty statement carefully. A defective IR5500 Infrared Open Path System should be returned to the factory for repair even if the warranty has expired. A complete written description of the problem should be included with all returned equipment.

CAUTION: Component level repair must be undertaken either by General Monitors' personnel, or by competent authorized service engineers. SMT PCB repair shall only be performed at a General Monitors facility. Failure to comply with this requirement will invalidate the warranty.

Be sure to inhibit or disconnect the external alarm wiring before making any check, which might send the unit into alarm.

5.1 Fault Codes

The Model IR5500 Infrared Open Path System will indicate a fault code number on the three-digit display as an aid to troubleshooting. The following list identifies the fault codes, gives a description of the fault, and indicates the corrective action that should be taken.

Fault Code	Fault Name	Fault Code	Fault Name
F0	Excess Negative Drift	F15	Receiver Heater
F1	Close to Low IR	F16	High IR
F3	Low IR	F18	Dirty Lens
F4	IR Flash Timing	F19	Magnet
F5	Setup Menu	F20	Low Alignment Signal
F6	Low Voltage Input at Receiver	F21	Zeroing
F7	Code Checksum	F22	RAM Checksum
F8	Fault during Zeroing	F23	Hardware Revision
F9	Gas Left	F24	Receiver Temperature Sensor
F10	Reset Short	F25	Analog Output for ppm-m
F11	Receiver Overheating	tF6	Low Voltage Input at Source
F12	IR Flash Intensity Variation	tF7	Source Heater
F13	NVM Checksum	tF8	Source Overheating
F14	Analog Output for LEL-m		

All faults have a 10-second delay before activating, unless otherwise noted.

During a fault, the ability of the system to detect gas depends on which fault is active. Fault groups are to highlight that gas detection is generally disabled during detection and flash input faults (dEt and inF) and enabled during electrical faults (ELc). Exceptions are noted. If both types of faults are active, the fault which prevents gas detection has priority.

Fault Code	Fault Group	Can detect gas	Fault Code	Fault Group	Can detect gas
F0	dEt	Yes	F14	ELc	No
F1	bbF	Yes*	F15	ELc	Yes
F2	dEt	No	F16	inF	No
F3	dEt	No	F18	dEt	Yes
F4	inF	No	F19	ELc	Yes
F5	ELc	Yes	F20	dEt	No
F6	ELc	Yes	F21	dEt	No
F7	dEt	No	F22	dEt	No
F8	dEt	No	F23	ELc	Yes
F9	dEt	No	F24	ELc	Yes
F10	ELc	Yes	F25	ELc	No
F11	ELc	Yes	tF6	ELc	Yes
F12	inF	No	tF7	ELc	Yes
F13	dEt	No	tF8	ELc	Yes

*The system can detect gas during F1 provided that there is sufficient flash input signal. The system cannot detect gas if no flash input is received.

5.1.1 F0 Excess Negative Drift

This fault indicates $LEL-m < -10\%$ of full scale LEL-m.

ACTION – Clean the optics. Remove any partial blockage in the beam path. Verify that the distance between the Source and Receiver is greater than the range minimum. Align the system.

5.1.2 F1 Close to Low IR

This fault indicates that either (1) IR input intensity is within 10% of the Low IR fault threshold, or (2) IR input intensity is below the Low IR fault threshold and the output fault delay time (oFd) has not yet elapsed. .

ACTION – Unit windows should be cleaned and the optical path checked for blockage. If the window is clean and the path is clear, realigning the Source and Receiver when no background gas is present should correct this fault.

5.1.3 F3 Beam Block

This fault indicates that IR input is below the Low IR fault threshold.

ACTION – The system should be aligned and the optical path should be checked for blockage or windows cleaned.

5.1.4 F4 IR Flash Timing

Flashes from the Source are erratic.

ACTION – Verify that IR is only from one Source. .

5.1.5 F5 Setup Menu

This fault indicates that the user has not exited the setup menu after 6 minutes of inactivity.

ACTION – Apply the magnet to exit the setup menu.

5.1.6 F6 Low Voltage Input at the Receiver

ACTION – Ensure the supply voltage at the Receiver is within specification..

5.1.7 F7 Code Checksum

This fault indicates a fault in device program memory.

ACTION – Cycle power. If the fault persists, contact the factory.

5.1.8 F8 Fault during Zeroing

This fault indicates that a fault occurred during zeroing.

ACTION – Repeat zeroing with no faults present.

5.1.9 F9 Gas Left

This fault indicates the unit timed out while in Gas Check Mode.

ACTION – Remove the Test Gas Film and apply the magnet to clear the fault.

5.1.10 F10 Reset Short

This fault indicates that the reset external connection is shorted to ground for more than 30 seconds.

ACTION – Remove the reset short wire from ground.

5.1.11 F11 Receiver Overheating

This fault indicates that the Receiver unit is over temperature. The IR5500 continues to detect gas but its accuracy is degraded and the long term reliability is compromised.

ACTION – Ensure that the ambient temperature for the Receiver is within specification.

5.1.12 F12 IR Flash Intensity Variation

This fault indicates that the flashing signal to the Receiver is unstable.

F12 is most often caused by inadequate alignment. Other causes are partial obscuration, interference from another Source, interference in the beam path, and mounting movement or vibration.

ACTIONS

- Re-align Source and Receiver for maximum signal level.
- Remove partial obstructions or move the system so that the beam path is clear.
- Clean optics.
- Prevent flash input from another Source by either swapping Source and Receiver or changing system orientation.
- Verify that the Source voltage supply exceeds minimum requirements.
- Ensure that mounting for the Source and Receiver is stable.
- Review the flash input fault delay time (ind) – see Section 4.4.

5.1.13 F13 Non-Volatile Memory (NVM) Checksum

This fault indicates a fault in device data memory.

ACTION – Cycle power. If the fault persists, contact the factory.

5.1.14 F14 Analog Output for LEL-m

This fault indicates that the Analog Output circuit has malfunctioned.

ACTION – Verify that AO LEL-m output wiring is correct and that the load is within specification.

5.1.15 F15 Receiver Heater

This fault indicates that the heater in the Receiver has malfunctioned.

ACTION – Verify that the heater is properly connected and cycle power. If the fault persists, contact the factory.

5.1.16 F16 High IR

IR Flash Input is saturating the Receiver. Receiver displays 'Aor'.

ACTION – Move the Source and Receiver apart, or for 5-30 meter systems only, re-install the attenuation plate.

5.1.17 F18 Dirty Lens

Gas output is between -7 % full scale LEL-m and -10 % full-scale LEL-m.

ACTION – Clean the optics, remove any partial obscuration of the beam path, and re-align the system.

5.1.18 F19 Magnet

The Receiver senses a magnet in place for more than 6 minutes.

ACTION – Remove the magnet from the Receiver. If a magnet is not in place, remove the Receiver cover and verify that the magnetic switch SW1 on the right side of the LED Display board was not damaged during wiring.

5.1.19 F20 Low Alignment Signal

The alignment signal was below 50 % of the expected value or AJ was below 20.

ACTION – For Pct, verify that the path (Pth) values in the user menu are correct. Carefully follow instructions for system alignment for maximum signal level. Verify that the beam path is clear without any obstruction. Verify that the beam path length is within the specified range for the system.

5.1.20 F21 Zeroing

The zero offset was excessive, or the IR input during zeroing was unstable.

ACTION – Verify that the optics are clean and mounting is secure for both Source and Receiver. Align units when there is no ambient gas or beam path interference, including rain, snow, sand, et cetera.

5.1.21 F22 RAM Checksum

This fault indicates a fault in device data memory.

ACTION – Cycle power. If the fault persists, contact the factory.

5.1.22 F23 Hardware Revision

The hardware revision signal is out of tolerance.

ACTION – Cycle power. If the fault persists, contact the factory.

5.1.23 F24 Receiver Temperature Sensor

The temperature sensor signal is out of range.

ACTION – Ensure that the ambient temperature is within specification. Cycle power. If the fault persists, contact the factory.

5.1.24 F25 Analog Output for ppm-m

The Analog Output circuit for ppm-m has malfunctioned.

ACTION – Verify that AO output wiring is correct and that the load is within specification.

5.1.25 tF6 Low Voltage Input at the Source

ACTION – Ensure the supply voltage at the Source is within specification

5.1.26 tF7 Source Heater

The heater in the Source has malfunctioned.

ACTION – Verify that the heater is properly connected and cycle power. If the fault persists, contact the factory.

5.1.27 tF8 Source Overheating

This fault indicates that the Source is over temperature. The IR5500 continues to detect gas but its accuracy is degraded and the long term reliability is compromised.

ACTION – Ensure that the ambient temperature for the Source is within specification.

5.2 Other Troubleshooting Tips

5.2.1 Source does not flash

- Verify whether or not the Source includes a visible light filter. A Source with a visible light filter does not display a flashing light.
- Verify that the wiring is correct and that there are no stray wire strands that could create an intermittent short.
- Verify that the voltage at the Source wiring terminal is stable and meets minimum requirements.
- If all above conditions are met and the Source does not flash, replace the lamp. Detailed instructions are in the lamp replacement kit listed in the Spare Parts section.

5.2.2 Receiver does not display startup sequence when power is applied

- Verify that the power supply is on and that it is set to 24 volts +/- 1 volt.
- Verify that the wiring is correct.
- Use a voltmeter to check the voltage at the wiring terminal, or remove the unit and check it using a different supply.

5.2.3 Receiver displays]-[during alignment

- Verify that the Source is aimed at the Receiver and that the Receiver is aimed at the source.
- Verify that the beam path from the Source to the Receiver is free of obstruction.
- On the Receiver and on the Source, with power removed from the Source, verify that the window on each unit is clean and that an attenuator is not in place.

5.2.4 Receiver displays F1 or F3 after alignment

- Verify that the Source is aimed at the Receiver and that the Receiver is aimed at the source.
- Verify that the beam path from the Source to the Receiver is free of obstruction.
- On the Receiver and on the Source, with power removed from the Source, verify that the window on each unit is clean and that an attenuator is not in place.

5.2.5 Receiver does not respond to the magnet

- Try a slightly different location for the magnet.

5.2.6 Receiver signal level number went to 0 with no "A" on the display

- Apply the magnet to resume alignment (The alignment mode times out after 30 minutes)
- Stack a second magnet onto the first.

5.2.7 Receiver displays information other than described

- Refer to the IR5500 Receiver User Menu to apply the magnet and resume alignment.

5.2.8 Source or Receiver will not move

- Verify that fine adjust screw tops are flush with the assembly surface.
- Verify that the two front mounting screws have not been tightened down.
- Verify that the nut at the bottom of the pan-tilt assembly has not been tightened down.
- Insert a large screw driver or rod between the bottom of the unit and the mounting assembly. Press on it to loosen the mounting.

6.0 Customer Support

UNITED STATES	
16782 Von Karman Avenue Unit 14 Irvine, CA 92606	Phone: +1-949-581-4464 Email: info.gm@msasafety.com
IRELAND	
Ballybrit Business Park Galway Republic of Ireland	Phone: +353-91-751175 Email: info.gmil@msasafety.com
MIDDLE EAST	
P.O. Box 54910 Dubai Airport Free Zone United Arab Emirates	Phone: +971-299-6741 Email :gmdubai.main@msasafety.com
SINGAPORE	
35 Marsiling Industrial Estate, Road 3 #04-01 Singapore 739257	Phone: +65-6350 4500 Email : msa.singapore@MSAsafety.com

Table 4 Locations

Additional locations can be found on our web site, www.MSAafety.com

7.0 Appendix

7.1 Warranty

General Monitors warrants the Model IR5500 to be free from defects in workmanship or material under normal use and service within two years from the date of shipment.

General Monitors will repair or replace without charge any such equipment found to be defective during the warranty period. Full determination of the nature of, and responsibility for, defective or damaged equipment will be made by General Monitors' personnel.

Defective or damaged equipment must be shipped to the General Monitors plant or representative from which the original shipment was made. In all cases, this warranty is limited to the cost of the equipment supplied by General Monitors. The customer will assume all liability for the misuse of this equipment by its employees, or other personnel.

All warranties are contingent upon proper use in the application for which the product was intended and do not cover products which have been modified or repaired without General Monitors' approval or which have been subjected to neglect, accident, improper installation or application, or on which the original identification marks have been removed or altered.

Except for the express warranty stated above, General Monitors disclaims all warranties with regard to the products sold, including all implied warranties of merchantability and fitness, and the express warranties stated herein are in lieu of all obligations or liabilities on the part of General Monitors for damages including, but not limited to, consequential damages arising out of, or in connection with, the performance of the product.

7.2 Specifications

7.2.1 System Specifications

Sensor Type:	Infrared
Gas Detected:	Methane or Propane
Dual Measuring Range:	<u>Methane Light Hydrocarbon Unit:</u> 0 to 5,000 ppm•m and 0 to 5 LEL•m <u>Propane Heavy Hydrocarbon Unit:</u> 0 to 2,000 ppm•m and 0 to 1 LEL•m
Response Time:	$T_{90} \leq 3$ seconds
Accuracy:	$\leq \pm 5\%$ of full scale concentration at 25°C
Repeatability:	$\leq \pm 5\%$
Linearity:	$\leq \pm 5\%$ of full scale for each scale Or $\pm 10\%$ of applied gas concentration, whichever is greater
Drift:	Short term: $\leq \pm 5\%$ of the measuring range or $\leq \pm 10\%$ of the measured value, whichever is greater. Long term: $\leq \pm 10\%$ of the measuring range or $\leq \pm 20\%$ of the measured value, whichever is greater
Hazardous Locations Classification:	<u>CSA/FM:</u> Class I, Division 1, 2 Groups B, C, D; Class II, Division 1, 2 Groups E, F, G; Class III T4 ($T_{amb} = -50^{\circ}\text{C}$ to $+65^{\circ}\text{C}$) for FM T3C ($T_{amb} = -60^{\circ}\text{C}$ to $+75^{\circ}\text{C}$) for CSA <u>ATEX/IECEX/UKCA/INMETRO:</u> II 2 G D, Ex d IIB+H ₂ T4 Gb, Ex tb IIIC T135C Db, IP66/67 ($T_{amb} = -55^{\circ}\text{C}$ to $+65^{\circ}\text{C}$) EMIEC 60079-29-4 FM10ATEX0031X, IECEX FMG 10.0011X, FM 11ATEX0013X, IECEX FMG 11.0006X, FM21UKEX0026X, NCC 13.1536X FM21UKEX0024X, NCC 12.1179X
Path Lengths:	5 - 30 m*, 20 - 100 m, 80 - 150 m * 5 m achieved with attenuator
Modes:	Set-up, test mode, alignment
Misalignment:	Meet all performance specifications with at least $\pm 0.5^{\circ}$ of misalignment
Solar Blind:	Complies with FM 6325 performance requirements
Fog Immunity:	FM 6325 performance requirement: at least 90% blockage with $\leq \pm 10\%$ mid-scale gas accuracy
Hazardous Location and Electrical Safety Temperature Range:	-60°C to $+75^{\circ}\text{C}$
Certified Performance Temperature Range:	-55°C to $+65^{\circ}\text{C}$
Warranty:	Two years
Product Compatibility:	IR4000M, MC600, TA502A, HazardWatch, DC110

7.2.2 Electrical Specification

Input Voltage:	20 to 36 VDC, 24 VDC nominal
Input Current:	Source: 0.64 A maximum at 20 VDC input voltage Receiver: 0.50 A maximum at 20 VDC input voltage; less 0.04 A with relays disabled
Supply Power:	Source: Rated 12 watts maximum at 24 VDC input Receiver: Rated 10 watts maximum at 24 VDC input
Start-up Time:	2 minutes
Warm-up Time	2 hours minimum
Relay Ratings:	8 A @ 250 VAC, 8 A @ 30 VDC resistive max.
Relay Quantity:	4 internal; Fault, Alarm, ppm·m Warn, LEL·m Warn
Relay Contact Type:	Single Pole ChangeOver (SPDT)
Analog Signal:	0 to 22 mA (700 ohms max. load)

Function	HART Not Installed	HART Low Range	HART High Range
Fault	0 mA	1.25 mA	3.5 mA
Test Gas	1.5 mA	1.5 mA	3.5 mA
Setup mode	1.5 mA	1.5 mA	3.5 mA
Beam Block	2.0 mA	2.0 mA	3.5 mA
Startup	0 mA	1.25 mA	3.5 mA
Zero reading	4.04 mA	4.04 mA	4.04 mA
0-5 LEL·m	4-20 mA	4-20 mA	4-20 mA
Split Range	4-12 mA for 0-5000 ppm·m (methane) or 0-2000 ppm·m (propane) 12-20 mA for 0-5 LEL·m (methane) or 0-1 LEL·m (propane)	4-12 mA for 0-5000 ppm·m (methane) or 0-2000 ppm·m (propane) 12-20 mA for 0-5 LEL·m (methane) or 0-1 LEL·m (propane)	4-12 mA for 0-5000 ppm·m (methane) or 0-2000 ppm·m (propane) 12-20 mA for 0-5 LEL·m (methane) or 0-1 LEL·m (propane)
Over-range	21.7 mA	21.7 mA	21.7 mA

RS-485 Output:	Modbus RTU with Block and Single Data transfer modes
Baud Rate:	2400, 4800, 9600, 19200, or 38400 BPS
HART (Optional):	Fully HART Compliant. User selectable between HART and Modbus. HART current source Rx = 120 kilo ohms, Cx = 8 nF.
RFI/EMI Protection:	EN 61000-6-4, EN 50270

7.2.3 Mechanical Specification

Length:	12.4 inches (315 mm)
Diameter:	4.5 inches (113 mm) for SS enclosure 5.3 inches (135 mm) for Nosecone
Weight:	Source: 12.20 lb (5.53 kg) Receiver: 12.34 lb (5.60 kg) Pan-Tilt Arm Assembly 329073-1: 7.62 lb (3.46 kg)
Material:	316 stainless steel for electronics enclosure

7.2.4 Environmental Specification

Operating Range:	-55°C to +65°C @ 10% to 95% RH non-condensing, 86-108 kPa non-compensated
Storage Range:	-65°C to +75°C @ 10% to 95% RH non-condensing, 86-108 kPa non-compensated
Enclosure Protection Rating:	Type 4X, IP66/67

7.2.5 Approvals

Meets the performance requirements of FM 6325, EN 60079-29-4 and IEC 60079-29-4. CSA, FM, ATEX, UKCA, IECEx, INMETRO (NCC 12.1179X, NCC 13.1536X), DNV, EAC, Japan (CML 18JPN1140X) ESM/AEQM,; HART Registered; IEC 61508 approved to SIL 3, 2 or 1.

CSA & FM Approval:

Explosion-proof for Class I, Division 1, Groups B, C, and D, Dust-ignition proof for Class II/III, Division 1 Groups E, F and G, Non-Incendive for Class I/II/III, Division 2, Groups B, C, D, E, F, G.

ATEX, IECEx & UKCA Approval:

Flameproof ‘db’ with Equipment Protection Level ‘Gb’ for Gas Group IIB + H₂, Category 2G. Dust Ignition Protection by Enclosure with level of protection ‘tb’ and Equipment Protection Level ‘Db’ for Dust Group IIIC, Category 2D.

7.2.6 Cable Requirements

It is the responsibility of the facilities engineer to comply with all regulatory, legal, and safety issues concerning appropriate wiring for the facility.

The sample calculations are for reference only. Customers must derive the distance from supply to device based on cable specifications, expected maximum ambient temperature and cable temperature rise, estimated connection losses, allowances for error in distance measurement, and other variables particular to the customer installation.

Sample Calculations for Power Cable

V_{supply} = 24 VDC, V_{device} = 20 VDC, I_{Receiver_max} = 0.50 A, cable resistance per meter = 9.00 ohms per meter at maximum ambient temperature for 2.5 mm² cable.

Maximum distance from supply to Receiver = (1/2) x (V_{supply} – V_{device}) / (I_{device_max} x cable resistance per meter)

Maximum distance = (1/2) x (24 – 20) / (0.50 x 9.00 / 1000) = 444 meters

Sample maximum distances from supply to device

Terminal Type	Push	Screw	Push	Screw
Max Wire Size	16 AWG	14 AWG	1.5 mm ²	2.5 mm ²
Typical Resistance	5.00 ohms / 1000 ft	3.00 ohms / 1000 ft	16.0 ohms / 1000 m	9.00 ohms / 1000 m
Source	625 feet	1040 feet	195 meters	347 meters
Receiver	800 feet	1330 feet	250 meters	444 meters

Table 5 Distances from Power Supply to Source and Receiver

Sample Calculations for Analog Output Cable

Maximum load is 700 ohms. If an external device has an input impedance of 600 ohms, the cable resistance must not exceed 100 ohms, where maximum load = device load + cable resistance. For 16 AWG cable with resistance of 5 ohms / 1000 feet, the maximum distance from IR5500 and AO device is $((100 / 5) / 2) \times 1000$ feet = 10,000 feet.

AWG	Ohms/1000 ft	Feet	Meters
#20	11	4,550	1,390
#18	7	7,140	2,180
#16	5	10,000	3,050

Table 6 Distances from Receiver to Analog Output Load

7.3 Spare Parts and Accessories

To order spare parts or accessories, please contact your nearest General Monitors Representative or General Monitors directly and give the following information:

- Configuration Number
- Description
- Quantity

7.3.1 Spare Parts

329071-1	Pan-Tilt Base Assembly
329073-1	Pan-Tilt Arm Assembly
329123-1	Basic Mounting Arm Assembly (No longer available)
329083-1	Methane Test Gas Film Kit
329084-1	Propane Test Gas Film Kit
329113-1	Attenuator
329314-1	Source Stack Kit
954-021	5 mm T-handle hex key. Used for instrument-mounting screws and cover-locking screw.

Recommended Spare Parts for one (1) year:

31037-1	Double Magnet Assembly
---------	------------------------

7.3.2 Accessories

329136-1	Pan Adjustment Tool
329071-1	Pan-Tilt Base Assembly
329073-1	Pan-Tilt Arm Assembly
329123-1	Basic Mounting Arm Assembly (No longer available)
329082-1	Long Range Alignment Kit (includes scope)
329120	Instruction Sheet Arm Mounting

7.4 Engineering Documentation

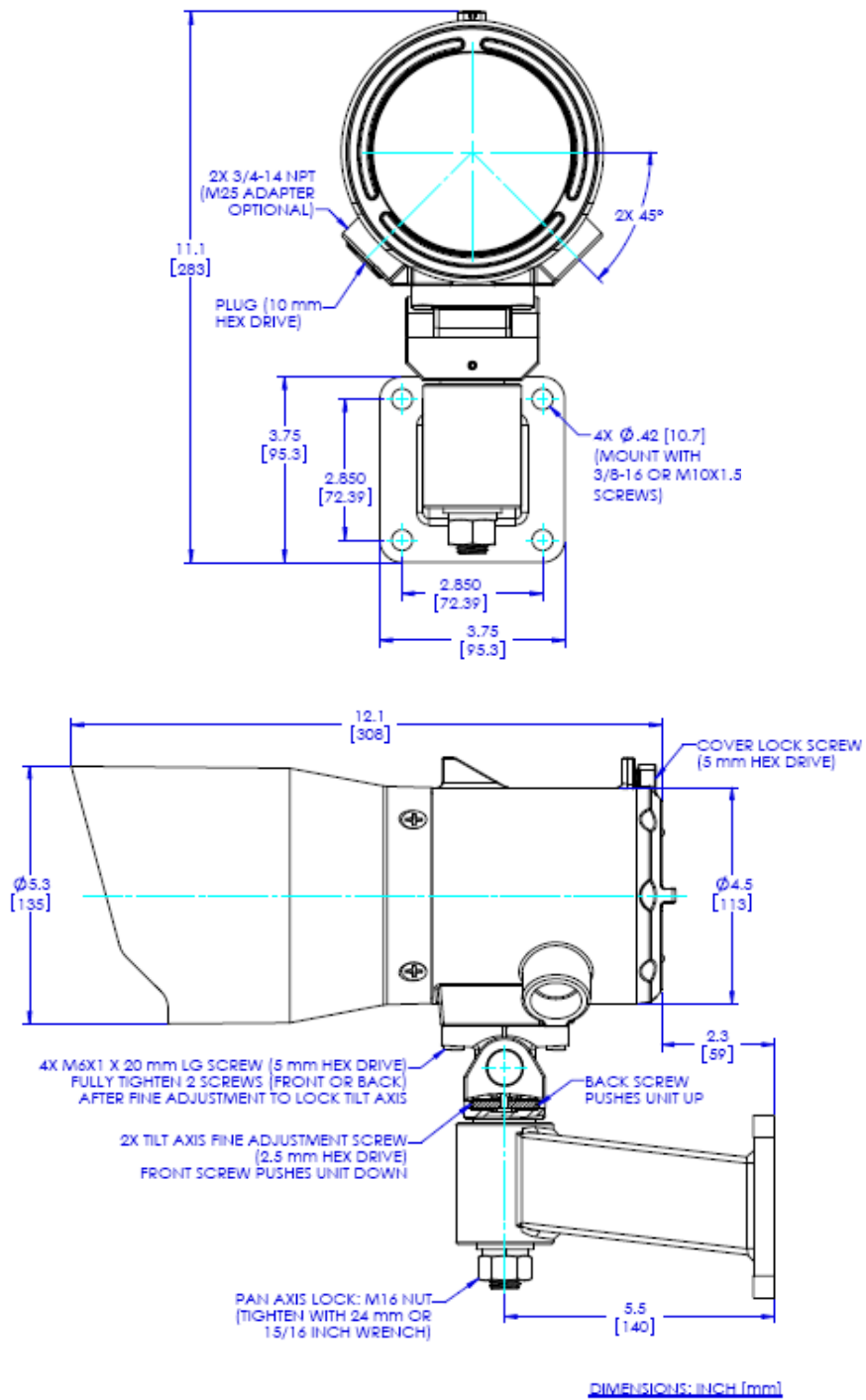

Fig. 18 Outline Drawing

8.0 Appendix A

8.1 Split-Range Analog Output Option

NOTE: This section is intended to be read and understood by a systems integration engineer. It is not necessary to understand this in order to safely use the Model IR5500 gas detector. The split-range analog output option is turned off by default and should be left off unless you are certain the control room PLC is properly configured.

If the split-range mode is turned on and the PLC is not set to calculate the analog output this way, the system will fail-to-safe because the analog is interpreted as representing a higher concentration than is present. This may cause the PLC to falsely indicate alarms.

The IR5500 can be set through the SE menu to operate in split-range analog output mode. This mode gives the advantages of very high sensitivity of the ppm·m range and the full range detection of the LEL·m scale. The analog output range from 4 to 20 mA is split so that values from 4 to 12 mA represent 0 – 5,000 ppm·m and values from 12 to 20 mA represent 0 – 5.0 LEL·m.

For the heavy hydrocarbon version of the Model IR5500 detector the ranges are 4 to 12 mA represent 0 – 2,000 ppm·m and values from 12 to 20 mA represent 0 – 1 LEL·m.

This mode is intended for use with a PLC which will convert the analog current back to both ppm·m and LEL·m readings.

The conversion equations for the PLC are:

$$\text{ppm}\cdot\text{m \% F.S.} = (\text{Analog Output} - 4.00) / 0.08$$

$$\text{LEL}\cdot\text{m \% F.S.} = (\text{Analog Output} - 12.0) / 0.08$$

where Analog Output is the current measured by the PLC in units of mA.

To display the value in ppm·m or LEL·m the following conversion should be used:

Methane detectors
$\text{ppm}\cdot\text{m} = \text{ppm}\cdot\text{m \% F.S.} * 50$
$\text{LEL}\cdot\text{m} = \text{LEL}\cdot\text{m \% F.S.} / 20$

Propane detectors
$\text{ppm}\cdot\text{m} = \text{ppm}\cdot\text{m \% F.S.} * 20$
$\text{LEL}\cdot\text{m} = \text{LEL}\cdot\text{m \% F.S.} / 100$

8.2 Alignment Using Legacy AJ Value

To change the alignment signal strength indication from Pct to AJ, apply the magnet over the GM logo on the Receiver cover until St appears. When SE appears, remove the magnet. Apply the magnet when diS appears. When Pct appears, apply the magnet until AJ appears. Remove the magnet. Apply the magnet when Fi appears. The display will cycle through more menu choices. When Fi appears again, apply the magnet to exit the setup menu. For a diagram of the menu choices, refer to the User Menu in the Operation section.

During alignment, verify that the AJ level is comparable to typical values listed below. For 80-150 meter configuration, add 50 meters to the range.

Range	20 m	30 m	40 m	50 m	60 m	70 m	80 m	90 m	100 m	
AJ value	72 to 67		65 to 60	59 to 54	53 to 48	49 to 43	45 to 38	43 to 35	39 to 32	35 to 30

Table 7 Typical AJ Signal Level Values



ADDENDUM

This product may contain hazardous and/or toxic substances.

EU Member states shall dispose according to WEEE regulations. For further WEEE disposal information please visit: www.MSAafety.com

All other countries or states: please dispose of in accordance with existing federal, state and local environmental control regulations.

Technical Index

30878-2 xiv, 18

329083 xiv, 18, 52

329084 xiv, 18, 52

4-20 mA signal 7

Accuracy 49

AJ xiii, xiv, 17, 18, 22, 32, 34, 46, 55

Analog Signal 50

Approvals 51

AWG x, 15, 52

Baud Rate 50

conduit seal vii, 11

Display Sequence on Power Up xi, 16

Drift 39, 49

Fog Immunity 49

HART (Optional) 50

heater xi, 17

Input Voltage 50

IP66/IP67 2

IR5500 Menus 20

Linearity 49

Lithium grease vi

Misalignment 49

Modes 49

NEC 500-3d or Canadian Electrical Code Handbook vii, 11

Operating Range 51

Output Options 22

path length is less than 20 meters 8

Performance Temperature 49

Product Compatibility 49

Relay Ratings 50

resolution xi, 17

Response Time 49

RFI/EMI Protection 50

RS-485 Output 50

Safety temperature range 49

Spare Parts and Accessories 52

Split-Range analog output option 54

Start-up Time 50

Storage Range 51

stripping length viii

Supply Power 50

Test Gas Film xiv, 3, 4, 22, 42, 52

Type 4X 2, 51

Water or ethanol 38