

User Instructions
ALTAIR io DOCK
Automated Gas Test System



Order No.:10220657/05

Print Spec: 10000005389 (EO)

CR:800000073446

 **WARNING!**

These instructions must be provided to users before use of the product and retained for ready reference by the user. Read this manual carefully before using or maintaining the device. The device will perform as designed only if it is used and maintained in accordance with the manufacturer's instructions. Otherwise, it could fail to perform as designed, and persons who rely on this device could sustain serious injury or death.

The warranties made by MSA with respect to the product are voided if the product is not installed and used in accordance with the instructions in this manual. Please protect yourself and your employees by following the instructions.

Please read and observe the WARNINGS and CAUTIONS inside. For additional information relative to use or repair, call 1-800-MSA-2222 during regular working hours.

MSA is a registered trademark of MSA Technology, LLC in the US, Europe and other Countries. For all other trademarks visit <https://us.msasafety.com/Trademarks>.

In these instructions, the term Test Stand refers also to the ALTAIR io 4 DOCK Test Stand, unless otherwise specified or referring to another version



The Safety Company

1000 Cranberry Woods Drive
Cranberry Township, PA 16066
USA
Phone 1-800-MSA-2222
Fax 1-800-967-0398

For your local MSA contacts, please go to our website www.MSAsafety.com

Contents

| | | |
|----------|--|-----------|
| 1 | Safety Notices | 4 |
| 1.1 | Liability | 4 |
| 2 | Welcome to the ALTAIR io DOCK | 4 |
| 2.1 | Grid Introduction | 5 |
| 3 | Getting Started | 6 |
| 3.1 | General Overview | 6 |
| 3.2 | In the Box | 7 |
| 3.3 | Bank Overview | 8 |
| 3.4 | Installation | 9 |
| 3.5 | Commissioning | 18 |
| 3.6 | Basic Operation | 18 |
| 4 | Features | 24 |
| 4.1 | Connection to Grid | 24 |
| 4.2 | Test Modes | 24 |
| 4.3 | Configuration | 25 |
| 4.4 | Bank Status | 25 |
| 4.5 | Automatic Gas Cylinder Recognition | 27 |
| 4.6 | Gas Cylinder Manual Configuration | 27 |
| 5 | Device Care | 27 |
| 5.1 | Maintenance | 27 |
| 5.1.1 | Cleaning | 27 |
| 5.1.2 | Fresh Air Filter Replacement | 28 |
| 5.1.4 | Replacing the Light Band - Cylinder Holder | 30 |
| 5.2 | Troubleshooting | 30 |
| 6 | Learn More | 32 |
| 6.1 | Disposal and Recycling | 32 |
| 6.2 | Replacement Parts | 32 |
| 6.3 | Warranty | 32 |
| 6.4 | China RoHS Requirement | 34 |

1 Safety Notices

1.1 Liability

MSA accepts no liability in cases where the device has been misused, used inappropriately or not used as intended. MSA accepts no liability in cases where damage or injury is caused by wear and tear, neglect or failure to carry out inspection and maintenance procedures. The selection and use of the device are the exclusive responsibility of the employer and/or individual operator. Warranties and guarantees made by MSA with respect to the device are voided, if it is not used, serviced or maintained in accordance with the instructions in this manual.

1.1.1 Before You Start

Before getting started with the ALTAIR io DOCK, there are several things to know.

The ALTAIR io DOCK is not compatible with the GALAXY® GX2 Automated Test System.

WARNING!

- Do NOT drop the gas cylinder or attempt to remove the gas cylinder valve. An unsecured gas cylinder can become an airborne projectile under its own pressure.
- Use, inspect and maintain gas cylinders in accordance with the gas cylinder manufacturer's instructions, including all warnings and cautions.
- Do not use silicone-type lubricants in assembling the ALTAIR io DOCK and do not allow silicone vapors to be drawn into the flow system while in operation. Silicone can desensitize the combustible gas sensor, thereby giving erroneously low readings.
- Use the ALTAIR io DOCK only in non-hazardous environments free of toxic gases and combustible concentrations of gases and vapors.
- Remove the gas cylinder from service if it shows signs of damage.
- Use only genuine MSA replacement parts when performing any maintenance procedures on the ALTAIR io DOCK. Substitution of components can seriously impair performance.
- Refer to the applicable gas device(s) user guide for proper set-up and operation. Follow all local regulations and internal requirements relating to both the ALTAIR io DOCK and the ALTAIR io device with which it is used.
- Using an incorrect span value can seriously impair the ALTAIR io device's ability to warn the user of dangerous conditions. The gas device could fail to perform as designed and the persons who rely on this product for their safety could sustain severe personal injury or loss of life.
- Using an incorrect alarm setting can seriously impair the gas detector's ability to warn the user of dangerous conditions. Extreme caution must be used when changing alarm levels. Ensure alarm changes are properly set prior to instrument use.
- Proper setup of non-RFID tagged gas cylinders is critical. Accurate calibration may not occur if improper cylinder values are entered. The user must also confirm the cylinder gas concentration is compatible with the respective devices that are to be calibrated. If improper cylinder values are entered, the gas device could fail to perform as designed and persons who rely on this product for their safety could sustain severe personal injury or loss of life.

Failure to follow these warnings can result in serious personal injury or death.

2 Welcome to the ALTAIR io DOCK

The ALTAIR io DOCK is a rugged automated test system that simplifies bump testing and calibration via its plug & play design. It's modular, so you can create one bank that includes up to 10 test stands and 3 gas cylinder holders. This system is used exclusively with the ALTAIR io family of devices.

Simply place the ALTAIR io device into the cradle and let the automated test system do the work. It tells the ALTAIR io DOCK which test it needs to run and starts it automatically. Once complete, the ALTAIR io DOCK indicates the test results, allowing the user to interpret the results. The ALTAIR io DOCK also leverages the ALTAIR io devices' cellular connection to communicate test results and ALTAIR io DOCK status to your Grid account.

2.1 Grid Introduction

Grid is a cloud-based industrial safety software platform. Every ALTAIR io DOCK can be added to your Grid account. By doing so, you're able to manage your ALTAIR io DOCK and access Grid services such as real-time bank status, calibration gas replenishment, and calibration gas expiration notices.

3 Getting Started

3.1 General Overview

3.1.1 Grid Mobile App

The Dock was designed to be deeply integrated with your Grid account which can be accessed through a browser, or the Google Play / Apple App Store mobile apps. Through the Grid mobile app, you can intuitively commission and configure the Dock to register and add it to your account.

The ALTAIR io DOCK is modular in design and comprised of Test Stands and Cylinder Holders, which connect to create a Bank.

3.1.2 Test Stand

Each Test Stand can accommodate a single device at a time, and up to 10 test stands can be in a single bank. The primary function of the Test Stand is to conduct bump tests and calibrations. The ALTAIR io 4 and ALTAIR io 6 each utilize a different model of test stand. However the io 4 and io 6 versions can both be connected to the same bank.

3.1.3 Cylinder Holder

Each Cylinder Holder can accommodate a single gas cylinder, and up to three Cylinder Holders can be in a single Bank. Every Cylinder Holder is equipped with an RFID reader that works with MSA calibration gas containing an RFID tag. This completely automates cylinder recognition and ensures that gas expiration has not been reached. Alternatively, non-MSA gas can be purchased without RFID tags, but these gas cylinders require additional manual setup.

3.1.4 Bank

A bank is created through the connection of Cylinder Holders and Test Stands. Up to three Cylinder Holders and up to ten Test Stands can be used in a single Bank. Test Stand(s) must be assembled sequentially to the right of the first stand. Cylinder Holder(s) must be installed to the left of the first Test Stand.

Special conditions for use with reactive gases must be adhered to, these are described in \3.6.3 Special Conditions for Use with Reactive Gases.

WARNING!

When configuring names for multiple Banks, a unique name for each Bank is required. Duplicate Bank names can cause inadvertent cylinder configurations or calibration modes on the incorrect Bank, resulting in incorrect calibration and erroneous gas detector readings.

Failure to follow this warning can result in serious personal injury or death.

3.2 In the Box

Test Stand

- Quick Start Guide
- Test Stand (including barbed gas plugs, barbed connectors, and fresh air filter)
- Power Supply
- Power Cord Kit (USA, EU, Australia, and UK plug heads)
- Spare Parts Kit (gas tubing barbs and plugs)
 - 1 - Bag with label (holds contents)
 - 4 - Adhesive Bumpers for Base
 - 5 - Plugs for Banking Interface
 - 5 - Barbed Connectors for Banking Interface
 - 1 - O-ring for Cylinder Holder
 - 3 - Banking Screws

Cylinder Holder

- Quick Start Guide
- Cylinder Holder

Power Supply

The Test Stand supplies power to the attached Cylinder Holders. The Test Stands are powered individually by one of the following methods:

- Power Module: 100 - 240 VAC
- Input power requirements: 47 - 63 Hz

Several different prong types are available for world-wide AC sockets.

NOTICE

Use of a power supply not specified by MSA will void the device warranty and could cause damage to the Dock.

3.3 Bank Overview

ALTAIR io DOCK Test Stands

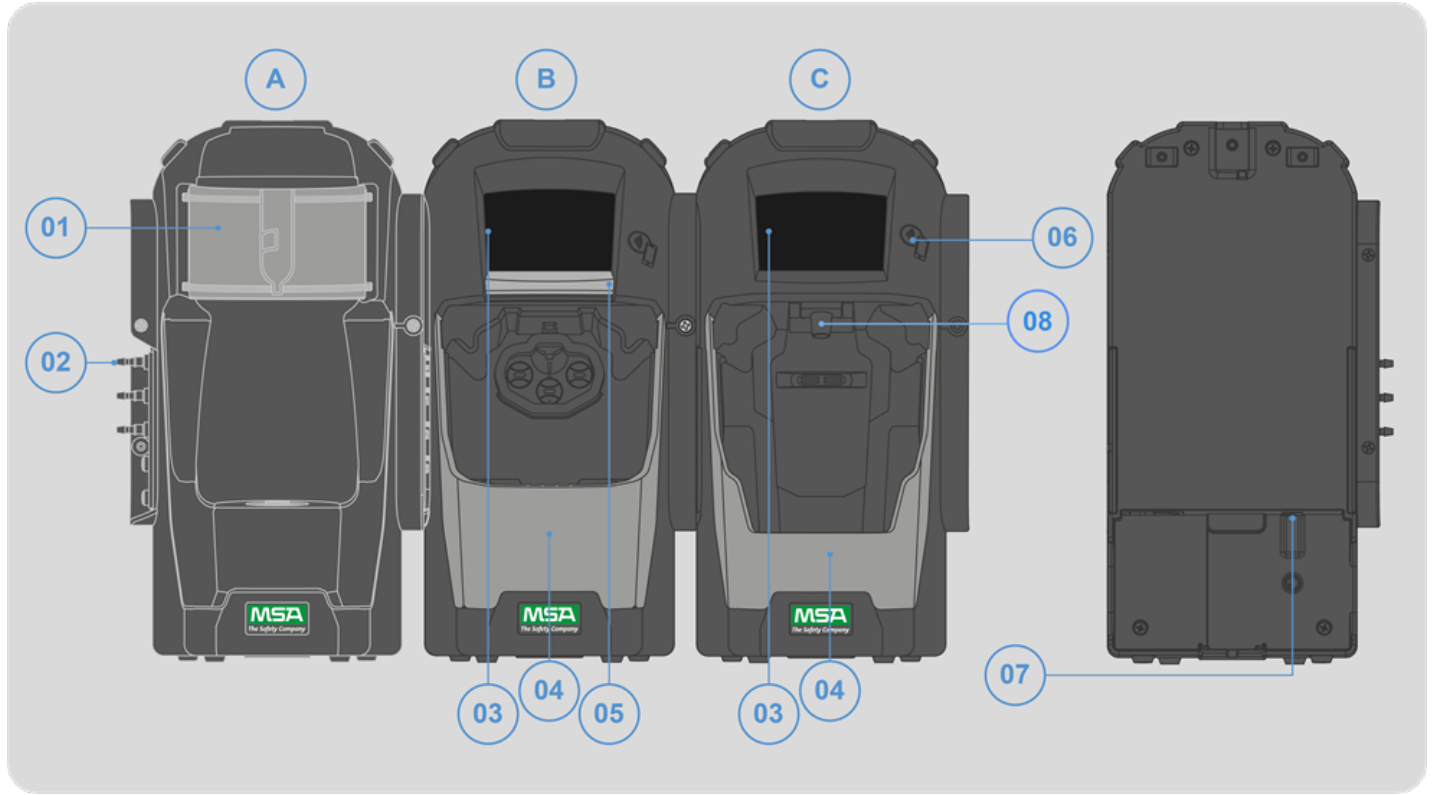

| | | | |
|----|------------------------------|----|-------------------------|
| A | Cylinder Holder | 04 | Test Stand Light Shield |
| B | ALTAIR io 4 DOCK Test Stand | 05 | Eject Button |
| C | ALTAIR io 6 DOCK Test Stand | 06 | Tap or Pair Location |
| 01 | Cylinder Holder Light Shield | 07 | Power Cable Port |
| 02 | Barbed Connectors | 08 | Barb Adapter |
| 03 | Test Stand Display | | |

3.4 Installation

Up to ten Test Stands and three Cylinder Holders can be installed in a Dock bank. Test Stands must be assembled sequentially to the right of the first stand. Cylinder Holder(s) must be installed to the left of the first Test Stand.

Tools Needed:

- Phillips head (cross-head) screwdriver

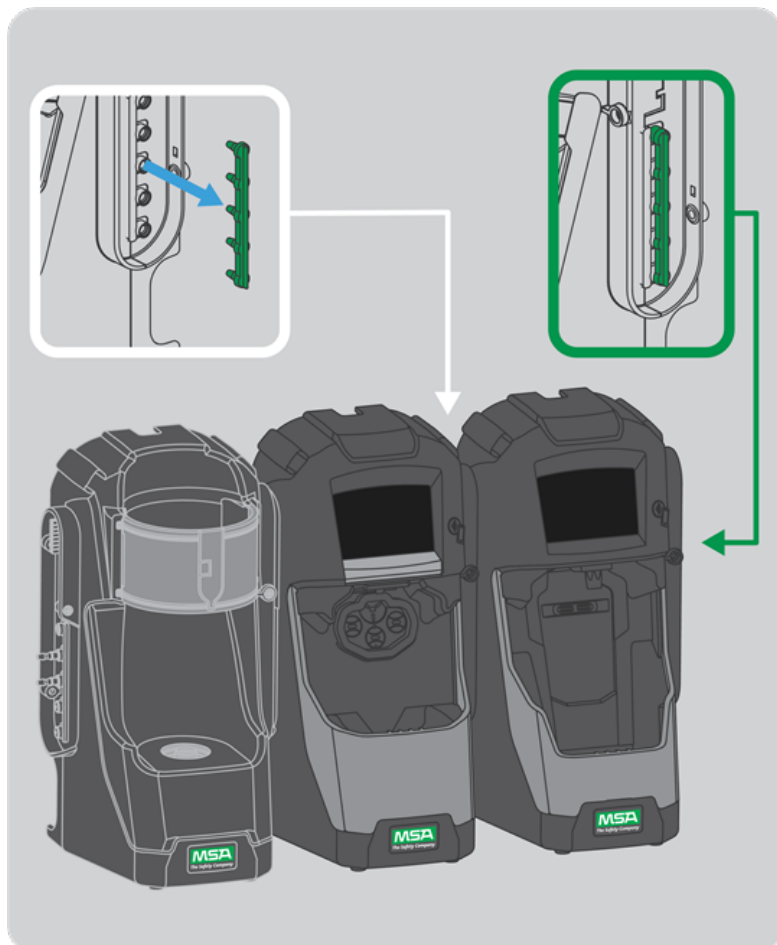

1. On the left-hand side of the first Test Stand, ensure all four barb fittings are in place and straightened before connecting a Cylinder Holder.
2. Remove the three supplied screws from the left side flange of the Test Stand and set aside for future use.

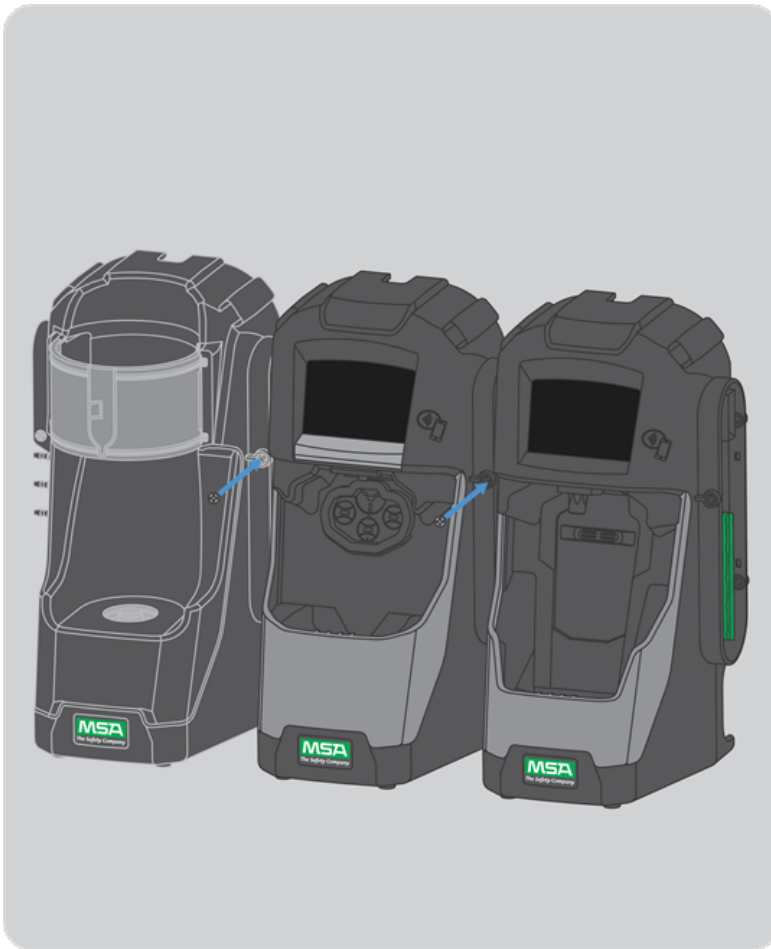

3. With the first Cylinder Holder on the left and the first Test Stand on the right, align the barbed connectors and fittings, and firmly push the two units together until the screw holes in the flange align.

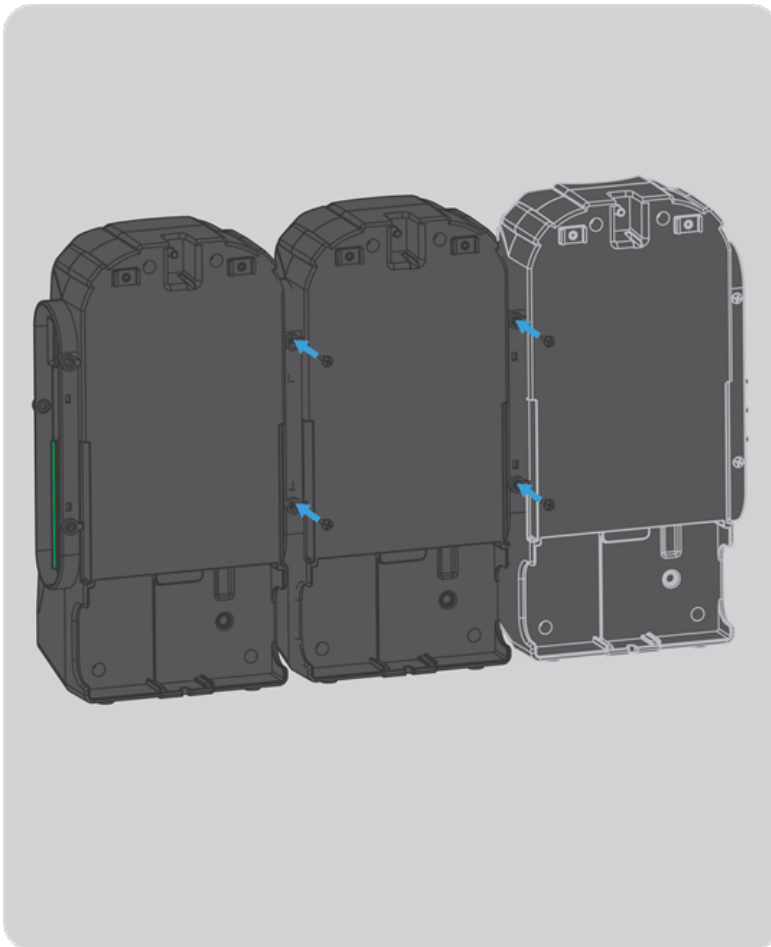

4. Insert one of the supplied screws into the front and two screws into the back of the flange.

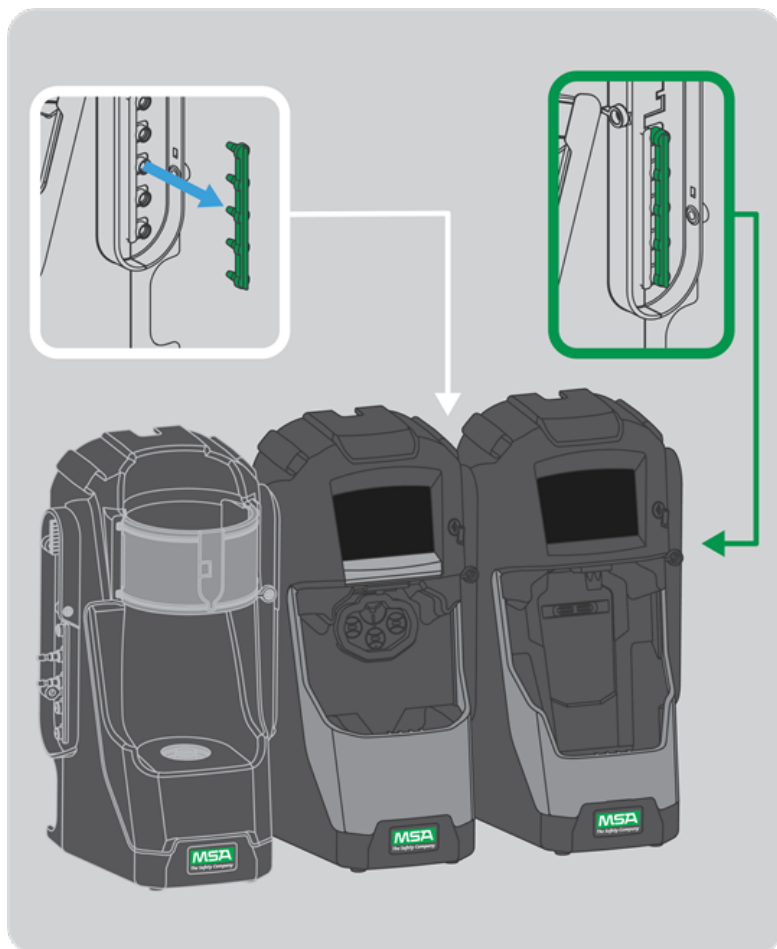

5. If connecting more than one Test Stand, remove the 5-port plug from the right side your last banked test stand.
6. Add the next Test Stand by removing the screws, and then firmly pushing the unit together on the right side of the bank.
7. Repeat Step 3 through Step 5 for each additional test stand.

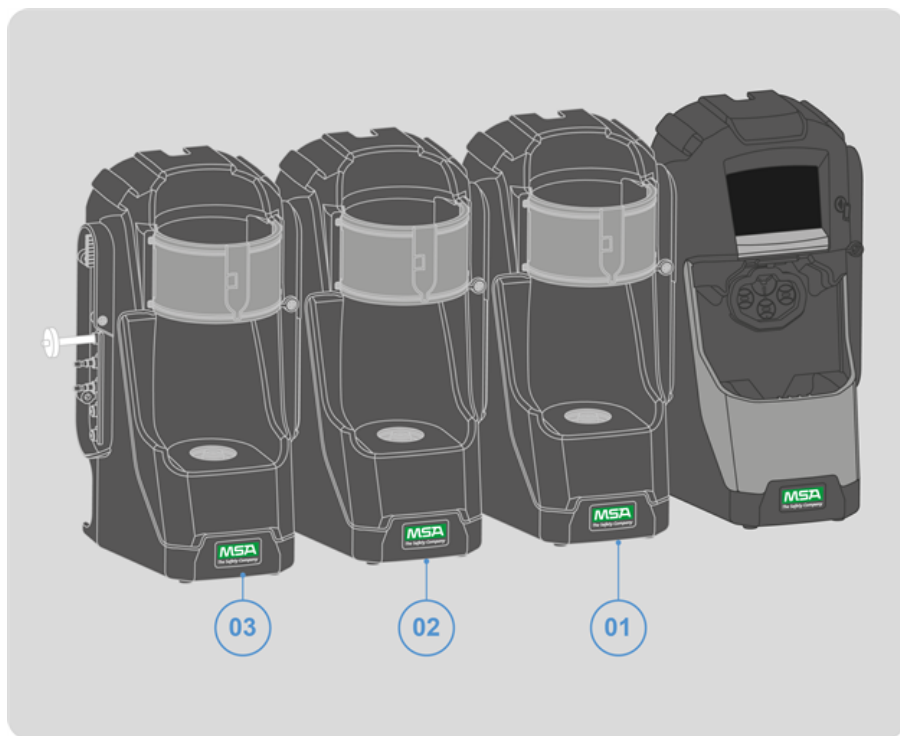

8. If connecting more than one Cylinder Holder, remove the supplied screws from the left side of the most recently installed Cylinder Holder. Set them aside for future use.
9. Add the next Cylinder Holder by aligning the barbed connectors and fittings and firmly pushing the unit together from the left side of the bank.



10. Screw the Cylinder Holders together using the supplied screws.



11. Remove the top barbed connector from the left most cylinder holder.



12. Install the Fresh Air Filter into the top port of the left most Cylinder Holder.

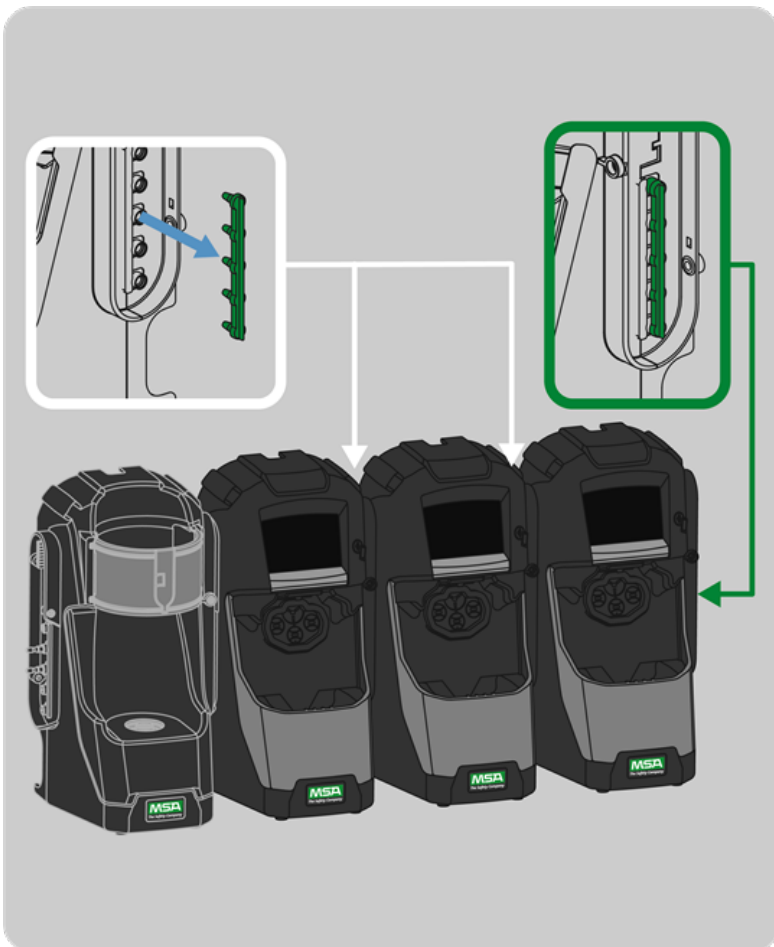

13. Ensure the green five-port plug is inserted on the right side of the rightmost test stand.

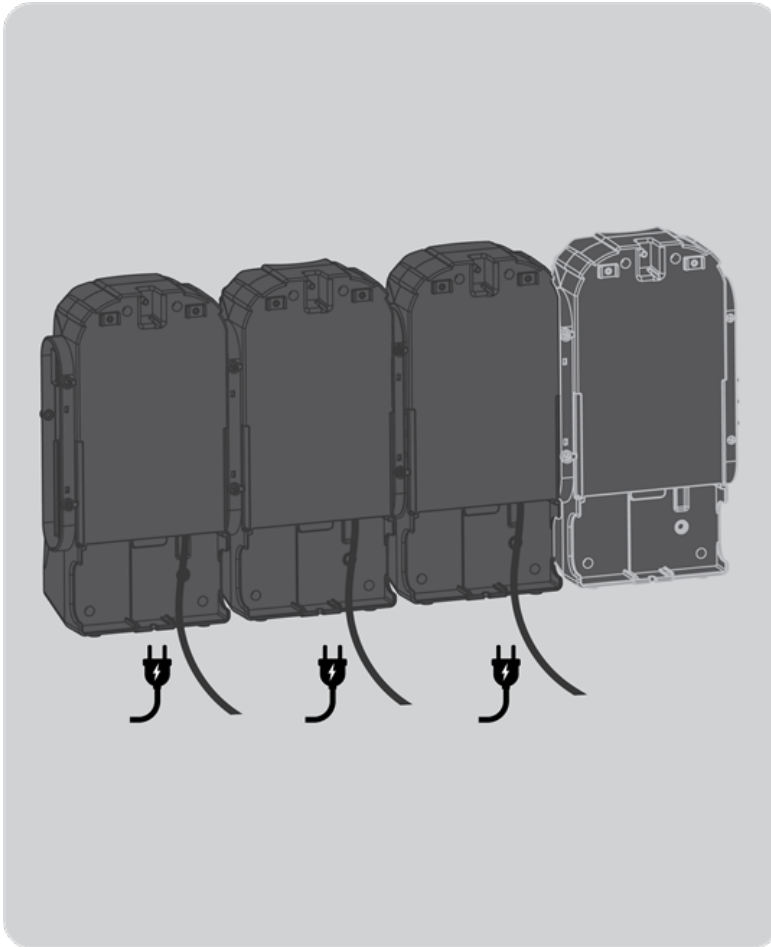

14. Insert the power jack into the power source for each Test Stand. Position the power supply away from the cylinder holder.
15. The Test Stand display should go through its power-on sequence, and the Cylinder Holder light band and the Test Stand light shield should illuminate. If this does not occur, firmly push the units together to ensure connectors are fully sealed.
16. Place the Dock on a flat, stable surface or wall mount it using the directions in this user guide.

When connecting two or more Test Stands, ensure the green five-port plug is secured on the right side of the farthest right unit to prevent gas leakage. Failure to do so may result in system malfunction.

The Cylinder Holder light band should illuminate once the power supply is connected to power. If illumination does not occur, firmly push the units together to ensure the connectors are fully seated.



When installing the Dock, please consider the environmental needs of your facility. If the customer desires, the Dock can be used in a ventilated area to assist in disbursing the test gas exhaust.

Failure to install some or all of the necessary screws can cause gas leakage, failed calibration, communication errors, light shield errors, and display errors.

3.4.1 Wall Mounting

When wall mounting the Bank, MSA recommends performing Steps 1-6 from [Installation](#) prior to installing on the DIN Rail. For a large configuration of Test Stands and Cylinder Holders, MSA recommends multiple people be used for installing or uninstalling from the DIN rail.

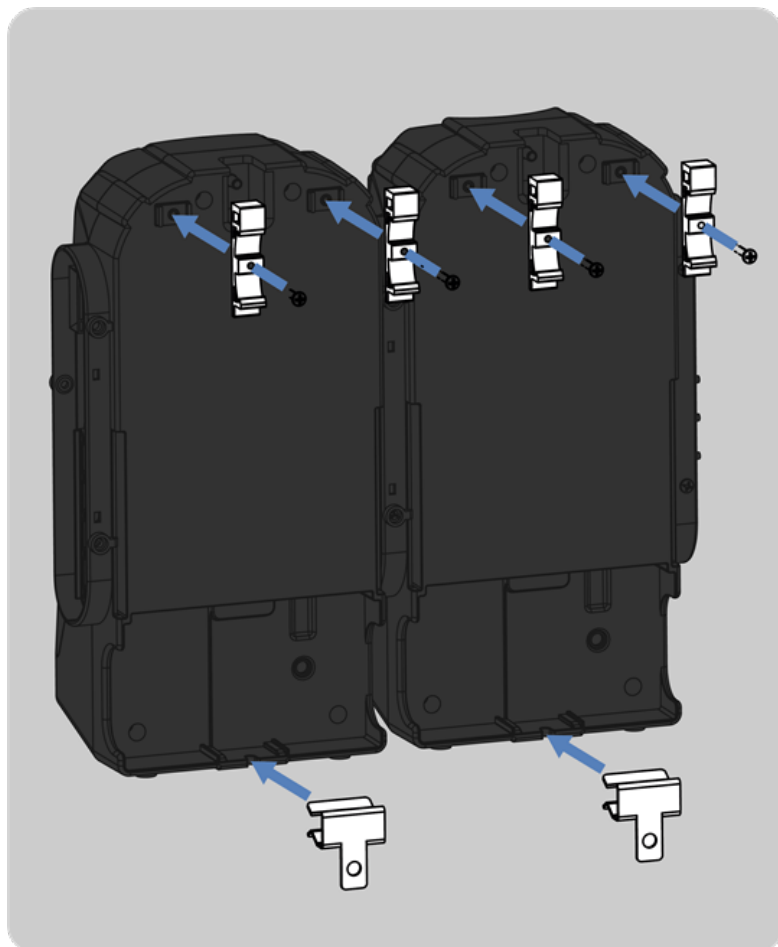

1. Secure the optional DIN rail Clips purchased separately to the rear of the Bank, using the included screws.

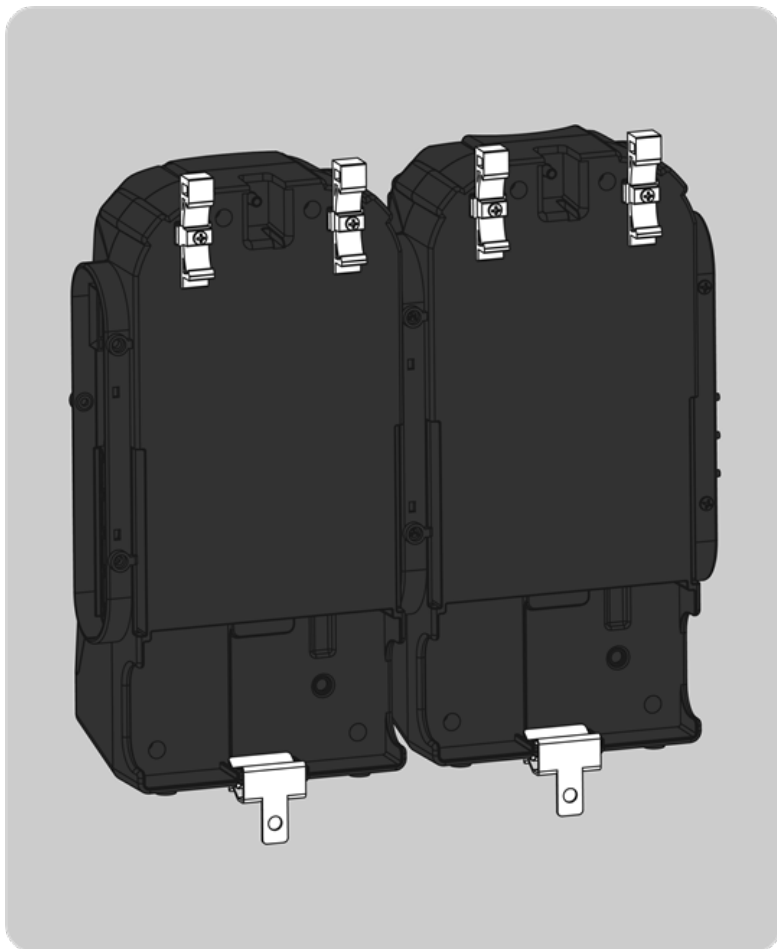

2. Mount the DIN rail (Type Omega) to the wall by securing it with wall anchors or other suitable fasteners.

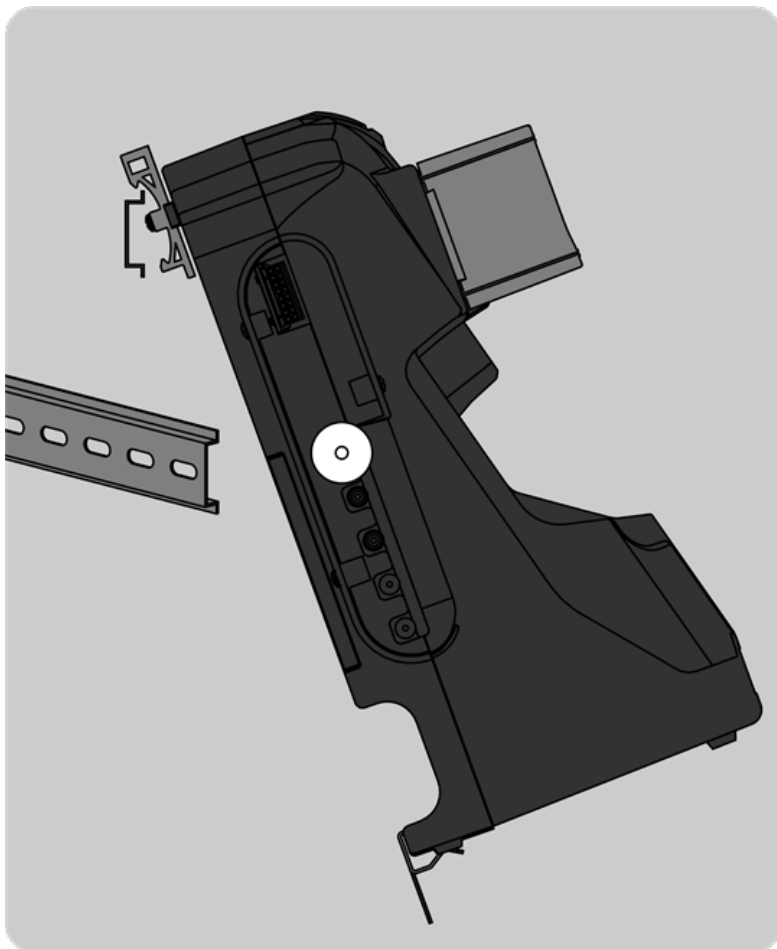

3. Align the bottom of the DIN rail clips on the lower edge of the wall-mounted DIN rail and snap the upper part of the clip into place.

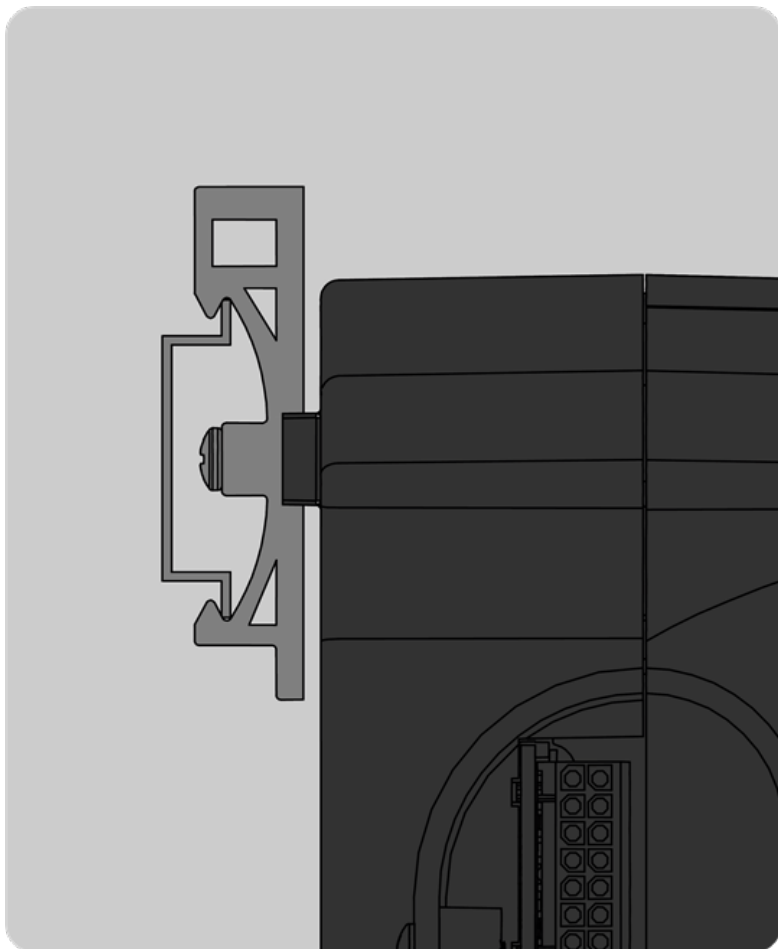

4. Ensure the upper part of the clip is in place on the DIN rail.

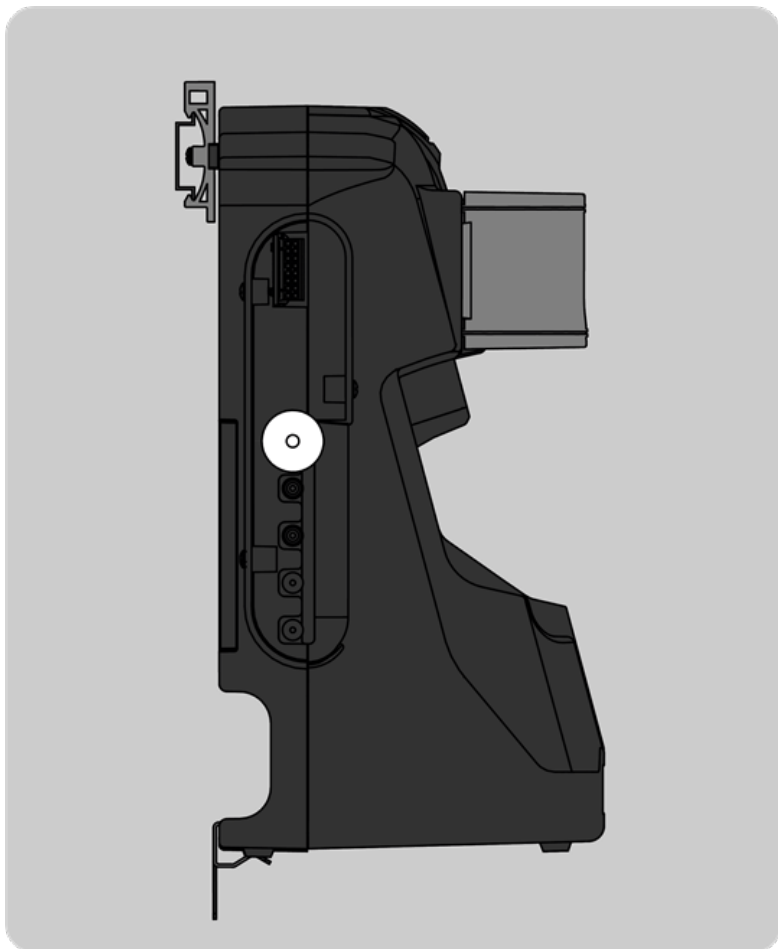

5. To remove from the DIN rail, pull the top of the clip forward to release from the top rail and push down on the unit to remove from the lower edge of the rail.

3.5 Commissioning

To commission a Bank to your Grid account, utilize the Grid mobile app. Commissioning your Bank is critical to make sure all Bank data is transmitted to your Grid account.

3.6 Basic Operation

3.6.1 Powering On / Off

Power On: To power on the Bank, simply plug it into a reliable power supply. The Dock does not have an on/off switch, as it is designed to always remain on.

Power Off: To power off the Bank, simply unplug it from the power source.

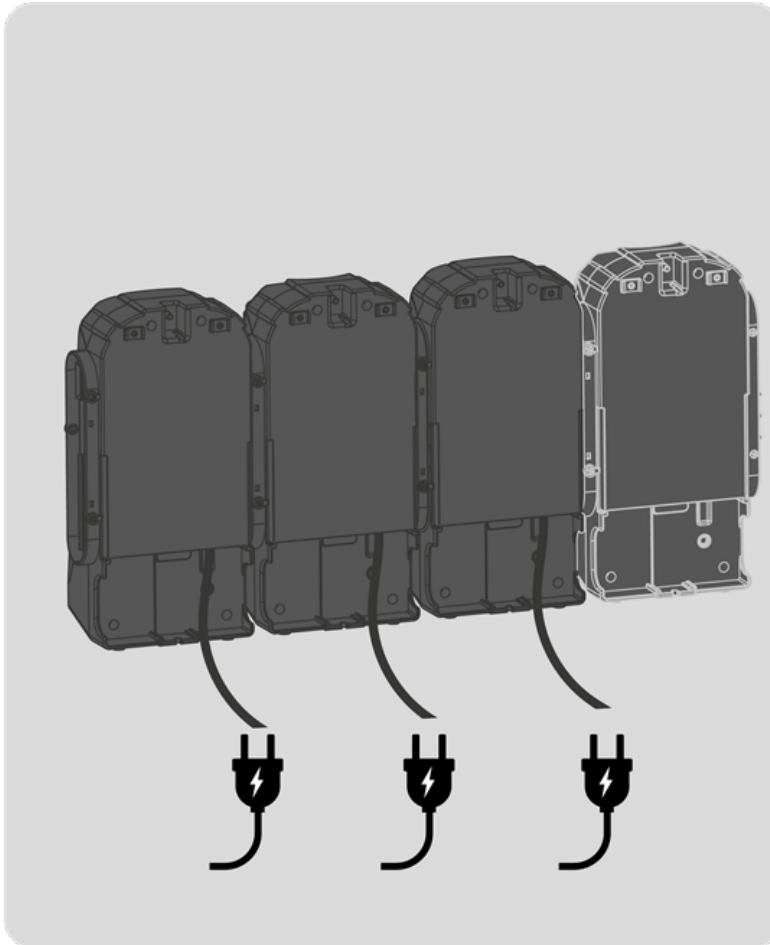

NOTE: To quickly power cycle the Bank by turning it off and on again, use a paperclip to press the white Reset button at the rear of the top of the Test Stand.

3.6.2 Installing Gas Cylinders

Installing and changing gas cylinders in the Cylinder Holders is a simple procedure.

⚠ WARNING!

- Ensure a clear path above the gas cylinder when installing or removing it. Do not place head, hands or other body parts above the gas cylinder when installing or removing it.
- Do not allow the gas cylinder to thread out of the gas cylinder valve when removing it from the Cylinder Holder. If the gas cylinder threads out of the gas cylinder valve, it can become a projectile.
- Do not overtighten the cylinder when installing. This can contribute to the gas cylinder unthreading from the gas cylinder valve when removing it.

Failure to follow these warnings can result in serious personal injury or death.

To change a gas cylinder:

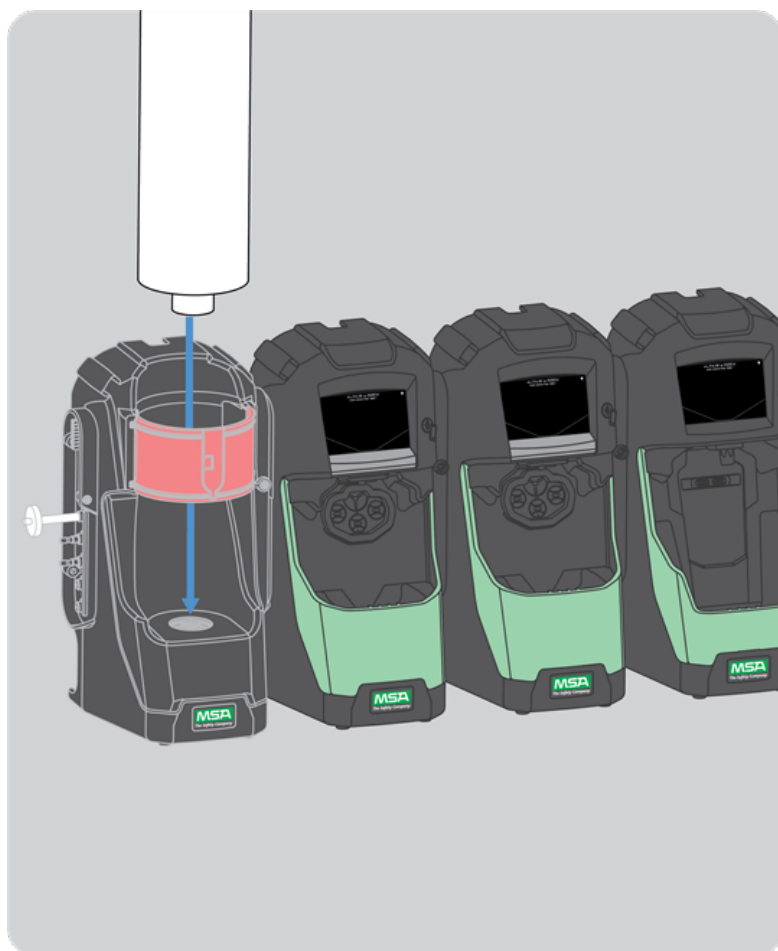

1. If a gas cylinder is already installed, unscrew it and remove it.
2. Insert the new gas cylinder into the Cylinder Holder.

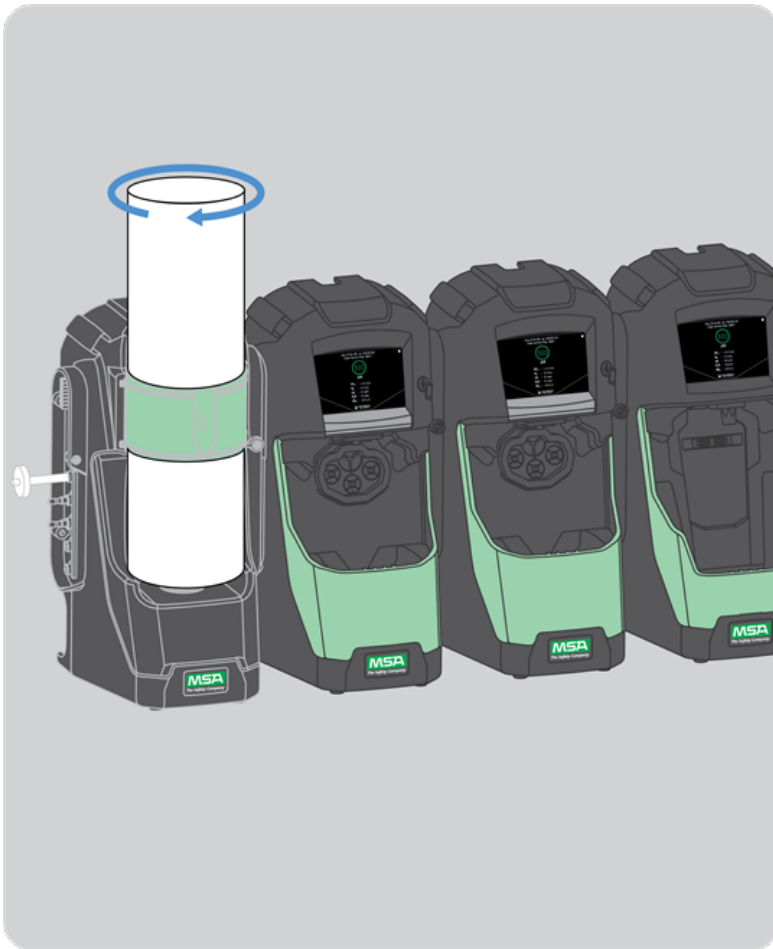

3. Screw a new test gas cylinder into the Cylinder Holder.
 - a. If you are using an RFID-tagged gas cylinder, the new cylinder data will be automatically populated in the system. The Cylinder holder light band will illuminate the appropriate color.
 - b. If you are not using an RFID-tagged gas cylinder, input the cylinder data using the Grid mobile app.

3.6.3 Special Conditions for Use with Reactive Gases

If using a Test Stand and Cylinder Holder for calibrating or bump testing a gas detector configured with a chlorine or ammonia sensor:

- Place the chlorine or ammonia gas cylinder in the Cylinder Holder closest to the Test Stand

Only one reactive gas Test Stand is allowed in a bank.

If connecting other Test Stands to the right of the reactive stand, plug the reactive gas outlet port with a white gas plug (included in spare parts kit) before mating the next Test Stand. Otherwise, inaccurate calibration could result on the reactive sensor.

Before the first use with reactive toxic gas, condition the regulator and Test Stand with the gas, by running the calibration twice in sequence. If using chlorine, perform this procedure daily before use.

If not using io Dock Cylinder Holders:

- Use a dedicated pressure regulator on the reactive toxic gas cylinder (for chlorine or ammonia, use P/N 10034391).
- Label the pressure regulator "FOR CHLORINE USE ONLY" or "FOR AMMONIA USE ONLY", as applicable (label stickers are provided with regulator).
- Use the shortest possible tubing running from the reactive toxic gas pressure regulator to the Test Stand's "CYLINDER 1" port. Before the first use with reactive toxic gas, condition the regulator and Test Stand with the gas by running the calibration twice sequentially; for chlorine, perform this procedure daily before use.

Many gases have a cross-sensitivity to other gases. Ensure that test cylinder gases do not contain other interfering gases.

The io Dock does not support the calibration or bump testing of chlorine dioxide (ClO₂) sensors due to the reactive nature of the gas.

3.6.4 Home Screen

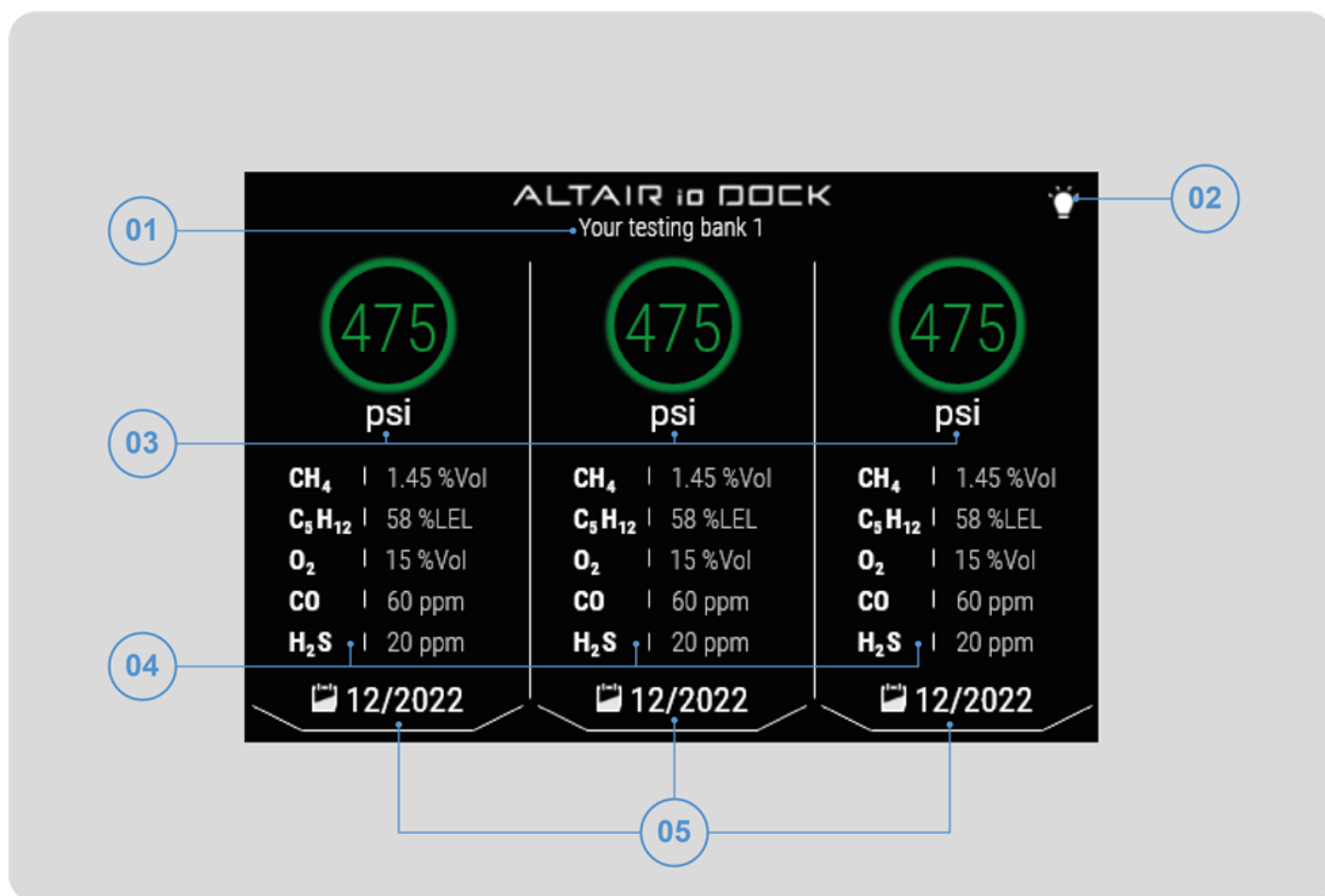

| | | | |
|----|-----------------------------|----|--------------------------|
| 01 | Bank Name | 04 | Gas Cylinder Data |
| 02 | Test Mode | 05 | Cylinder Expiration Date |
| 03 | Gas Cylinder Pressure Gauge | | |

3.6.5 Inserting the Instrument

ALTAIR io 4

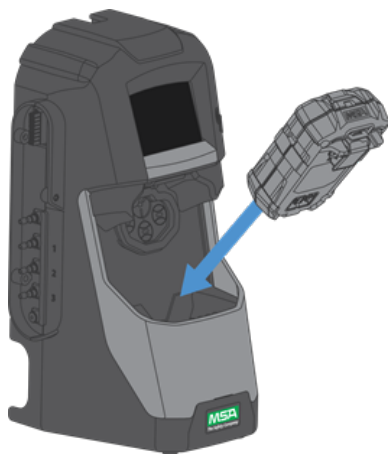

1. Point the front of the device at the dock stand.

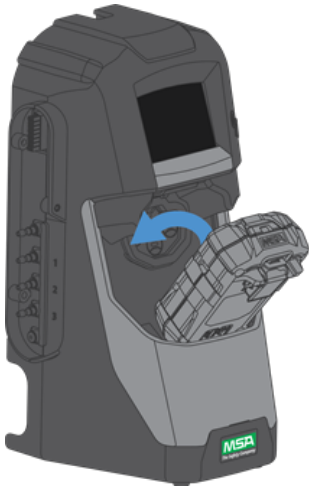

2. Place the bottom of the device into the cradle behind the test stand light shield.

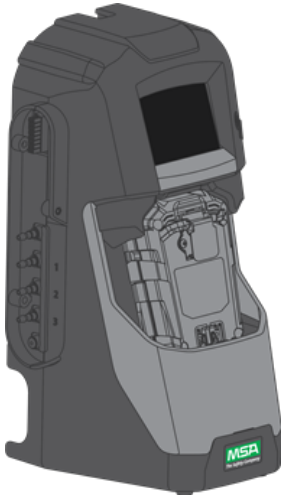

3. Push the top of the device into the dock test stand until you hear a click.

ALTAIR io 6

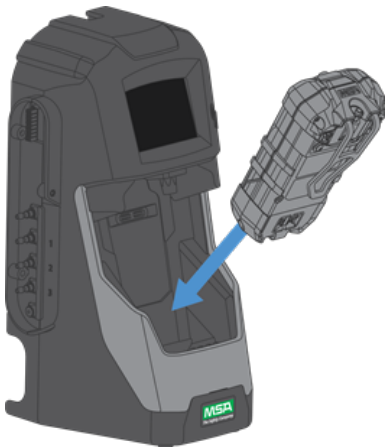

1. Point the front of the device at the dock test stand.

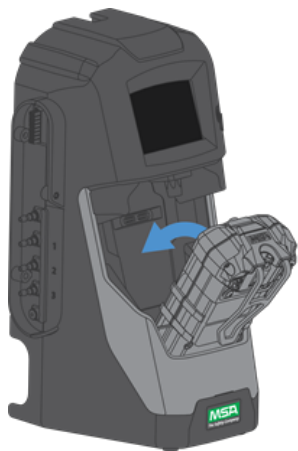

2. Place the bottom of the device into the gray cradle behind the test stand light shield and press down.

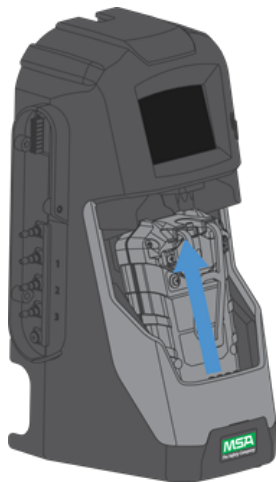

3. Rotate the device into place, guiding the bard into the adapter of the test stand, and release.

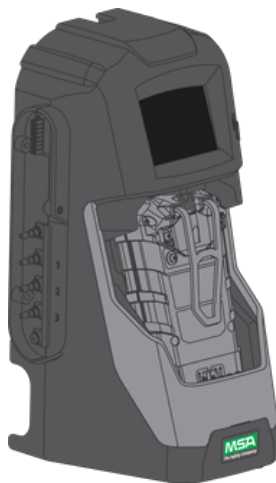

3.6.6 Removal of the Instrument

ALTAIR io 4

1. Press the gray Eject Button above the device.
2. Remove the device from the dock test stand.

ALTAIR io 6

1. Grab the device and press downward
2. Rotate the device out of the dock test stand.

3.6.7 Running a Test

The Dock performs two types of tests:

- A **Bump Test** (or Functional Check) is a qualitative check conducted by applying a known challenge gas to the device. The purpose of this check is to confirm sensor functionality and to verify the integrity of the flow path to the sensor(s).
- A **Calibration** adjusts the sensor output to match the precise concentration value of a known traceable calibration cylinder. Calibration can be performed at any time to ensure sensor accuracy.

NOTE: There may be a slight delay between the insertion of the device and start of gas testing while communication between the device and test stand occur.

- If the device has not fully completed its warm-up, it will do so prior to beginning a test.

Bump Test

To perform the automatic bump test:

1. Insert the device with the display facing the Dock Test Stand.
2. The appropriate test runs automatically and indicates bump test results upon completion.
3. Remove the ALTAIR io device.

Calibration

WARNING!

Do not perform a calibration unless you are certain you are in fresh, uncontaminated air; otherwise, inaccurate readings can occur which can falsely indicate that a hazardous atmosphere is safe.

Failure to follow this warning can result in serious personal injury or death.

To perform the automatic calibration:

1. Insert the device into the Dock Test Stand.
2. The appropriate test runs automatically and indicates the calibration results upon completion.
3. Remove the ALTAIR io device.

Live LEL readings displayed during calibration are indicative of calibrated values and are not necessarily indicative of the true LEL of calibration gas being applied. For example, if using 2.5% volume methane to calibrate to a general combustible reading, live readings during calibration will indicate a 100% LEL reading, even though calibration gas being used is only 57% LEL.

4 Features

4.1 Connection to Grid

The ALTAIR io DOCK leverages the connectivity of the ALTAIR io device for communications back to Grid. Updated Bank status and test results are reported back to ALTAIR io device following each test.

4.2 Test Modes

The ALTAIR io DOCK allows for many test modes to suit your operations. These test modes are independently configurable for each test stand in a bank.

4.2.1 Smart Mode

Dock will perform a bump test or calibration as required by the Grid-configured gas detector settings without user intervention. This mode allows for hands-off, intuitive operation of the Dock to help ensure device compliance. The device will perform a bump test or calibration when the Grid-configured bump test or calibration interval has elapsed.

4.2.2 Bump Test Only Mode

Dock will always perform a bump test on the inserted device, regardless of whether it needs a bump test or not. In this mode, a calibration will never be performed.

4.2.3 Calibration Only Mode

Dock will always perform a calibration on the inserted device, regardless of whether it needs a calibration or not. In this mode, a bump test will never be performed.

4.2.4 Bump Test / Calibration on Bump Test Fail Mode

Dock will first perform a bump test. If the bump test fails, it will then proceed to perform a calibration. Note that if a calibration is due on the device, it will skip the bump test and proceed directly to calibration.

4.3 Configuration

Configuration of banks is done through the Grid mobile app.

4.4 Bank Status

4.4.1 Test Stand Status

The Dock communicates its status through the display user interface and the front light shield. In conjunction, the display and light stand communicate the following statuses:

| Light Shield | Status | Display |
|----------------|------------------|---|
| Solid Green | Idle & Ready | Shows calibration gas cylinders installed. |
| Breathing Blue | Test in Progress | Shows test details. |
| Flashing Green | Test Pass | Shows green sensor rings. |
| Flashing Red | Test Fail | Shows one or more red sensor rings. |
| Solid Red | Test Stand Error | Shows error message on banner and gas data related to error is highlighted. |

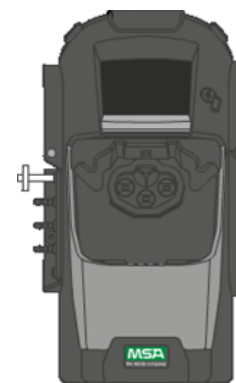

4.4.2 Cylinder Holder Status

Gas cylinder status is communicated using the Cylinder Holder's light band.

4 Features

| Light Shield | Cylinder Status: RFID-Tagged Cylinders | Cylinder Status: Non-RFID Cylinders |
|--------------|---|--|
| Solid Green | Full [approximately 99 psi (6.89 bar)] and Within Expiration Limits | Full [approximately 99 psi (6.89 bar)] |
| Solid Yellow | Low [approximately 49 psi (3.45 bar)] or Expiring Soon (≤ 4 weeks) | Low [approximately 49 psi (3.45 bar)] |
| Solid Red | Empty [< 10 psi (0.69 bar)] or Expired | Empty [< 10 psi (0.69 bar)] |
| Flashing Red | Holder Malfunction | Holder Malfunction |

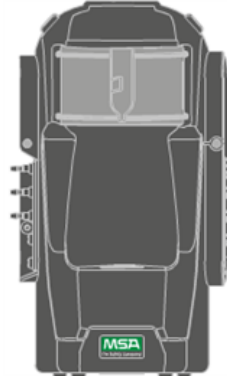

4.5 Automatic Gas Cylinder Recognition

When using MSA calibration gas equipped with an RFID tag, the Cylinder Holder will automatically detect the cylinder gas data, including:

- Gas Type(s)
- Gas Concentration(s)
- Expiration Date
- Lot Number
- Cylinder Part Number

NOTE: The RFID tag is only available on MSA-branded test gas cylinders.

4.6 Gas Cylinder Manual Configuration

Gas cylinder configuration can be performed through the Grid mobile app.

5 Device Care

5.1 Maintenance

WARNING!

Repair or alteration of the ALTAIR io DOCK beyond the scope of these instructions by anyone other than personnel authorized by MSA can endanger persons who rely on this equipment for their safety or health and may void all warranties and approvals. Use only genuine MSA replacement parts.

Failure to follow this warning can result in serious personal injury or death.

5.1.1 Cleaning

Routine Cleaning

Clean the exterior of the DOCK regularly using only a damp cloth, lint-free cloth, or microfiber cloth. Do not use cleaning agents, as many contain silicone or alcohol, which will damage the sensors of the ALTAIR io device.

Dust and Dirt Exposure

Use a dry, soft bristled brush to remove any dust or dirt that has accumulated on the apparatus.

5.1.2 Fresh Air Filter Replacement

The disposable fresh air filter is located on the tubing attached to the upper port on the left side of the farthest left unit. The filter requires periodic replacement, based on the unit's frequency of use and environmental cleanliness. Visual inspection of the fresh air filter will indicate contamination.

To replace the Fresh Air Filter:

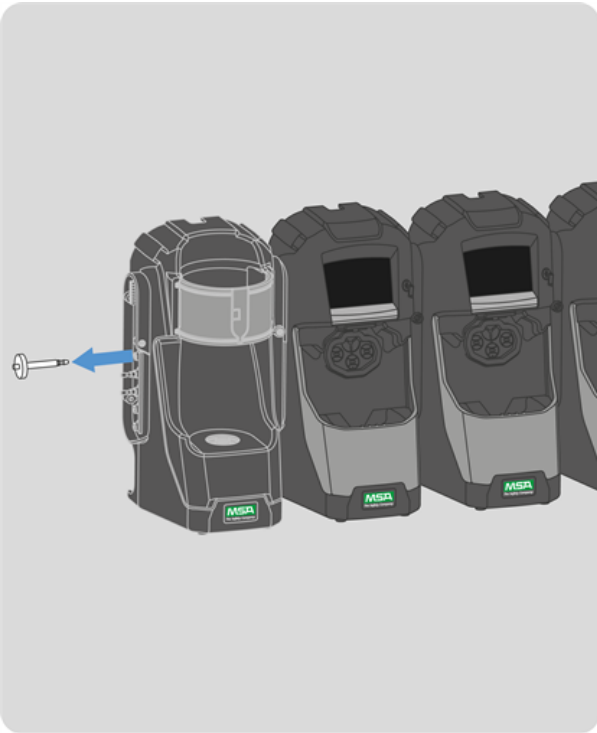

1. Remove the filter and tubing from the barb fitting in the fresh air port on the left side of the farthest left unit.
2. Dispose of the old filter.



3. Insert the new filter and tube onto the same barb fitting of the fresh air port.



Pump alerts may indicate the need to replace the fresh air filter.

Do not run the unit without the filter in place; otherwise the valves and pumps may be damaged.

5.1.3 O-Ring Seal Replacement for Cylinder Holder

Periodically, visually inspect the O-ring on the regulator fitting, clean if necessary and replace if any damage is found.

To replace the O-ring seal:

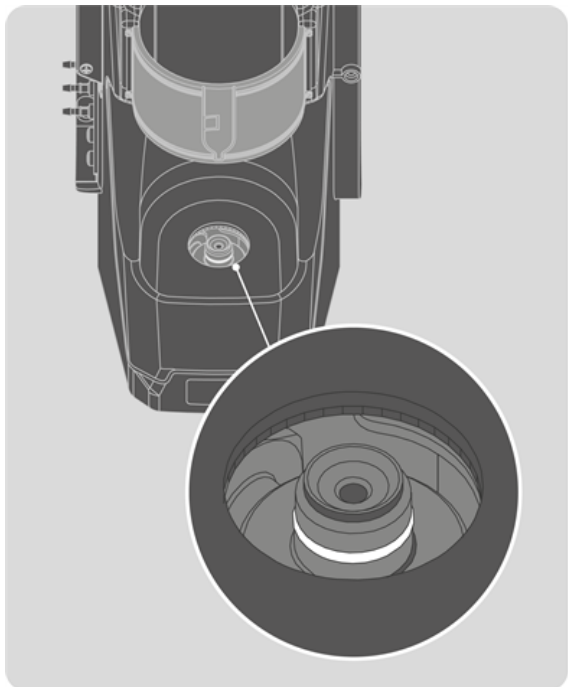

1. Remove the damaged O-ring.
2. Clean the fitting with a water-dampened cloth and apply a light film of mineral oil to the new O-ring.

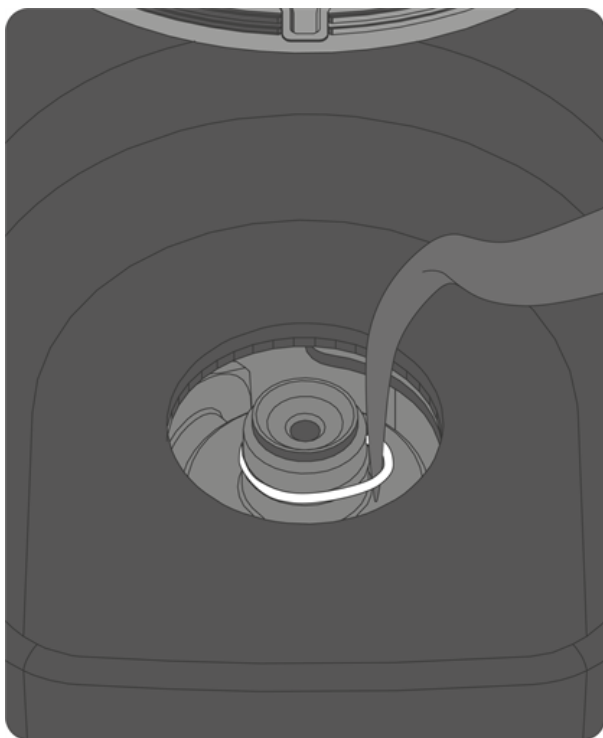

3. Place the new O-ring onto the fitting.

⚠ WARNING!

Do not use a silicone-based lubricant on the O-ring. Silicone can desensitize the combustible gas sensor, thereby giving erroneously low readings.

Failure to follow this warning can result in serious personal injury or death.

5.1.4 Replacing the Light Band - Cylinder Holder

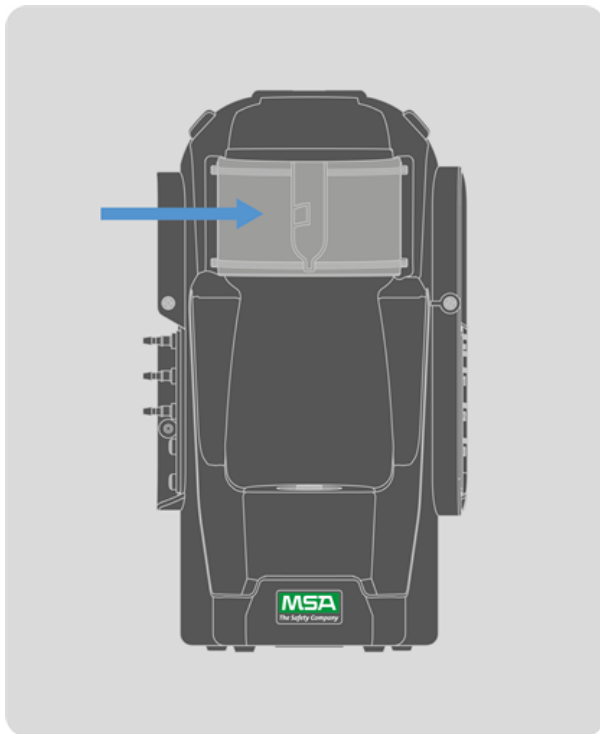

1. Remove the light band from the front of the cylinder holder.
2. Insert the new light band.

5.2 Troubleshooting

Before performing troubleshooting steps, check the Grid mobile app to ensure the Dock is using the latest software revision. Once you have verified that the software is up to date, you can diagnose the following abnormal conditions:

- [Device Will Not Initiate a Bump or Calibration](#)
- [Device Fails Zero Calibration or Bump](#)
- [Device Fails Span Calibration or Bump](#)
- [Cylinder Data Does Not Display or Displays Incorrectly](#)
- [Test Stand Errors](#)
- [Pump or Flow Fault](#)
- [Automated Testing Does Not Occur](#)

5.2.1 Device Will Not Initiate a Bump or Calibration

1. Ensure the device is charged, turned on, and errors are not displayed.
2. Ensure the gas cylinder is not empty or expired.
 - a. If the gas cylinder is empty and you are using an RFID-tagged gas cylinder, the Cylinder Holder light shield will be solid red.
3. Ensure the device is seated securely in the Test Stand.
4. Check the bump or calibration dates to ensure a bump or calibration is necessary.
 - a. If the Dock is in Smart Mode and the device does not require a bump or calibration based on elapsed time, the device will not automatically initiate a bump or calibration.
5. Verify errors are not displayed from the Cylinder Holder.
6. Ensure the Dock Test Stand is set in the desired Test Mode.
7. Ensure the Test Stand display is showing the Home Screen.
8. Ensure the Bank is correctly assembled by checking the three screws between each connection.
9. Ensure that you are not connected via Bluetooth with the Grid mobile app, as show on the Dock Test Stand Display.

10. Implement a line conditioner or UPS if the supplied power is noisy.

5.2.2 Device Fails Zero Calibration or Bump

1. Ensure the device is seated securely in the Test Stand.
2. Check the Fresh Air filter and replace it if contaminated.
3. Ensure that the atmosphere is free of any interfering gas.
4. Ensure the ALTAIR io 4 Test Stand gasket is free of dirt and debris and is in good condition. For the ALTAIR io 6: Ensure the Test Stand adapter is free of dirt and debris.
5. Ensure the ALTAIR io device front case filters are in good condition.

5.2.3 Device Fails Span Calibration or Bump

1. Check the right side of the farthest right unit to ensure the green five port plug is secure over the gas outlet connections.
2. Check the sides of each unit to ensure the gas line barb fittings are in place and aligned between the Test Stands and Cylinder Holders. Misaligned barbs can lead to gas leakage.
3. Ensure the cylinder configuration is correct and calibration gas concentrations/units match the setpoints in the instrument.
4. If the gas cylinder is not RFID-tagged, ensure the calibration gas is not expired.
5. For manual calibrations, ensure the correct regulator is being used.
6. Ensure the Test Stand instrument gasket is free of dirt and debris and is in good condition.
7. Ensure the ALTAIR io 4 front case filters are in good condition. For the ALTAIR io 6: Ensure the Test Stand adapter is free of dirt and debris.
8. If repeated failures occur, replace sensor per device user guide instructions.

Occasionally, in normal use conditions, electrochemical sensors can be exposed to either very high levels of the target gas or to an interferent gas, which can saturate the sensor electrolyte or filter. If this type of saturation occurs, it may affect the sensors performance and ability to zero or span calibrate.



This is typically a temporary effect and the sensor will self-recover if left in fresh air. The recovery time is dependent on the saturation gas and the level of exposure, but is less than 24 hours in almost all cases. Recovery should be attempted prior to sensor replacement.

5.2.4 Cylinder Data Does Not Display or Displays Incorrectly

If using a Cylinder Holder with RFID-tagged MSA gas cylinders, the general cylinder parameters automatically populate. If using test gas from an independent source the user must manually enter the cylinder data in the Grid mobile app.

The home screen only displays Part Number, Lot Number, and Expiration fields if using MSA RFID-tagged calibration gas.

If cylinder data does not display:

1. The Cylinder Holder and Test Stand may not be communicating via the connector. Remove the flange screws and push the two stands together. If a valid pressure reading displays, reinsert the flange screws.
2. Ensure the test gas cylinder is properly screwed into the base.
3. If not using an RFID-tagged gas cylinder, verify that cylinder parameters have been entered.
4. Ensure the appropriate Bank and Cylinder Holder has been configured.
 - a. Duplicate Bank names can cause the user to inadvertently configure the wrong Bank or Cylinder Holder.

5.2.5 Test Stand Errors

Test stand error details can be found by utilizing the Grid mobile app.

6 Learn More

5.2.6 Pump or Flow Fault

A Pump or Flow Fault occurs if pump(s) is blocked during a test, the test cylinder(s) read empty, the fresh air filter is clogged, or an internal flow error occurs.

If a Pump or Flow Fault occurs:

1. Visually inspect the air filter for contamination and replace as needed.
2. Refer to [Device Will Not Initiate a Bump or Calibration](#).
3. For an ALTAIR io6 Dock, this error could also occur if the adapter was clogged/dirty.

5.2.7 Automated Testing Does Not Occur

Verify that all conditions for Smart Mode testing are met. If yes, verify that:

1. Adequate gas cylinder pressure is available.
2. The instrument was securely in the Test Stand, turned on, and no errors were displayed.
3. There were no Test Stand errors.
4. The Test Stand display is showing the Home Screen.

If these conditions are true:

1. Turn the gas detector on and insert it into the Test Stand in Bump or Calibration mode, and verify that a test occurs.
2. If a test does not occur, use the status information or error messages on the screen to diagnose the problem.

NOTE: In Smart Mode, the device will only perform a bump test or calibration when the applicable Grid-configured interval has elapsed.

6 Learn More

6.1 Disposal and Recycling

Dispose of the DOCK in accordance with local health and safety regulations.

6.2 Replacement Parts

Replacement part numbers and information can be found on the ALTAIR io DOCK product page.

6.3 Warranty

The warranties made by MSA with respect to the product are voided if the product is not used and serviced in accordance with the instructions in this manual. Protect yourself and others by following them. We encourage our customers to contact MSA regarding this equipment prior to use or for any additional information relative to use or repairs.

| ITEM | WARRANTY PERIOD |
|--|--|
| ALTAIR io DOCK Test Stand, Cylinder Holder, and Multi Unit Charger | <p>MSA warrants that this product will be free from mechanical defects and faulty workmanship for a period of two (2) years from date the product is first used, provided it is maintained and used in accordance with MSA's instructions and/or recommendations. Warranty shall not exceed two years and six months from the date of manufacture.</p> <p>An exception to the above is when the product is leased under an MSA+ subscription. In that case, MSA warrants that this product will be free from mechanical defects and faulty workmanship for the term of the subscription agreement.</p> |

This warranty does not cover filters, fuses, etc. Certain other accessories not specifically listed here may have different warranty periods. This warranty is valid only if the product is maintained and used in accordance with Seller's instructions and/or recommendations.

The Seller shall be released from all obligations under this warranty in the event repairs or modifications are made by persons other than its own or authorized service personnel or if the warranty claim results from physical abuse or misuse of

the product. No agent, employee or representative of the Seller has any authority to bind the Seller to any affirmation, representation or warranty concerning this product.

Seller makes no warranty concerning components or accessories not manufactured by the Seller, but will pass on to the Purchaser all warranties of manufacturers of such components.

THIS WARRANTY IS EXCLUSIVE AND IN LIEU OF ALL OTHER WARRANTIES, EXPRESSED, IMPLIED OR STATUTORY, AND IS STRICTLY LIMITED TO THE TERMS HEREOF. SELLER SPECIFICALLY DISCLAIMS ANY WARRANTY OF MERCHANTABILITY OR OF FITNESS FOR A PARTICULAR PURPOSE, TITLE, AND NON-INFRINGEMENT, AND ALL WARRANTIES ARISING FROM COURSE OF DEALING, USAGE, OR TRADE PRACTICE. SELLER MAKES NO WARRANTY OF ANY KIND THAT THE PRODUCT OR ANY SOFTWARE THEREIN OR USED IN CONNECTION WITH THE PRODUCT WILL MEET PURCHASER'S OR ANY OTHER PERSON'S REQUIREMENTS, OPERATE WITHOUT INTERRUPTION, ACHIEVE ANY INTENDED RESULT, BE COMPATIBLE OR WORK WITH ANY SOFTWARE, SYSTEM OR OTHER SERVICES, OR BE SECURE, ACCURATE, COMPLETE, FREE OF HARMFUL CODE, OR ERROR FREE.

DISCLAIMER: WHILE THE DEVICE WILL STILL OPERATE LOCALLY AS A GAS DETECTOR, WITHOUT AN ACTIVE SUBSCRIPTION, DEVICES WILL HAVE LIMITED FUNCTIONALITY, INCLUDING, BUT NOT LIMITED TO THE INABILITY TO CONFIGURE THE DEVICE. IF NOT CONNECTED TO THE GRID, MSA RECOMMENDS TAKING THE DEVICE OUT OF USE. ADDITIONALLY, SOME LOCAL DEVICE FUNCTIONALITY MAY BE IMPAIRED, INCLUDING, BUT NOT LIMITED TO, THE ABILITY TO UNLOCK THE DEVICE IF MSA ID ASSIGNMENT LOCK IS ENABLED OR REPEATED CELLULAR CONNECTION LOST NOTIFICATIONS.

Exclusive Remedy

It is expressly agreed that Purchaser's sole and exclusive remedy for breach of the above warranty, for any tortious conduct of Seller, or for any other cause of action, shall be the repair or replacement at Seller's option, of any equipment or parts thereof, which after examination by Seller is proven to be other than as warranted. Replacement equipment and/or parts per the previous sentence will be provided at no cost to Purchaser, F.O.B. Seller's Plant. Failure of Seller to successfully replace any nonconforming equipment or parts shall not cause the remedy established hereby to fail of its essential purpose or later any limitation of liability found herein.

Exclusion of Consequential Damage

PURCHASER SPECIFICALLY UNDERSTANDS AND AGREES THAT UNDER NO CIRCUMSTANCES WILL SELLER BE LIABLE TO PURCHASER FOR ECONOMIC, SPECIAL, INCIDENTAL OR CONSEQUENTIAL DAMAGES OR LOSSES OF ANY KIND WHATSOEVER, INCLUDING BUT NOT LIMITED TO, LOSS OF ANTICIPATED PROFITS AND ANY OTHER LOSS CAUSED BY REASON OF NONOPERATION OF THE GOODS. THIS EXCLUSION IS APPLICABLE TO CLAIMS FOR BREACH OF WARRANTY, TORTIOUS CONDUCT OR ANY OTHER CAUSE OF ACTION AGAINST SELLER.

6.4 China RoHS Requirement

| Part Name | Hazardous Substances | | | | | |
|----------------|----------------------|--------------|--------------|-------------------------------|--------------------------------|---------------------------------------|
| | Lead (Pb) | Mercury (Hg) | Cadmium (Cd) | Hexavalent Chromium (Cr (VI)) | Polybrominated biphenyls (PBB) | Polybrominated diphenyl ethers (PBDE) |
| ALTAIR io DOCK | ○ | ○ | ○ | ○ | ○ | ○ |

O: Indicates that said hazardous substance contained in all of the homogeneous materials for this part is below the limit requirement of GB/T 26572.

X: Indicates that said hazardous substance contained in at least one of the homogeneous materials used for this part is above the limit requirement of GB/T 26572.