



**Operating Manual**  
**PrimaX**  
**Gas Transmitter / Software Version V1.19**



Order No.: 10115083/06

For countries of Russian Federation, Republic of Kazakhstan and Republic of Belarus, the gas detector will be delivered with a passport document that includes valid approval information. On the CD with manual instruction attached to the gas detector the user will find the documents "Type Description" and "Test Method" - appendixes to Pattern Approval Certificate of Measuring instrument, valid in the countries of use.

The Declaration of Conformity can be found under the following link: <https://MSAsafety.com/DoC>.

MSA is a registered trademark of MSA Technology, LLC in the US, Europe and other Countries. For all other trademarks visit <https://us.msasafety.com/Trademarks>.



***The Safety Company***

MSA Europe GmbH  
Schlüsselstrasse 12  
8645 Rapperswil-Jona  
Switzerland

For your local MSA contacts, please go to our website [www.MSAsafety.com](http://www.MSAsafety.com)

---

# Contents

<b>1</b>	<b>Safety Regulations</b> .....	<b>5</b>
1.1	Correct Use .....	5
1.2	Liability Information .....	5
1.3	Safety and Precautionary Measures to be Adopted .....	5
1.4	MSA Permanent Instrument Warranty .....	6
<b>2</b>	<b>Description</b> .....	<b>8</b>
2.1	Identifying the Unit .....	8
2.2	Overview .....	8
<b>3</b>	<b>Installation</b> .....	<b>10</b>
3.1	Mechanical Installation .....	10
3.2	Electrical Installation .....	11
3.2.1	Electrical Connection - PrimaX P .....	12
3.2.2	Electrical Connection - PrimaX I .....	13
<b>4</b>	<b>Operation</b> .....	<b>15</b>
4.1	Startup .....	15
4.2	Menu Sequence .....	16
4.3	Calibration .....	17
4.4	Maintenance and Info .....	19
4.5	Password .....	21
4.6	Changeable Parameters .....	22
4.7	Optional HART Module and Relay .....	22
4.7.1	HART .....	22
4.7.2	Electrical installation .....	23
4.7.3	Relays .....	23
4.8	Relay Operation .....	24
4.8.1	Startup .....	24
4.8.2	Menu Sequence .....	24
<b>5</b>	<b>Maintenance</b> .....	<b>27</b>
5.1	Changing the Sensors .....	27
<b>6</b>	<b>Technical Data</b> .....	<b>29</b>
6.1	Specifications .....	29
6.2	Cable Lengths and Cross-sections .....	30
6.3	Performance Specifications .....	30
6.4	List of Detectable Gases and Response Time .....	32
6.5	Sensor Response to Interferants .....	33
6.6	PrimaX P List of Combustible Gases and Vapours detectable with Catalytic Sensor P/N 10112716 .....	35
<b>7</b>	<b>Approvals</b> .....	<b>36</b>
7.1	Marking, Certificates and Approvals according to the Directive .....	36

	2014/34/EU (ATEX) and National Standards .....	
7.2	Marking and Certificates according to IECEx .....	39
7.3	Special conditions for the safe use according to ATEX, EN 50104, and SIL applications .....	40
7.4	Safety Relevant Parameters [40°C] .....	42
7.4.1	Application with 4-20 mA Current Output .....	42
<b>8</b>	<b>Accessories .....</b>	<b>44</b>
8.1	Calibration Cap .....	44
8.2	Sensor Gard .....	44
8.3	Remote Calibration .....	45
8.3.1	Installation .....	45
8.3.2	Operation .....	45
8.4	Flow Through Adapter .....	46
8.5	Duct Mounting Kit .....	47
8.6	Pipe Mounting Kit .....	47
8.7	Sensor Tag .....	48
8.8	Sunshield .....	49
8.9	Universal HART Cable .....	50
<b>9</b>	<b>Disposal .....</b>	<b>50</b>
<b>10</b>	<b>Spare Parts .....</b>	<b>51</b>
<b>11</b>	<b>Appendix .....</b>	<b>53</b>
11.1	Output States .....	53
11.2	Calibration Errors .....	54
11.3	Error Codes .....	54
11.4	Timeout .....	54
11.5	Mechanical Installation .....	55
11.6	Wiring Diagrams .....	57

# 1 Safety Regulations

## 1.1 Correct Use

The PrimaX Gas Transmitters are fixed gas transmitters for measuring toxic or combustible gases and for monitoring oxygen deficiency, excess or inerting. They are suitable for outdoor and indoor applications without limitations, e.g. offshore industry, chemical and petrochemical industry, water and sewage industry. The signal of the transmitter can be used in combination with MSA control units for further actions in safety or non safety applications, e.g. MSA SUPREMA, Gasgard XL, 9010/9020.

The two versions of the gas transmitter are delivered either in a flameproof or in a intrinsically safe enclosure. The electrical parts and interfaces have the same basic functionality.

It is imperative that this operating manual be read and observed when using the device. In particular, the safety instructions, as well as the information for the use and operation of the device, must be carefully read and observed. Furthermore, the national regulations applicable in the user's country must be taken into account for a safe use.



### WARNING!

This product is supporting life and health. Inappropriate use, maintenance or servicing may affect the function of the device and thereby seriously compromise the user's life.

Before use, the product operability must be verified. The product must not be used if the function test is unsuccessful, it is damaged, a competent servicing/ maintenance has not been made, genuine MSA spare parts have not been used.

**Failure to follow this warning can result in serious personal injury or death.**

Alternative use, or use outside this specification will be considered as non-compliance. This also applies especially to unauthorised alterations to the product and to commissioning work that has not been carried out by MSA or authorised persons.

## 1.2 Liability Information

MSA accepts no liability in cases where the product has been used inappropriately or not as intended. The selection and use of the product are the exclusive responsibility of the individual operator.

Product liability claims, warranties also as guarantees made by MSA with respect to the product are voided, if it is not used, serviced or maintained in accordance with the instructions in this manual.

## 1.3 Safety and Precautionary Measures to be Adopted



### WARNING!

The following safety instructions must be observed implicitly. Only in this way can the safety and health of the individual operators, and the correct functioning of the device, be guaranteed.

- The device described in this manual must be installed, operated and maintained in strict accordance with their labels, cautions, instructions, and within the limitations stated.
- Read the procedures described in EN 60079-29-2 for reference.
- The device is designed to detect gases or vapours in air.
- If a device with a combustible sensor is exposed to vibrations, calibration shall be done in sufficient short intervals until it is verified that the device is not affected by the vibration stress.
- Do not mount the sensing head in direct sunlight as this could cause overheating of the sensor.
- The device must be installed with the sensor inlet pointing downwards to avoid clogging of the gas inlet by particles or liquids.
- Electrochemical sensors are sealed units which contain a corrosive electrolyte. Should a sensor develop leakage, it must be immediately removed from service and disposed of properly. Caution must be exercised so that the electrolyte does not contact skin, clothing or circuitry otherwise personal injury [burns] and/or equipment damage may result.
- The only absolute method to ensure proper overall operation of the device is to check it with a known concentration of the gas for which it has been calibrated. Consequently, calibration checks must be included as part of the routine inspection of the system.
- As with all devices of these types, high levels of, or long exposure to, certain compounds in the tested atmosphere could contaminate the sensor. In atmospheres where the device may be exposed to such materials, calibration must be performed frequently to ensure that the operation is dependable and display indications are accurate.

- The device must not be painted. If painting is done in an area where a device is located, care must be exercised to ensure that paint is not deposited on the sintered metal flashback arrestor in the gas sensor inlet, if so equipped. Such paint deposits would interfere with the gas diffusion -process.
- To ensure proper function the device must be kept dry and free of any contaminants, e.g. dust particles and water. Regular visual checks are recommended. Any contaminants must be removed by blowing them off with clean, oil-free compressed air or with a dry brush. Ensure that the air entrances are kept free from any coating, e.g. paint, grease or similar.
- Use only genuine MSA replacement parts when performing any maintenance procedures provided in this manual. Failure to do so may seriously impair instrument performance. Repair or alteration of the device, beyond the scope of these maintenance instructions or by anyone other than an auto-rised MSA service personnel, could cause the product to fail to perform as designed.
- The device is designed for applications in hazardous areas under atmospheric conditions.
- For correct measurements, the combustible gas sensors require an oxygen concentration greater than 10 Vol%. Oxygen enriched atmospheres, greater than 21 Vol%, can affect the measurement and the electrical safety of the device.
- The response time of the device will be increased by significant dust deposits on the Sensor. Checks for dust deposits must be done at regular intervals.
- Catalytic combustible gas sensors may produce low or zero response to combustible gas after exposure to substances as Silicon, Silane, Silicate, Halide and compounds containing Fluorine, Chlorine, Iodine or Bromine.
- Catalytic sensor: After exposure of gas above the measuring range, the sensor has to be immediately calibrated / adjusted, independent of the calibration interval. In the case of an adjustment the zero point and sensitivity of the sensor has to be rechecked again after 24 hours.
- In case of very high flammable concentrations >100%LEL the device is able to lock all outputs [LOC]. This function shall be used for -standalone applications according to ATEX requirements.
- Catalytic sensor: If the PrimaX is operated in combination with a control unit and [LOC] is deactivated on the PrimaX, the control unit has to ensure the latching after the measuring range was exceeded.
- Catalytic sensor: Before a reset of an over range [LOC] indication is done it shall be verified that the gas concentration is below full scale.
- Toxic gases: If the measuring range is exceeded, sensor life time can be reduced or the sensor might need a recovery phase.
- Used sensors have to be disposed of in an environmentally compatible way.
- At signal underrange (see chapter [11.1 Output States](#)) the 4 - 20 mA output is set to 3.8 mA (or 2.0 mA) and "LO" (alternately Measure Value if suppressing negative values in M-14 is set to "OFF") shown on the display. To avoid a delayed alarm activation, a calibration should be done when the output current is set to 3.8 mA and "LO" is shown on the display persistently.
- The lowest range which is suitable for the alarm thresholds should be selected for toxic gases.
- Recommended working life time of the device: 15 years.
- To compensate for possible deviations during measurement of flammable gases a calibration factor of 1.05 has to be applied when using the CalGard for remote calibration (see chapter [8.3 Remote Calibration](#)).
- Customers using the catalytic combustible gas sensors to detect hydrogen and hydrocarbons in an environment that may contain polar solvents must:
  - Calibrate their sensors with the target gas. Do not use a surrogate gas for calibration.
  - After exposure to polar solvents, the sensor must be recalibrated using the target gas, independent of the calibration interval, and a gas/function check must be performed 24 hours after calibration to verify sensor response and accuracy.

**Failure to follow these warnings can result in serious personal injury or death.**

---

## 1.4 MSA Permanent Instrument Warranty

### Warranty

Seller warrants that this product will be free from mechanical defect or faulty workmanship for

- Gas Transmitter: eighteen [18] months from date of shipment or one [1] year from installation, whichever occurs first;
- Oxygen, Toxic or Catalytic Combustible Sensor: eighteen [18] months from date of shipping or one [1] year from installation, whichever occurs first.

This warranty is applicable provided the product is maintained and used in accordance with Seller's instructions and/or recommendations. This warranty does not apply to expendable or consumable parts, whose normal life expectancy is less than one [1] year.

The Seller shall be released from all obligations under this warranty in the event repairs or modifications are made by persons other than its own or authorized service personnel or if the warranty claim results from physical abuse or misuse of the product. No agent, employee or representative of the Seller has any authority to bind the Seller to any affirmation, representation or warranty concerning the goods sold under this contract. Seller makes no warranty concerning components or accessories not manufactured by the Seller, but will pass onto the Purchaser all warranties of manufacturers of such components.

## 2 Description

### 2.1 Identifying the Unit

#### PrimaX P

flameproof version



#### PrimaX I

general purpose version, or  
intrinsically safe version



Figure 1 PrimaX Gas Transmitter

#### PrimaX P

The PrimaX P is a gas transmitter with an aluminum enclosure. This is a flameproof version for the detection of combustible or toxic gases or oxygen.

#### PrimaX I

The PrimaX I is a gas transmitter with a plastic enclosure. It is available as a general purpose version [not intended for hazardous area] or intrinsically safe version. Both versions are designed for a detection of toxic gases or oxygen.

## 2.2 Overview

The device is factory-calibrated and delivered ready for installation. Each device is configured and calibrated for only one specific gas or vapor.

The enclosures vary depending on the particular version. The electrical parts and interfaces have the same basic functionality.

The device has:

- a quick and easy pluggable sensor,
- a four digit liquid crystal display [LCD],
- a key pad with a cover
- a detachable backplate for installation on a wall or on a pipe

The device operates with a 4 – 20 mA output signal.



Figure 2 Exploded View (PrimaX P)

- |   |                               |    |                            |
|---|-------------------------------|----|----------------------------|
| 1 | Terminal for power connection | 6  | Sensor                     |
| 2 | Keypad with cover             | 7  | Red LED (PrimaX P only)    |
| 3 | Connector for factory use     | 8  | Yellow LED (PrimaX P only) |
| 4 | Display                       | 9  | Green LED (PrimaX P only)  |
| 5 | Bayonet joint with interlock  | 10 | Identification plate       |

### Sensors

Description	PrimaX P	PrimaX I
Detection of toxic gases	X	X
Detection of oxygen	X	X
Detection of combustible gases	X	

The device operates with a 4 – 20 mA output signal.

As an optional feature additional modules are available for these configurations of PrimaX transmitter:

Modules	PrimaX P	PrimaX I
HART module	X	X
HART + Relays module	X	-
HART+ Relays module with galvanically isolated analogue output	X	-

For more information on the HART module → chapter [4.7 Optional HART Module and Relay](#).

## 3 Installation

The device should be installed where gas leaks are expected. The installation position depends on the gas density, either in the upper area of the room under the ceiling for gases lighter than air or close to the ground for gases heavier than air. Also consider how air movement may affect the ability of the device to detect gas. The display on the front of the instrument must always be clearly visible, the view must not be obstructed.



Before beginning the installation, check that the delivered components are not damaged during transportation, complete and correct, including gas sensor, selected measuring range, device settings according general conditions for the safe use (if required, see chapter [7 Approvals](#)) and accessories. Please refer to the shipping documents, label on the device including serial number and the sticker on the shipment carton.



When preparing the assembly, make sure that the mounting arrangement is correct for the particular device.

### 3.1 Mechanical Installation

#### Preparation

To install the device, first remove the backplate.



#### Undo Screws

1. Unscrew the device.

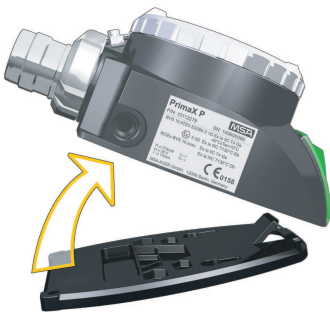

#### Remove Device

2. Remove the device from the backplate by lifting up the lower edge as shown.

#### Wall or Pipe Mounting

For pipe mounting a pipe mounting kit is necessary (→ chapter [8.6 Pipe Mounting Kit](#)).



#### Install the Backplate

1. Use the two keyhole slots for attaching the mounting plate to the wall. Use 6mm diameter screws and suitable plugs.
2. For a wall installation use the backplate as a template for drilling the holes for the two fixing screws, for a pipe installation use the pipe clip.
3. Attach the backplate to the wall or the pipe clip with M6 x 20 screws.
  - a. The hitch should point away from the wall or pipe.
  - b. The straight edge of the backplate should be at the bottom.

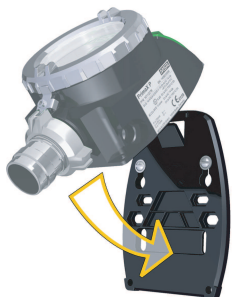

#### Attach the Device to the Backplate

4. Attach the device to the top of the backplate.
5. Fold down the device, till it is closed to the backplate.



#### Fasten Device

6. Screw the device to the backplate.

## 3.2 Electrical Installation

### Instructions for Electrical Connection

#### WARNING!

The device must be installed only in compliance with the applicable -regulations, otherwise the safe operation of the instrument is not-guaranteed.

**Failure to follow this warning can result in serious personal injury or death.**

- Shielded cable for measuring devices is recommended.
- Always observe maximum cable lengths and cross-sections (→ chapter [6.2 Cable Lengths and Cross-sections](#)).
- Water or impurities can penetrate the instrument through the cable. In hazardous areas, it is recommended to install the cable in a loop just before entry into the instrument or to slightly bend it to prevent water from entering.



The power supply is defined as 24 VDC. If the input supply voltage at the terminal of the transmitter is less than 10 V, the device will shut down. The 24 V power supply shall fulfill the requirements for a PELV/SELV of EN 60950.



Operating the PrimaX I version in hazardous areas requires an -intrinsically safe power supply.

#### 3.2.1 Electrical Connection - PrimaX P

##### Terminal PrimaX P

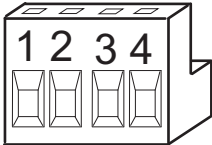

Figure 3 Terminal PrimaX P  
(3-wire sensor)

- |   |                           |
|---|---------------------------|
| 1 | Power supply (+), 24 V DC |
| 2 | 0 V DC                    |
| 3 | 4 – 20 mA (Signal)        |
| 4 | empty                     |

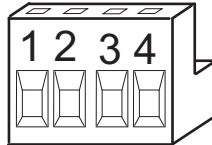

Figure 4 Terminal PrimaX P  
(4-wire sensor)

- |   |                           |
|---|---------------------------|
| 1 | Power supply (+), 24 V DC |
| 2 | 0 V DC                    |
| 3 | 4 – 20 mA (Signal)        |
| 4 | Isolated ground           |

Screw terminals: cross section 0.5 - 2.5 mm<sup>2</sup>, screw torque 0.55 Nm ± 0.05 Nm

##### PrimaX P



Figure 5 3-wire/4-wire connection - PrimaX P

- |   |                          |   |  |
|---|--------------------------|---|--|
| 1 | Power supply (+) 24 V DC | 4 | Isolated ground  |
| 2 | 0 V DC (-)               | 5 | Ground terminal: 5x10 mm Hexagon, torque 4 Nm ± 0.5 Nm |
| 3 | 4 – 20 mA (Signal)       |   |  |

1. Unscrew the interlock between cover and bayonet joint of sensor.
2. Unscrew the aluminum lid of the enclosure.
3. Unplug the 4-way terminal block.

*The block is located behind a plastic cover above the display.*

4. Unscrew clamping nut at the cable gland.
5. Put clamping nut on the cable.
6. Insert cable for connection into the device.
7. Connect cable to terminal.

*Use a shielded cable with 3 wires for the 3-wire sensor.*

*Use a shielded cable with 4 wires for the 4-wire sensor.*

8. Tighten cable gland clamping nut, check that cable cannot move within the cable gland.
9. Replace enclosure lid and secure the interlock.

### 3.2.2 Electrical Connection - PrimaX I

#### Terminal PrimaX I

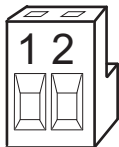

Figure 6 Terminal PrimaX I

- 1 Power supply (+), 24 V DC
- 2 4 – 20 mA (Signal)

Screw terminals: cross section 0.5 - 2.5 mm<sup>2</sup> screw torque 0.55 Nm ±0.05 Nm

#### PrimaX I



Figure 7 2-wire connection - PrimaX I

- 1 Power supply (+)
- 2 4 – 20 mA (Signal)

1. Remove plastic cover.  
*It is bolted with 4 screws.*
2. Remove the 2-way terminal block.  
*It is located behind a plastic cover above the display.*
3. Unscrew clamping nut at the cable gland.

### 3 Installation

---

4. Put clamping nut on the cable
5. Insert cable for connection into the device.
6. Connect cable to terminal.
  - a. Use a 2-wire shielded cable.
7. Tighten cable gland clamping nut, check that cable cannot move within the cable gland.
8. Replace plastic cover, tighten the screws and secure the interlock.

## 4 Operation



The device is factory-calibrated and delivered ready for installation. Each device is configured and calibrated for only one specific gas or vapor.

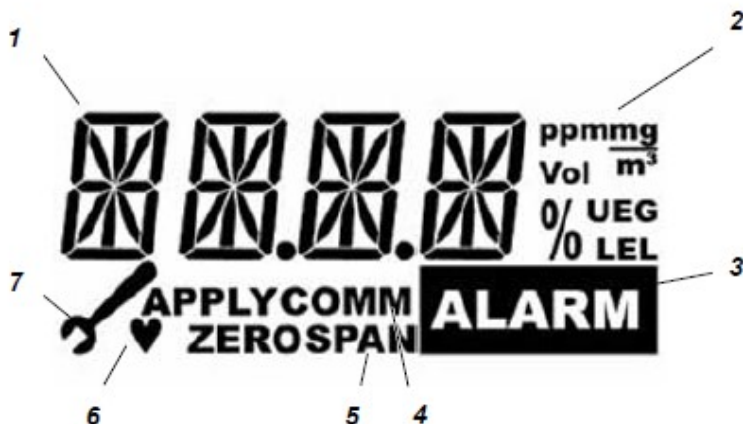

Figure 8 Display overview

1	Measuring value/Menu//Text dimensions	5	Calibration
2	Units	6	Alive signal [flashing]
3	LOC, alarm indication [optional]	7	Maintenance
4	Signal for an active communication		

### 4.1 Startup

During startup a self-test is performed and the output signal is set to the service current [default 3.0 mA]. The following information is displayed:

#### Display Test

The display shows all segments.

**Note:** The PrimaX P also shows all LEDs and afterwards the yellow LED is flashing during the startup procedure.

#### Software Version

The display shows the firmware version.

#### Sensor

The display shows the configured type of sensor operating with each individual detector, e.g.: COMB [combustible], CO, H<sub>2</sub>S.

#### Range

The display shows the measuring range predefined for the gas detector, e.g.: 100% LEL.

#### Countdown

The countdown for sensor stability is displayed, see "Warm up time" in chapter [6.3 Performance Specifications](#).

#### Normal Operation

After countdown, the gas concentration [ppm, Vol%, % LEL, % UEG, mg/m<sup>3</sup>] is displayed. The heart symbol flashes to indicate alive status.

## 4.2 Menu Sequence

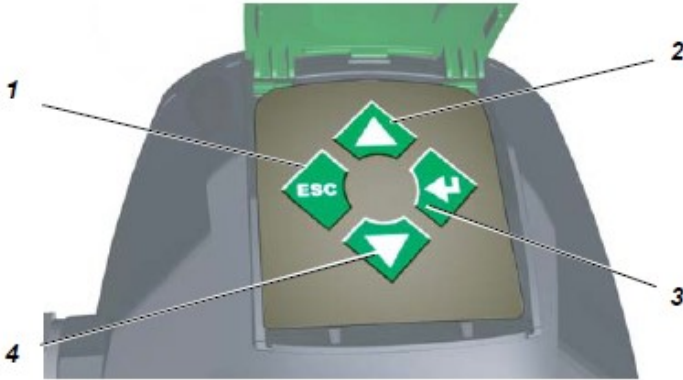

Figure 9 Keypad - operating buttons

- |   |            |   |              |
|---|------------|---|--------------|
| 1 | ESC button | 3 | ENTER button |
| 2 | UP button  | 4 | DOWN button  |

To navigate in the menu sequence, 4 buttons are available.

In general:

1. Press ENTER to get access to a menu sequence.
2. Press UP or DOWN until the desired menu is displayed.
3. Press ENTER to get access to a menu.
4. Press ESC to cancel the process.

The following table lists the menu items. Detailed descriptions can be found in the chapters [4.3 Calibration](#), [4.4 Maintenance and Info](#) and [4.5 Password](#).

Menu item	Text	Password?
M-01	<b>Calibration</b>	Yes
M-02	<b>ZERO Calibration</b>	Yes
M-03	<b>Show Test Gas Concentration</b>	No
M-04	<b>Setup Calibration</b>	Yes
M-05	<b>Sensor Exchange</b>	Yes
M-06	<b>LCD and LED Test</b>	No
M-07	<b>Loop Test</b>	Yes
M-08	<b>Device Info</b>	No
M-09	<b>Sensor Info</b>	No
M-10	<b>Changing the Range</b>	Yes
M-14	<b>Deadband (Zero window)</b>	Yes
M-00	<b>Reset Alarm</b>	Yes

## 4.3 Calibration



### WARNING!

The test gases used for calibration are possibly posing a health risk. Proper ventilation or extraction has to be ensured.

**Failure to follow this warning can result in serious personal injury or death.**

#### General

The calibration must be done at regular intervals in accordance with applicable national and regional regulations.

The device is calibrated at the factory. Nevertheless, it is recommended to re-calibrate the device after installation and perform a functional check/calibration check at least quarterly. The frequency of calibration depends on the duration of use and the chemical exposure of the sensor. New sensors must be recalibrated frequently until it is clear from the calibration data that they have stabilised. Suitable regulators and pipes for calibration must be used. A visual check of all components has to be done regularly to be able to detect damages, failures or blockages. Sensor EOL (End of life): For general purpose applications the sensor has to be replaced if the calibration fails due to low sensor sensitivity (sensor lifetime counter).

In case of high dust or water pollution is expected then the calibration intervals should be shortened.

Exposure to polar solvents may reduce the catalytic combustible gas sensors response to hydrogen and hydrocarbons resulting in erroneously low readings for hydrogen and hydrocarbons. Calibration of the sensors with a surrogate gas will not detect the reduction in response. Customers using the catalytic combustible gas sensors to detect hydrogen and hydrocarbons in an environment that may contain polar solvents must:

- Calibrate their sensors with the target gas. Do not use a surrogate gas for calibration.
- After exposure to polar solvents, the sensor must be recalibrated using the target gas, independent of the calibration interval, and a gas/function check shall be performed 24 hours after calibration to verify sensor response and accuracy.



- A calibration cap is recommended for sensor calibration.
- Connect power to the device at least one hour before attempting a calibration.
- Carry out the calibration during commissioning as well as at regular intervals. This ensures optimum operation of the sensor.
- It is recommended that all calibration components are connected before starting a calibration as it is necessary to apply test gas to the device during a countdown.
- When monitoring flammable gas in safety related applications the -PrimaX must be calibrated with a known concentration of the gas being monitored.

The lower explosive limits (LEL) of the gases and vapors in the following example were taken from EN 60079-20-1. Local regulations may specify different LEL values; always ensure the correct values are used.

It is recommended that the PrimaX zero is calibrated using clean air, free of measuring gas, and calibration gas of approximately 50 % of measuring range (comb. and TOX) in air of the gas being monitored. The recommended calibration gas for oxygen is 50% of measuring range, but for a measuring range 0-25 vol% O<sub>2</sub>, the device can be calibrated using 20.9 vol% O<sub>2</sub>.

For calibration a test gas cylinder can be used.



The application time of dry calibration gas (< 15% rel. humidity) to the electrochemical sensors shall not exceed 15 minutes.



For oxygen a zero calibration with gas [M-02] is not required, it is performed internally.

### Calibration example for Methanol

Methanol calibration gas concentration being used	=	3,5 Vol%
Methanol volume concentration for 100%LEL	=	6,0 Vol%

Methanol calibration gas concentration in %LEL

$$3,5 \text{ Vol\% CH}_4\text{O} \times \frac{100\% \text{ LEL}}{6,0 \text{ Vol\% CH}_4\text{O}} = 58,3 \text{ \% LEL}$$

### Calibration Procedure

The calibration can be performed as a manual or an automatic calibration [→ M-04].

**Automatic Calibration [automatic]:** a countdown is displayed. After the countdown the value is measured and displayed. When the value is stable the current value is selected automatically.

**Manual Calibration [manual]:** the measuring value is displayed. When the value is stable press ENTER to select the current value. For typical applications the recommended test gas application time is:  $t_{\text{Test gas}} = 5 * t_{90\text{Gas}}$ , depending on the test gas, see chapter [6.4 List of Detectable Gases and Response Time](#).

### Waiting for calibration gas

After starting any calibration step, calibration gas [zero or test gas] must be applied until calibration step is finished. The time taken to reach stable indication (change of measuring value < 1% of the measuring range within 15 seconds) and finishing calibration step can be measured with a stopwatch.



The calibration state is indicated by the output signal current and has to be monitored in case of manual calibration (→ chapter [7.3 Special conditions for the safe use according to ATEX, EN 50104, and SIL applications](#)).

---

### Calibration Steps



The calibration procedure can be canceled at any time by pressing ESC. The previous transmitter calibration will be used.

---

### (M-01) - ZERO and SPAN Gas Calibration

1. Press ENTER and select menu 1.
2. Press ENTER button.
3. Enter password (→ chapter [4.5 Password](#)).
4. Apply zero gas (synthetic air).
5. Wait until countdown is finished (automatic) or press ENTER (manual).

*OK is displayed.*

6. Apply test gas.
7. Wait until calibration is finished (automatic) or press ENTER (manual).

*OK is displayed.*

*Idle time countdown starts, during this time the test gas can be removed and the output signal remains on service current level.*

8. Remove test gas during the countdown.

**[M-01] - Oxygen Calibration**

1. Press ENTER and select menu 1.
2. Press ENTER button.
3. Enter password (→ chapter 4.5 Password).
4. Apply synthetic air.
5. Wait until countdown is finished (automatic) or press ENTER (manual).  
*OK is displayed.*
6. The device goes to measuring mode.

**[M-02] - ZERO Gas Calibration**

7. Press ENTER and select menu 2.
8. Press ENTER button.
9. Enter password (→ chapter 4.5 Password).
10. Apply zero gas (synthetic air).
11. Wait until calibration is finished (automatic) or press ENTER (manual).  
*OK is displayed.*
12. The device goes to measuring mode.

**4.4 Maintenance and Info****[M-03] - Show Test Gas Value**

1. Press ENTER and select menu 3.
2. Press ENTER button.  
*Test gas concentration is displayed.*
3. Press ENTER button to go back to Menu or ESC to go back to measuring mode.

**[M-04] - Setup Calibration**

This menu is used to set the test gas concentration for span calibration and all calibration countdown times.

1. Press ENTER and select menu 4.
2. Press ENTER button.
3. Enter password [→ chapter 4.5 Password].
4. Set the test gas concentration with the UP or DOWN button.
5. Press ENTER button.
6. Set the zero calibration countdown time in seconds with the UP or DOWN button.
  - a. **Note:** time = MAN → [manual] zero calibration, otherwise an [automatic] calibration is performed by the device.
7. Press ENTER button.
8. Set the span calibration countdown in seconds with the UP or DOWN button.
  - a. **Note:** time = MAN → [manual] span calibration, otherwise an [automatic] calibration is carried out by the device.
9. Press ENTER button.
10. Set the idle time countdown in seconds with the UP or DOWN button.
11. Press ENTER button.

**[M-05] - Sensor Exchange**

This menu initiates the initial calibration and resets the sensor lifetime counter. OX/TOX sensors can be exchanged under power [hot swapped] with this function.

**⚠ WARNING!**

Hot swaps must not be carried out for COMB sensors.

Only OX/TOX sensors can be exchanged with this menu.

For COMB sensors with this menu only the initial calibration is initiated and the sensor life time is reset.

**Failure to follow this warning can result in serious personal injury or death.**

If an [OX/TOX] sensor is connected:	If a COMB sensor is connected:
<ol style="list-style-type: none"> <li>1. Press ENTER and select menu 5.</li> <li>2. Press ENTER button.</li> <li>3. Enter password [→ chapter 4.5 Password].</li> </ol>	<ol style="list-style-type: none"> <li>1. Press ENTER and select menu 5.</li> <li>2. Press ENTER button.</li> <li>3. Enter password [→ chapter 4.5 Password].</li> </ol>
<ul style="list-style-type: none"> <li>• An hourglass symbol is shown to signify the time span [max. 15 min] during which it is possible to hot-swap a sensor without triggering an error code</li> </ul>	
<ol style="list-style-type: none"> <li>5. Change the sensor during this time span.</li> <li>6. Press ENTER or ESC to start the running-in time countdown.</li> <li>7. [Perform a ZERO and SPAN or Oxygen calibration [M-01].</li> </ol>	<ol style="list-style-type: none"> <li>4. [Perform a ZERO and SPAN -calibration [M-01].</li> </ol>



Sensors that are no longer required have to be disposed of in an environmentally compatible way.

**[M-06] - LCD/LED Test**

LCD and LED test [LED only available in PrimaX P]. All segments will be displayed and the LEDs will flash sequentially.

1. Press ENTER and select menu 6.
2. Press ENTER button.

**[M-07] - Loop Test**

In this menu a 4 - 20 mA loop test will be performed.

1. Press ENTER and select menu 7.
2. Press ENTER button.
3. Enter password [→ chapter 4.5 Password].  
*The loop test mA value is displayed [default value = 12 mA].*
4. Press UP or DOWN to change the value.
5. Press ENTER button to start the test.
6. Press ENTER button to go back to menu or ESC to go back to measuring mode.

**[M-08] - Device Information**

In this menu device information is shown, i.e. gas type, measuring range, firmware version.

1. Go through the information with the ENTER button.

**[M-09] - Sensor Information**

This menu shows the minimum and maximum measured gas concentrations, which can be reset by holding the UP or DOWN button.

It shows the sensor life time in months since sensor exchange [→ M-05].

If a COMB or a TOX sensor is connected this menu shows the response time [as calculated during zero span calibration].

If an OX/TOX sensor is connected this menu shows the measured mV value.

If a COMB sensor is connected this menu shows the detector [U<sub>D</sub>], compensator [U<sub>K</sub>] and differential voltage [U<sub>X</sub>] in mV.

1. Go through the information with the ENTER button.

#### [M-10] - Range Selection



#### WARNING!

Test gas concentration has to be checked and device has to be calibrated if the range is changed.  
**Failure to follow this warning can result in serious personal injury or death.**

This menu allows to set up the optional measuring ranges for connected OX/TOX sensors.

1. Press ENTER and select menu 10.
2. Press ENTER button.
3. Enter password [→ chapter 4.5 Password].
4. Press UP or DOWN button to select the range and/or the measuring unit [OX: Vol%, TOX: ppm, mg/m<sup>3</sup>; COMB: LEL, UEG].
5. Press ENTER button.

*OK is displayed.*

*The calibration is set to invalid and service current is supplied until recalibrated.*

#### [M-14] - Deadbands

Menu for suppressing negative values and enable/disable the deadband (zero window).

1. Press ENTER and select menu 14.
2. Press ENTER button.
3. Enter password [→ chapter 4.5 Password].
4. Setting for suppressing negative values.
5. Set ON or OFF with the UP or DOWN button [default value = ON].
6. Press ENTER button.
7. Setting for zero window appears (values within -2% – 2% of range are set to zero/4 mA).
8. Set ON or OFF with the UP or DOWN button [default value = ON].
9. Press ENTER button.

#### [M-00] - Reset Alarm

Menu to reset a LOC of combustible sensor or an alarm. It appears only in the menu if there is a latched LOC or alarm.

**NOTE:** Before a reset of an over range (LOC) indication is done it shall be verified that the gas concentration is below full scale.

1. Press ENTER and select menu 0.
2. Press ENTER button.
3. Enter password [→ chapter 4.5 Password].  
*Success message confirms that latched alarm is reset.*

## 4.5 Password

Menus which should only be changed by qualified and authorized persons are locked by a four digit password.



The default password is 0000.

After entering the password menu, the values of the digits will be set from left to right:

1. Press UP or DOWN to change the value.  
*The value will be increased or decreased.*
2. Press ENTER to get to the next digit.  
*With ESC, one digit can be backspaced.*

If all four digits are entered, the password will be validated.

## 4.6 Changeable Parameters

Values	default	minimum	maximum
Span/Test Gas Value	regarding sensor [e.g.: CO = 60ppm, H <sub>2</sub> S 10ppm, O <sub>2</sub> = 20.8 vol%, combustible = 50% LEL]	10% of Range	100% of Range
Zero Calibration Time	30 s	MAN	2000 s
Span Calibration Time	30 s	MAN	2000 s
Idle Time after calibration	30 s	10 s	2000 s
Range	See <a href="#">6.4 List of Detectable Gases and Response Time</a>		
Loop Test	12 mA	2 mA (PrimaX I) 0 mA (PrimaX P)	22 mA
Suppress negative values	ON	ON	OFF
Zero Window	ON	ON	OFF
Password	0000	0000	9999

## 4.7 Optional HART Module and Relay

### 4.7.1 HART

#### Introduction

"HART" is an acronym for Highway Addressable Remote Transducer. The HART Protocol makes use of the Bell 202 Frequency Shift Keying [FSK] standard to superimpose digital communication signals at a low level on top of the 4 - 20 mA.

The HART Protocol provides two simultaneous communication channels: the 4 - 20 mA analog signal and a digital signal. The 4 - 20 mA signal communicates the primary measured value [in the case of a field instrument] using the 4 - 20 mA current loop. Additional device information is communicated using a digital signal that is superimposed on the analog signal.

PrimaX is registered with the HART foundation and can be accessed at <http://www.hartcomm.org/>

The device is available with an optional HART module or a module with HART and Relays for alarm and failure. It uses the HART Protocol Revision 7 and can only communicate with HART Masters who support revision 7 or higher.



The following HART functions are also available:

ZERO SPAN Calibration / Oxygen Calibration; ZERO Calibration; Sensor Exchange; LCD/LED Test; Loop Test; Range setup; Reset alarm; Readout all measured data and information.

## 4.7.2 Electrical installation



Figure 10 HART ports

1 Optional HART port

For wiring diagrams → chapter [11.6 Wiring Diagrams](#).

## 4.7.3 Relays



Figure 11 Location of Relay

1 Relay Terminals

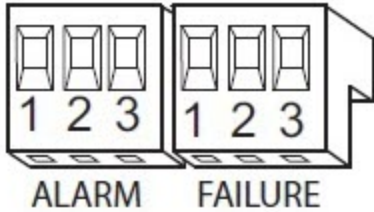

Figure 12 Relay Terminals

*Alarm Relay*

- 1 Normally closed energised[NC]
- 2 Common [COM]
- 3 Normally open energised[NO]

*Failure Relay*

- 1 Normally closed energised[NC]
- 2 Common [COM]
- 3 Normally open energised[NO]

Screw terminals: cross section 0.5 - 2.5 mm<sup>2</sup>, screw torque 0.55 Nm ±0.05 Nm

## 4.8 Relay Operation

### 4.8.1 Startup

If relays are used the alarm threshold will be displayed at startup

### 4.8.2 Menu Sequence

Menu item	Text	Password?
M-11	Relay Info	No
M-12	Relay Setup	Yes
M-13	Relay Test	Yes

#### [M-11] - Relay Info

1. Press ENTER and select menu 11.
2. Press ENTER button.
3. Go through the information with the ENTER button.

It shows:

- The alarm threshold and if the alarm is activated with a rising or falling gas concentration.
- if an alarm would be latched.
- the alarm relay delay time in seconds.
- if the alarm relay is normally energised.
- the failure relay delay time in seconds.
- if the failure relay is normally energised.

#### [M-12] - Relay Setup

1. Press ENTER and select menu 12.
2. Press ENTER button.
3. Enter password [→ chapter 4.5 Password].
4. Set the alarm threshold with the UP or DOWN button.
5. Press ENTER button.
6. Set rising or falling alarm option with the UP or DOWN button.
7. Press ENTER button.

8. Set if latched with the UP or DOWN button.
9. Press ENTER button.
10. Set the alarm relay delay with the UP or DOWN button.
11. Press ENTER button.
12. Set alarm relay normally energised option with the UP or DOWN button.
13. Press ENTER button.
14. Set the failure relay delay with the UP or DOWN button.
15. Press ENTER button.
16. Set the failure relay normally energised option with the UP or DOWN button.
17. Press ENTER button.

#### [M-13] - Relay Test

1. Press ENTER and select menu 13.
2. Press ENTER button.
3. Enter password [→ chapter 4.5 Password].
4. The relays are now Switched and can be tested.
5. Press ENTER button to go back to menu or ESC to go back to measuring mode.

#### Changeable Parameters for Relays

Values	default	minimum	maximum
Alarm threshold	30% of Range [O <sub>2</sub> (25 vol%): 20 vol%]	5 % of Range	100% of Range
Alarm relay normally energised	normally energised	normally energised	normally deenergised
Latch alarm	yes	yes	no
Alarming direction	rising ↗ [O <sub>2</sub> (25 vol%) falling ↘]	rising ↗	falling ↘
Alarm delay time	0 s	0 s	600 s
Failure relay normally energised	normally energised	normally energised	normally deenergised
Failure relay delay time	0 s	0 s	600 s

Settings required for ATEX conditions and EN 50104 applications:



- Latch alarm = yes ( Alarm output self-retaining)
- Failure relay: normally energised
- Failure relay delay time: 0s (no delay of output)

#### Changeable Parameters with HART



For all parameters which can be changed over keypad see chapter 4.6 [Changeable Parameters](#)

Values	default	minimum	maximum
Password	0000	0000	9999
Tag	MSA	-	-
Description	PrimaX	-	-
Long tag		-	-
Message		-	-



In case of very high flammable concentrations >100%LEL the device is able to lock all outputs [LOC]. This function shall be used for -standalone applications according to ATEX requirements.

### Output States

State	Failure Relay	Alarm Relay
Normal		
Startup	Startup state [default: switched]	
Calibration		
Latched voltage overrange	Switched	
Loop not connected	Switched	
Underrange	Switched	
Error	Switched	
Safety critical error	Switched	
LOC [combustible]		Switched
Latched LOC [combustible]		Switched
Alarm threshold exceed		Switched

Switched: the relay state has switched from the normal state. The normal state can be set to energised if alarm/failure or de-energised if alarm/failure. Normally de-energised if alarm/failure meets the ATEX and SIL requirements. In case of switched relays the device will go to the normal state when the related condition [non-latched alarm and/or fail] has been removed.

LOC: The PrimaX Gas Monitor has been exposed to a high gas concentration [above the LEL], and the over-range condition still exists.

Latched LOC: The PrimaX Gas Monitor has been exposed to a high gas concentration [above the LEL], and there is a possibility that the over-range condition may still exist.

For additional information about output states, see chapter [11 Appendix](#)

## 5 Maintenance

### 5.1 Changing the Sensors

#### DANGER!

Remove and reinstall sensors carefully, ensuring that the components are not damaged; otherwise the approval may be adversely affected, wrong readings could occur, and persons relying on this product for their safety could sustain serious personal injury or death.

**Failure to follow this warning will result in serious personal injury or death.**



Before changing the sensor, the Sensor Exchange mode must be activated. This ensures the sensor must be calibrated after exchange and the sensor lifetime counter is reset. See chapter [4.2 Menu Sequence](#).

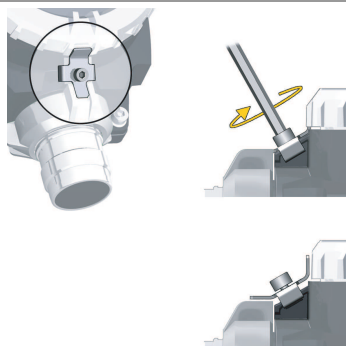

#### Remove Interlock

1. Unscrew the socket head screw.
2. Remove the interlock.

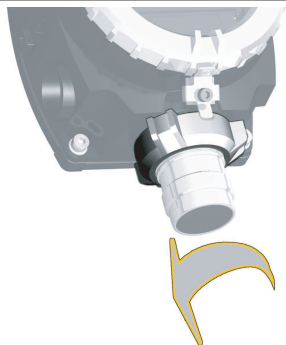

#### Remove Bayonet Joint

3. Turn the bayonet ring counter-clockwise.
4. Remove the bayonet ring by pulling it down.

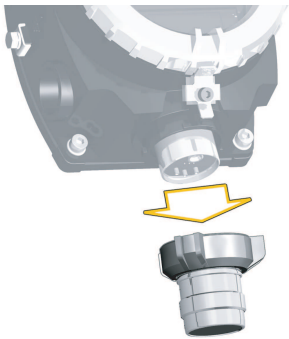

### Replace Sensor

5. Unplug the sensor carefully.
6. Plug in the new sensor carefully.
7. Replace the bayonet ring.
8. Replace the interlock.

## 6 Technical Data

### 6.1 Specifications

	PrimaX P	PrimaX I
<b>Enclosure</b>	aluminum enclosure flameproof IP 67 ingress protection	plastic enclosure intrinsically safe IP 66 ingress protection
<b>Dimensions</b> in mm [Height X Width X Depth]	220 X 162 X 100	220 X 162 X 81
<b>Weight</b>	1.6 kg	1.2 kg
<b>Humidity</b>	15 % to 90 % rel. humidity	15 % to 90 % rel. humidity
<b>Power supply</b>	19.2 V - 28.0 V	19.2 V - 28.0 V
<b>Power consumption</b>	3 W	0.7 W
<b>Temperature range [instrument]*</b>	-40 to +70 °C	-40 to +70 °C
<b>Temperature range [sensor]*</b>	see <a href="#">6.4 List of Detectable Gases and Response Time</a>	see <a href="#">6.4 List of Detectable Gases and Response Time</a>
<b>Signal output</b>	4 – 20 mA	4 – 20 mA
<b>Transfer function</b>	Linear, 0-100% FSD	Linear, 0-100% FSD
<b>HART [option]</b>	yes	yes
<b>Relay [option]</b>	yes	no
<b>Signal output tolerance</b>	1 %	1 %
<b>Pressure**</b>	80 – 120 kPa	80 – 120 kPa
<b>Max. load resistance</b>	300 Ohm	300 Ohm
<b>Air velocity**</b>	0 – 6 m/s	0 – 6 m/s

\* Temperature range of device defined by lower value of [instrument] or [sensor].

\*\* Measuring function tested according to EN 60079-29-1 and EN 50104, pressure up to 120 kPa, higher values may result in higher deviation of the gas reading.

#### Measuring Methods

Oxygen	Electrochemical sensor
Toxic gases	Electrochemical sensor
Combustible gases	Thermo-catalytic sensor

Relay nominal switching capacity [resistive load]:

Alarm Relay	min. 10 mA / 10 V DC max. 2 A / 30 V DC
Failure Relay	min. 10 mA / 10 V DC max. 2 A / 30 V DC



The specified IP protection class does not imply that the unit is capable of measuring under all environmental conditions, for details see chapter [1.3 Safety and Precautionary Measures to be Adopted](#).

**Refresh Rate of Output Signals (Maximum delay time until special output state is entered)**

4 - 20 mA output signal [analog]	100 ms
Alarm [LED and relay]	100 ms
Failure [LED and relay]	100 ms
Display [measuring value]	1 s
Display [alarm]	2100 ms

**6.2 Cable Lengths and Cross-sections**

The maximum load resistance for all combinations is 300 Ohm.

Sensor type	Cross-section	Max. length at 24 V DC	
		without relay	with relay
Toxic Gases and Oxygen Sensors with 4 – 20 mA Signal Output [2- wire Sensor]	1.0 mm <sup>2</sup>	1960 m	
	1.5 mm <sup>2</sup>	2940 m	
Catalytic Combustible Gas Sensor with 4 – 20 mA Signal Output [3- wire Sensor]	1.0 mm <sup>2</sup>	980 m	700 m
	1.5 mm <sup>2</sup>	1470 m	1050 m
Toxic Gases and Oxygen Sensors with 4 – 20 mA Signal Output [3- wire Sensor]	1.0 mm <sup>2</sup>	3920 m	2000 m
	1.5 mm <sup>2</sup>	5880 m	3000 m
Catalytic Combustible Gas Sensor with 4 – 20 mA Signal Output [4- wire Sensor]	1.0 mm <sup>2</sup>		420 m
	1.5 mm <sup>2</sup>		630 m
Toxic Gases and Oxygen Sensors with 4 – 20 mA Signal Output [4- wire Sensor]	1.0 mm <sup>2</sup>		1848 m
	1.5 mm <sup>2</sup>		2772 m

**6.3 Performance Specifications**

Warm up time	Combustible	95 s
	OX/TOX	36 s
Storage range (device and accessories, unless otherwise noted)		Temperature -40 °C to +70 °C or temperature range of the sensors or CalCap at 15 % to 90 % rel. humidity Pressure 80 -120 kPa
Nominal orientation and orientation limits		vertical ± 15° (sensor downwards)
Deadband if enabled, measured values within the limits are indicated as zero (zero window)		0 ± 2% FS

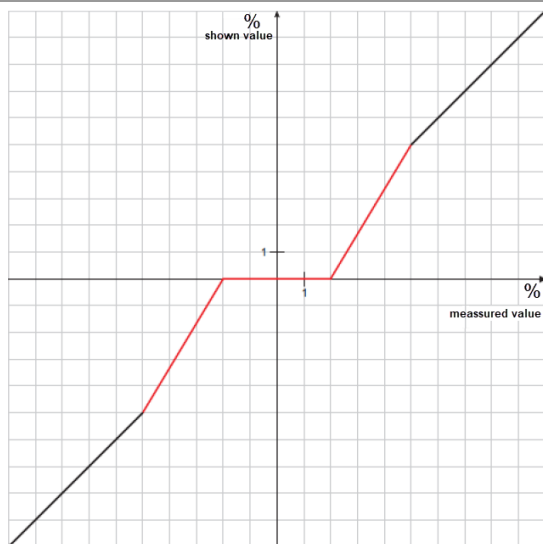

The device is calibrated at the factory and the sensor life time is started. Please keep the storage time short (< 3 months) for best performance of the sensors.

## 6.4 List of Detectable Gases and Response Time

Gas	Default range	Selectable range[s]	Temperature Range
Ammonia [NH <sub>3</sub> ]	100 ppm	50 ppm	-20 – 40 °C
Ammonia [NH <sub>3</sub> ]	500 ppm	1000 ppm	-20 – 40 °C
Carbon Monoxide [CO]	200 ppm	100 ppm 500 ppm 1000 ppm	-20 – 50 °C
Chlorine [Cl <sub>2</sub> ]	10 ppm	5 ppm	-20 – 40 °C
Hydrogen [H <sub>2</sub> ]	1000 ppm	-	-20 – 50 °C
Hydrogen Chloride [HCl]	30 ppm	10 ppm 20 ppm	-20 – 40 °C
Hydrogen Cyanide [HCN]	30 ppm	10 ppm 20 ppm 50 ppm	-40 – 40 °C
Hydrogen Sulphide [H <sub>2</sub> S]	50 ppm	10 ppm 20 ppm 100 ppm	-40 – 50 °C
Methane [CH <sub>4</sub> ]*	100 % LEL	-	-40 – 70 °C
Nitric Oxide [NO]	100 ppm	-	-15 – 40 °C
Nitrogen Dioxide [NO <sub>2</sub> ]	10 ppm	20 ppm 100 ppm	-20 – 50 °C
Oxygen [O <sub>2</sub> ]*	25 vol. %	10 vol. %	-30 – 55 °C
Propane [C <sub>3</sub> H <sub>8</sub> ]*	100 % LEL	-	-40 – 70 °C
Sulphur Dioxide [SO <sub>2</sub> ]	50 ppm	10 ppm 20 ppm 100 ppm	-20 – 50 °C

\* Extended range: The sensor extended temperature range is greater than the maximum specified in EN 60079-29-1 and EN 50104. The requirements of these standards are met over the full temperature range.

Gases	Zero drift	Full scale drift	Zero deviation	Lower limit of the measurement
CO	≤ 2 ppm/month	≤ 5 %/month	≤ 4 % of full scale	3 % of full scale
H <sub>2</sub> S	≤ 2 ppm/month	≤ 5 %/month	≤ 2 % full scale, at least 1 ppm	1 % full scale, at least 1 ppm

Gas	Drift
O <sub>2</sub>	≤ 1 % / 3 months

### Resolution of display

#### Measuring range Resolution

1 to 10	0.1
25 Vol % oxygen	0.1
10 to 2000	1

**PrimaX Response Time**

**NOTE:** The Response time refer to an ambient temperature of 20 °C and depends on environmental parameters, i.e. temperature, humidity, flowrate, etc. The time of response of the entire system is determined by the time of response of all parts of equipment within the gas detection system.

**PrimaX Response Time (diffusion mode without any accessories)**

Oxygen			Recovery time
	t20	t90	t10
	≤8 s	≤ 25 s	≤ 25 s

Toxic	Response time		Recovery time	
	t50	t90	t50	t10
CO	≤15s	≤140 s	≤ 9 s	≤70 s
H <sub>2</sub> S	≤4 s	≤64 s	≤ 5 s	≤ 85 s

Combustible			Recovery time	
	t50	t90	t50	t10
Methane	≤ 10 s	≤ 18 s	≤ 10 s	≤ 18 s
Propane	≤ 12 s	≤ 20 s	≤ 12 s	≤ 20 s

**PrimaX Response time (with calibration cap, flow rate 1 l/min)**

Combustible			Recovery time	
	t50	t90	t50	t10
1-Ethoxy-2-Propanol	≤ 24 s	≤ 85 s	≤ 24 s	≤ 85 s
Hydrogen	≤ 7 s	≤ 13 s	≤ 7 s	≤ 13 s
Methane	≤ 8 s	≤ 14 s	≤ 8 s	≤ 14 s
Propane	≤ 8 s	≤ 15 s	≤ 8 s	≤ 15 s



The response time t90 will be increased up to 70 seconds by using the Sensor gard.

**6.5 Sensor Response to Interferants**

Interference factors may differ from sensor to sensor and with life time.

It is not advisable to calibrate with interference gases.

This table does not claim to be complete. The sensor might also be sensitive to other gases.

Gas Sensor	Interferant		
Combustible	wide variety of combustible gases and vapours		
Ammonia [NH <sub>3</sub> ] 100 ppm	20 ppm H <sub>2</sub> S 2 ppm		
Ammonia [NH <sub>3</sub> ] 1000 ppm	30 ppm Cl <sub>2</sub> 5 ppm	200 ppm H <sub>2</sub> S 120 ppm	10 ppm NO <sub>2</sub> 6.5 ppm

Gas Sensor	Interferant		
	200 ppm SO <sub>2</sub> -20 ppm		
Carbon Monoxide [CO]	100 ppm NO 69 ppm	100 ppm H <sub>2</sub> 40 ppm	100 ppm ethanol 4 ppm
	100 ppm NO <sub>2</sub> -5 ppm		
Chlorine [Cl <sub>2</sub> ]	1 ppm Br <sub>2</sub> 1 ppm	2.4 ppm ClO <sub>2</sub> 0.55 ppm	20 ppm H <sub>2</sub> S 0.1 ppm
	10 ppm NO <sub>2</sub> 4.5 ppm	0.25 ppm O <sub>3</sub> 0.11 ppm	
Hydrogen [H <sub>2</sub> ]	300 ppm CO <60 ppm	15 ppm H <sub>2</sub> S <3 ppm	35 ppm NO 10 ppm
	10 ppm HCN 3 ppm	100 ppm C <sub>2</sub> H <sub>4</sub> 80 ppm	
Hydrogen Chloride [HCl]	0.2 ppm AsH <sub>3</sub> 0.7 ppm	5 ppm Cl <sub>2</sub> < +/- 0.1 ppm	20 ppm HCN 7 ppm
	20 ppm H <sub>2</sub> S 60 ppm	100 ppm NO 45 ppm	10 ppm NO <sub>2</sub> < +/- 0.5 ppm
	0.1 ppm PH <sub>3</sub> 0.3 ppm	20 ppm SO <sub>2</sub> 8 ppm	
Hydrogen Cyanide [HCN]	100 ppm NO -5 ppm	10 ppm NO <sub>2</sub> -7 ppm	
Hydrogen Sulphide [H <sub>2</sub> S]	100 ppm Cl <sub>2</sub> -9 ppm	100 ppm NO <sub>2</sub> -21 ppm	100 ppm NO 1 ppm
	100 ppm HCN 1 ppm	100 ppm SO <sub>2</sub> 1 ppm	
Nitric oxide [NO]	20 ppm HCN 5 ppm	10 ppm NO <sub>2</sub> 3.5 ppm	20 ppm SO <sub>2</sub> 6 ppm
Nitrogen Dioxide [NO <sub>2</sub> ]	50 ppm NO <-5 ppm	20 ppm SO <sub>2</sub> <-15 ppm	10 ppm Cl <sub>2</sub> <80 ppm
	400 ppm H <sub>2</sub> <0.1 ppm	20 ppm H <sub>2</sub> S <-35 ppm	400 ppm CO <0.1 ppm
	20 ppm NH <sub>3</sub> < 0.1 ppm	50 ppm C <sub>2</sub> H <sub>4</sub> < 0.1 ppm	5 vol% CO <sub>2</sub> < 0.1 ppm
	200 ppb O <sub>3</sub> <120 ppm		
Oxygen [O <sub>2</sub> ]	no data		
Sulphur Dioxide [SO <sub>2</sub> ]	300 ppm CO <3 ppm	5 ppm NO <sub>2</sub> -5 ppm	

## 6.6 PrimaX P List of Combustible Gases and Vapours detectable with Catalytic Sensor P/N 10112716

### Relative response factors of tested gases with reference to Propane

For the gases or vapours shown in the tables of this chapter the response curves have been tested according to EN 60079-29-1:2016. If the LEL of a substance was not listed in EN 60079-20-1:2010, the LEL has been taken from the Chemsafe data base (Dechema, Frankfurt). Due to legal requirements other locally used LEL values might be mandatory. It is highly recommended that the gas detector is exposed to clean air when calibrating the zero and a mixture of the target gas in air with a concentration of approximately 50% LEL. If calibration with the target gas is not possible a reference calibration can be performed with 0.85 % (v/v) Propane C<sub>3</sub>H<sub>8</sub> in air and using the relative response data given in the table of this chapter. These values are only valid for new sensors and may vary after aging or poisoning and, unless otherwise stated, they refer to an ambient temperature of 20°C. If using a reference gas to calibrate the gas detector the displayed values may vary by up to +/- 20% from the target gas concentration.

### Reference calibration example for 50% Methanol:

- (1) Relative response factor for Methanol from table = 0.62
- (2) Propane calibration gas concentration being used = 0.89 Vol %  
C<sub>3</sub>H<sub>8</sub>
- (3) Propane volume concentration for 100 % LEL = 1.7 Vol %
- (4) Propane calibration gas concentration in % LEL
- $$= 0.89 \text{ Vol \% C}_3\text{H}_8 \times \frac{100 \text{ \% LEL}}{1.7 \text{ Vol \% C}_3\text{H}_8} = 52.4 \text{ \% LEL}$$
- (5) Gas detector span setting = 52.4 % LEL x 0.62 = 32.5 % LEL

Gas	CAS-No.	LEL [vol%]	Response time [s] [t50] <sup>*)</sup>	Response time [s] [t90] <sup>*)</sup>	Gas/Fluid	Response factor
Acetone (C <sub>3</sub> H <sub>6</sub> O)	67-64-1	2.5	≤ 10	≤ 27	fluid	0.97 <sup>D</sup>
2-Butanone [C <sub>4</sub> H <sub>8</sub> O]	78-93-3	1.5	≤ 13	≤ 59	fluid	1.37 <sup>D</sup>
Ethanol [C <sub>2</sub> H <sub>6</sub> O]	64-17-5	3.1	≤ 10	≤ 42	fluid	0.97 <sup>D</sup>
1-Ethoxy-2 propanol [C <sub>5</sub> H <sub>12</sub> O <sub>2</sub> ]	1569-02-4	1.3	≤ 24	≤ 85	fluid	1.63 <sup>D</sup>
Ethyl acetate [C <sub>4</sub> H <sub>8</sub> O <sub>2</sub> ]	141-78-6	2.0	≤ 15	≤ 39	fluid	1.23 <sup>D</sup>
FAM Benzine 65/95	64742-49-0	0.7	≤ 10	≤ 18	fluid	2.06 <sup>D</sup>
Hydrogen [H <sub>2</sub> ]	1333-74-0	4.0	≤ 7	≤ 13	gas	0.50 <sup>D</sup>
Methane [CH <sub>4</sub> ]	74-82-8	4.4	≤ 8	≤ 14	gas	0.55 <sup>M</sup>
Propane [C <sub>3</sub> H <sub>8</sub> ]	74-98-6	1.7	≤ 8	≤ 15	gas	1.00 <sup>D</sup>
1-Propanol [C <sub>3</sub> H <sub>8</sub> O]	71-23-8	2.1	≤ 13	≤ 44	fluid	1.44 <sup>D</sup>
2-Propanol [C <sub>3</sub> H <sub>8</sub> O]	67-63-0	2.0	≤ 12	≤ 29	fluid	1.12 <sup>D</sup>
Propene [C <sub>3</sub> H <sub>6</sub> ]	115-07-1	2.0	≤ 9	≤ 17	gas	0.81 <sup>D</sup>
Toluene [C <sub>7</sub> H <sub>8</sub> ]	108-88-3	1.0	≤ 15	≤ 41	fluid	1.36 <sup>D</sup>
n-Nonane [C <sub>9</sub> H <sub>20</sub> ]	111-84-2	0.7	≤ 14	≤ 33	fluid	1.92 <sup>D</sup>

All response factors relate to propane

<sup>\*)</sup> Response times are with a flow through adapter and a gas flow of 1 l/min



<sup>D</sup> Response factor defined by DEKRA Testing and Certification GmbH

<sup>M</sup> Response factor defined by MSA (not included in the EU-Type Examination Certificate BVS 10 ATEX E 009 X)

## 7 Approvals

### 7.1 Marking, Certificates and Approvals according to the Directive 2014/34/EU (ATEX) and National Standards

#### PrimaX P

Manufacturer:	MSA Europe GmbH Schlüsselstr. 12 CH - 8645 Rapperswil-Jona	
Product:	<b>PrimaX P</b>	
EU-Type Examination Certificate:	BVS 10 ATEX E009 X by DEKRA Testing and Certification GmbH (NB 0158)	
Standards:	EN 60079-1:2014, EN 60079-0:2018, EN 60079-11:2012, IEC 60079-31:2022	
Performance:	EN 60079-29-1:2016 +A1:2022 + A11:2022, EN 50271:2018, EN 50104:2019 + A1:2023	
Gases:	Measure range: 0-100 % LEL Methane, Propane, 2-Butanone, Acetone, Ethanol, Ethyl acetate, FAM-Benzene 65/95, 2-Propanol, Propene, Toluene, Hydrogen, 1-Ethoxy-2-Propanole, 1-Propanol, n-Nonane	
Type Examination Certificate:	PFG 11 G 001 by DEKRA Testing and Certification GmbH Oxygen: 0-10 % (V/V), 0-25 % (V/V)  EN 45544 -1:1999; EN 45544 -2:1999 Tox: H <sub>2</sub> S: 0-20 ppm; 0-100 ppm; CO: 0-100 ppm; 0-1000 ppm	
Marking:	Prima X P	U <sub>m</sub> = 60 VDC
	Main housing	
		II 2G Ex db ia (ia) IIC T4/T6 Gb II 2D Ex tb ia (ia) IIIC T130°C / T85°C Db IP 67 T4 -40°C ≤ Ta ≤ +70°C, T6 -40°C ≤ Ta ≤ +40°C T130°C -40°C ≤ Ta ≤ +70°C, T85°C -40°C ≤ Ta ≤ +40°C
	Prima X Combustible sensor	
		Ex db IIC T4/T6 Gb Ex tb IIIC T130°C / T85°C Db IP 67 T4 -40°C ≤ Ta ≤ +70°C, T6 -40°C ≤ Ta ≤ +40°C T130°C -40°C ≤ Ta ≤ +70°C, T85°C -40°C ≤ Ta ≤ +40°C
	Prima X Ox/Tox sensor	
		Ex ia IIC T4 Gb Ex ia IIIC T135°C Db IP 67 -40°C ≤ Ta ≤ +70°C
Option:	HART Module Connector, only for temporary connection of an intrinsic safe HART Field Communicator  P <sub>o</sub> ≤ 185 mW, U <sub>o</sub> ≤ 2,7 V, I <sub>o</sub> ≤ 137 mA, L <sub>o</sub> ≤ 10 μH, C <sub>o</sub> ≤ 1 nF  P <sub>i</sub> ≤ 5 mW, U <sub>i</sub> ≤ 5 V, I <sub>i</sub> ≤ 1 mA, L <sub>i</sub> = 0, C <sub>i</sub> = 0  Relay: switching voltage = 30 VDC; switching current = 2 ADC	

#### Special Conditions for Safe Use

- Do not open the instrument when energised.
- Intensive electrostatic charging processes have to be prevented on the instrument label.

- The joint widths of the flameproof joint of this apparatus are in parts longer, and its gaps are in parts shorter than the values of Table 2 of EN 60079-1:2014. For maintenance or repair contact the manufacturer.

In case of using the **PrimaX Ex-Sensor**, the complete device type **PrimaX P** is in accordance to temperature class T6/T85°C, ambient temperature range  $-40^{\circ}\text{C} \leq T_a \leq +40^{\circ}\text{C}$  or to temperature class T4/T130°C, ambient temperature range  $-40^{\circ}\text{C} \leq T_a \leq +70^{\circ}\text{C}$

In case of using the **PrimaX Ox-Tox-Sensor**, the complete device type **PrimaX P** is in accordance to temperature class T4/T130°C, ambient temperature range  $-40^{\circ}\text{C} \leq T_a \leq +70^{\circ}\text{C}$

Avoid electrostatic charge on the temporary used calibration cap when used for calibration.

Cable gland

- M25 x 1,5; Torque 8 -12 Nm; only ATEX certified versions for gas and dust shall be used.
- NPT ¾"- 14; fixture with 2 layer PTFE sealing tape or according to the instructions of the NPT supplier; when removed, new PTFE sealing has to be used after reinstalling; only ATEX certified versions for gas and dust shall be used.

The HART-interface is subject of this type examination certificate only for the purpose of maintenance and parametrization.

When the HART-/ relay module is used the alarm shall be configured latching.

If a device with a combustible sensor is exposed to vibrations, calibration shall be done in sufficient short intervals until it is verified that the device is not affected by the vibration stress.

After exposure of gas above the measuring range, the sensor has to be immediately calibrated/adjusted, independent of the calibration interval. In the case of an adjustment the sensitivity of the sensor has to be rechecked again after 24 hours.

Quality Assurance Notification: see Label

Year of Manufacture: see Label

Serial Nr.: see Label

Accessories included in the type examination:

- Remote calibration adapter CalGard, part.-no. 10150921
- Sensor Gard, part.-no. 10113033
- Flow through adapter, part.-no. 10113031
- Calibration cap, part.-no. 10112789

### PrimaX I

Manufacturer:	MSA Europe GmbH Schlüsselstrasse 12 CH-8645 Rapperswil-Jona
Product:	<b>PrimaX I</b>
EU-Type Examination Certificate:	BVS 10 ATEX E009 X by DEKRA Testing and Certification GmbH (NB 0158)
Standards:	EN 60079-11:2012, EN 60079-0:2018
Performance:	EN 50104:2019 + A1:2023, EN 50271:2018
Type Examination Certificate:	PFG 11 G 001 by DEKRA Testing and Certification GmbH Oxygen: 0-10 % (V/V), 0-25 % (V/V)  EN 45544 -1:1999; EN 45544 -2:1999 Tox: H2S: 0-20 ppm; 0-100 ppm; CO: 0-100 ppm; 0-1000 ppm
Marking:	Prima X I  II 1G Ex ia IIC T4 Ga -40°C ≤ Ta ≤ +70°C  $P_i \leq 700 \text{ mW}$ , $U_i \leq 28 \text{ V}$ , $I_i \leq 100 \text{ mA}$ , $L_i = 0$ , $C_i = 0$
Option:	HART Module Connector, only for temporary connection of an intrinsic safe HART Field Communicator  $P_o \leq 700 \text{ mW}$ , $U_o \leq 28 \text{ V}$ , $I_o \leq 100 \text{ mA}$ , $L_o \leq 10 \mu\text{H}$ , $C_o \leq 1 \text{ nF}$ $P_i \leq 5 \text{ mW}$ , $U_i \leq 5 \text{ V}$ , $I_i \leq 1 \text{ mA}$ , $L_i = 0$ , $C_i = 0$

#### Special conditions for safe use:

It is not allowed to open the key pad cover during usage in areas where EPL Ga, Group IIC is required.

Avoid electrostatic charge on the temporary used calibration cap when used for calibration.

Quality Assurance Notification: see Label

Year of Manufacture: see Label

Serial Nr.: see Label

#### Accessories included in the type examination:

- Remote calibration adapter CalGard, part.-no. 10150921
- Sensor Gard, part.-no. 10113033
- Flow through adapter, part.-no. 10113031
- Calibration cap, part.-no. 10112789

## 7.2 Marking and Certificates according to IECEx

### PrimaX P

Manufacturer:	MSA Europe GmbH Schlüsselstrasse 12 CH-8645 Rapperswil-Jona	
Product:	<b>PrimaX P</b>	
IEC-Type Examination Certificate:	IECEx BVS 10.0043 X	
Standards:	IEC 60079-0:2017, IEC 60079-1:2014, IEC 60079-11:2011, IEC 60079-31:2022	
Performance:	none	
Gas:	see manual	
Marking:	Prima X P	
	Main housing	$U_m = 60 \text{ VDC}$
	Ex db ia (ia) IIC T4/T6 Gb Ex tb ia (ia) IIIC T130°C / T85°C Db IP 67 T4 -40°C ≤ Ta ≤ +70°C, T6 -40°C ≤ Ta ≤ +40°C T130°C -40°C ≤ Ta ≤ +70°C, T85°C -40°C ≤ Ta ≤ +40°C	
	Prima X Combustible sensor	
	Ex db IIC T4/T6 Gb Ex tb IIIC T130°C / T85°C Db IP 67 T4 -40°C ≤ Ta ≤ +70°C, T6 -40°C ≤ Ta ≤ +40°C T130°C -40°C ≤ Ta ≤ +70°C, T85°C -40°C ≤ Ta ≤ +40°C	
	Prima X Ox/Tox sensor	
	Ex d ia IIC T4 Ga Ex ia IIIC T130°C Db IP 67 -40°C ≤ Ta ≤ +70°C	
Option:	HART Module Connector, only for temporary connection of an intrinsic safe HART Field Communicator $P_o \leq 185 \text{ mW}$ , $U_o \leq 2,7 \text{ V}$ , $I_o \leq 137 \text{ mA}$ , $L_o \leq 10 \text{ } \mu\text{H}$ , $C_o \leq 1 \text{ nF}$ , $P_i \leq 5 \text{ mW}$ , $U_i \leq 5 \text{ V}$ , $I_i \leq 1 \text{ mA}$ , $L_i = 0$ , $C_i = 0$ Relays: switching voltage: 30 VDC; switching current: 2 ADC	

#### Special conditions for safe use:

- Do not open the instrument when energised.
- Intensive electrostatic charging processes on the instrument label have to be prevented on the instrument label.
- The joint widths of the flameproof joint of this apparatus are in parts longer, and its gaps are in parts shorter than the values of Table 2 of EN 60079-1:2014. For maintenance or repair contact the manufacturer.

In case of using the **PrimaX Ex-Sensor**, the complete device type **PrimaX P** is in accordance to temperature class T6/T85°C, ambient temperature range -40°C ≤ Ta ≤ +40°C or to temperature class T4/T130°C, ambient temperature range -40°C ≤ Ta ≤ +70°C

In case of using the **PrimaX Ox-Tox-Sensor**, the complete device type **PrimaX P** is in accordance to temperature class T4/T130°C, ambient temperature range -40°C ≤ Ta ≤ +70°C

Avoid electrostatic charge on the temporary used calibration cap when used for calibration.

Cable gland: M25 x 1,5; Torque 8 -12 Nm; only ATEX certified versions for gas and dust shall be used.

NPT ¾"- 14; fixture with 2 layer PTFE sealing tape or according to the instructions of the NPT supplier; when removed, new PTFE sealing has to be used after reinstalling; only ATEX certified versions for gas and dust shall be used.

Quality Assurance Notification: see Label

Year of Manufacture: see Label

Serial Nr.: see Label

### PrimaX I

Manufacturer: MSA Europe GmbH  
Schlüsselstrasse 12  
CH-8645 Rapperswil-Jona

Product: **PrimaX I**

IEC-Type Examination Certificate: IECEx BVS 10. 0043 X

Standards: IEC 60079-0:2017, IEC 60079-11:2011

Performance: none

Gas: see manual

Marking: Prima X I

Ex ia IIC T4 Ga  
-40°C ≤ Ta ≤ +70°C

$P_i \leq 700 \text{ mW}$ ,  $U_i \leq 28 \text{ V}$ ,  $I_i \leq 100 \text{ mA}$ ,  $L_i = 0$ ,  $C_i = 0$

Option: HART Module Connector, only for temporary connection of an intrinsic safe HART Field Communicator

$P_o \leq 700 \text{ mW}$ ,  $U_o \leq 28 \text{ V}$ ,  $I_o \leq 100 \text{ mA}$ ,  $L_o \leq 10 \text{ }\mu\text{H}$ ,  $C_o \leq 1 \text{ nF}$   
 $P_i \leq 5 \text{ mW}$ ,  $U_i \leq 5 \text{ V}$ ,  $I_i \leq 1 \text{ mA}$ ,  $L_i = 0$ ,  $C_i = 0$

### Special conditions for safe use:

- It is not allowed to open the key pad cover by use in areas where Category 1G, Group IIC is required.
- Avoid electrostatic charge on the temporary used calibration cap when used for calibration.

Quality Assurance Notification: see Label

Year of Manufacture: see Label

Serial Nr.: see Label

## 7.3 Special conditions for the safe use according to ATEX, EN 50104, and SIL applications

### Safety relevant parameters for the Gas Transmitters

Type	B
Structure	1oo1 or 1oo2
HFT	0 or 1
PFD, PFH, SFF	see table
$\lambda_{tot}$ , $\lambda_D$ , $\lambda_{DU}$ , $\lambda_{DD}$	see table
MTTR	72 h
T1	16 weeks [Proof-Test-Interval]

### Possible structures and acquirable SILs

The following table shows, which structure has to be selected, to fulfill the requirements of a special SIL.

LDM = Low Demand Mode

HDM = High Demand or Continuous Mode

	SIL1		SIL2		SIL3	
	LDM	HDM	LDM	HDM	LDM	HDM
<b>Structure 1oo1</b>	X	X	X			
<b>Structure 1oo2</b>	X	X	X	X	X	X

Depending on the selected configuration and the sensor version, the following safety-relevant parameters have to be considered while implementing the safety loop:

#### General conditions for the safe use

- The application advice and the limitations of the manual have to be considered. For calibration and maintenance, the regional and national regulations have to be considered.
- For PrimaX I, no indicators are provided on the equipment to show that the equipment is energised or in a special state. Therefore, the indicators have to be shown on the gas detection control unit.
- A defect transmitter has to be repaired within 72 hours.
- The HART® interface is not allowed to be used for the transmission of safety related data.
- The alarm conditions of the transmitter must be periodically checked together with the typical gas calibration checks.
- The relays must be energised under normal conditions.
- The relay contacts must be protected with a fuse rated 0.6 of the nominal specified relay contact current.
- The failure relay contacts must be safety related processed for warning purposes when the 4 to 20 mA link is not use for the alarm condition.
- The tests of the 4-20 mA - output signal and alarm conditions and the test of the alarm and fault relays, LEDs and display have to be done during calibration.
- The connected controller has to monitor the 4-20 mA signal current for values below 4 mA and above 20 mA.
- For the correct use of the combustible sensor a minimum oxygen concentration of 10 Vol% is necessary.
- The presence of catalytic poisons has to be avoided for the combustible sensor.
- A functional check/calibration check has to be done for the complete system.
- A visual check has to be done monthly.
- A system operation check has to be done every year.
- Calibration is only signaled on the 4-20 mA output by the service current. Therefore, the 4-20 mA output shall be monitored at automatic calibration, if the sum of the application times parametrized for zero gas and span gas application and the idle time exceeds 15 minutes, and at manual calibration.
- For the test gas, the gas has to be used which is defined for the measurement. The concentration of the test gas has to be in the middle of the measure range.
- For zero gas, synthetic air has to be used.
- An adjustment has to be done under the following conditions:  
difference at zero > +/- 5 % UEG  
difference at sensitivity > +/- 20 % of the rated value
- If the calibration is inside of the valid tolerance, the calibration interval can be doubled.
- The maximum of the calibration interval is 16 weeks.
- The sensor has to be replaced if the sensor sensitivity during the operation is reduced to less than 50 % of the initial sensitivity.
- After exposure of gas above the measuring range, the sensor has to be immediately calibrated/adjusted, independent of the calibration interval. In the case of an adjustment the sensitivity of the sensor has to be rechecked again after 24 hours.
- If the appearance of catalytic poisons for the combustible sensor can not be avoided, the calibration interval has to be considerably reduced.

#### Special conditions for SIL 2

- The use of the sensors in a High Demand or Continuous Mode is allowed only in a 1002 - structure.
- The outputs of the sensors [4-20 mA - loops and relay contacts] must to be monitored regarding deviations.

**Special conditions for SIL 3**

- The use of the sensors is allowed only in a 1oo2 - structure.
- The outputs of the sensors [4-20 mA - loops and relay contacts] must to be monitored regarding deviations.

**7.4 Safety Relevant Parameters [40°C]****Application with Relay**

	$\lambda_{total}$	$\lambda_S$	$\lambda_D$	$\lambda_{DU}$	$\lambda_{DD}$	SFF	DC	PFD <sub>1oo1</sub>	PFD <sub>1oo1</sub>	PFD <sub>1oo2</sub>	PFD <sub>1oo2</sub>	PFD <sub>1oo2</sub>	PFD <sub>1oo2</sub>	PFD <sub>1oo2</sub>	
	fit	fit	fit	fit	fit	%	%		% of SIL 2		% of SIL 3	1/h	% of SIL 1	1/h	% of SIL 3
Ammonia [NH <sub>3</sub> ]	3737	2469	1269	415	854	88.9	67.3	7.9E-04	5.6	1.2E-05	1.2	4.2E-07	4.2	8.7E-09	8.7
Carbon Monoxide [CO]	3187	2194	994	255	739	92.0	74.4	3.4E-04	3.4	7.0E-06	0.7	2.5E-07	2.5	5.3E-09	5.3
Chlorine [Cl <sub>2</sub> ]	4332	2766	1566	589	978	86.4	62.4	7.8E-04	7.9	1.7E-05	1.7	5.9E-07	5.9	1.3E-08	12.7
Combustible	6666	3933	2733	1066	1667	84.0	61.0	1.4E-03	14.3	3.1E-05	3.1	1.1E-06	10.7	2.4E-08	24.2
Hydrogen [H <sub>2</sub> ]	3737	2469	1269	415	854	88.9	67.3	7.8E-04	5.6	1.2E-05	1.2	4.2E-07	4.2	8.7E-09	8.7
Hydrogen Chloride [HCl]	4297	2749	1549	578	970	86.5	62.7	1.0E-04	7.8	1.6E-05	1.6	5.8E-07	5.8	1.2E-08	12.4
Hydrogen Cyanide [HCN]	3995	2598	1398	490	907	87.7	64.9	7.5E-04	6.6	1.4E-05	1.6	5.6E-07	5.6	1.2E-08	12.0
Hydrogen Sulphide [H <sub>2</sub> S]	3187	2194	994	255	739	92.0	74.4	5.6E-04	3.4	7.0E-06	0.7	2.5E-07	2.5	5.3E-09	5.3
Nitrogen Dioxide [NO <sub>2</sub> ]	4237	2718	1518	561	958	86.8	63.1	7.5E-04	7.5	1.6E-05	1.6	5.6E-07	5.6	1.2E-08	12.0
Nitrogen Oxide [NO]	4877	3039	1839	748	1091	84.7	59.3	1.0E-03	10.0	2.1E-05	2.1	7.5E-07	7.5	1.6E-08	16.4
Oxygen [O <sub>2</sub> ]	6044	3622	2422	655	1767	89.2	73.0	8.8E-04	8.8	1.9E-05	1.9	6.5E-07	6.5	1.4E-08	14.2
Sulphur Dioxide [SO <sub>2</sub> ]	4297	2749	1549	578	970	86.5	62.7	5.6E-04	7.8	1.6E-05	1.6	5.8E-07	5.8	1.2E-08	12.4

**7.4.1 Application with 4-20 mA Current Output**

	$\lambda_{total}$	$\lambda_S$	$\lambda_D$	$\lambda_{DU}$	$\lambda_{DD}$	SFF	DC	PFD <sub>1k</sub>	PFD <sub>1oo1</sub>	PFD <sub>1oo2</sub>	PFD <sub>1oo2</sub>	PFD <sub>1oo2</sub>	PFD <sub>1oo2</sub>	PFD <sub>1oo2</sub>	PFD <sub>1oo2</sub>
	fit	fit	fit	fit	fit	%	%		% of SIL 2		% of SIL 3	1/h	% of SIL 1	1/h	% of SIL 3
Ammonia [NH <sub>3</sub> ]	1734	867	867	363	504	79.1	58.1	4.9E-04	4.9	1.0E-05	1.0	3.6E-07	3.6	7.6E-09	7.6
Carbon Monoxide	1183	592	592	202	389	82.9	65.8	2.7E-04	2.7	5.5E-06	0.6	2.0E-07	2.0	4.2E-09	4.2

	$\lambda_{total}$	$\lambda_S$	$\lambda_D$	$\lambda_{DU}$	$\lambda_{DD}$	SFF	DC	PFD 1k	PFD 1001	PFD 1002	PFD 1002	PFD 1002	PFD 1002	PFD 1002	PFD 1002
	fit	fit	fit	fit	fit	%	%		% of SIL 2		% of SIL 3	1/h	% of SIL 1	1/h	% of SIL 3
[CO]															
Chlorine [Cl <sub>2</sub> ]	2328	1164	1164	536	628	77.0	53.9	7.2E-04	7.2	1.5E-05	1.5	5.4E-07	5.4	1.1E-08	11.5
Combustible	4662	2331	2331	1013	1318	78.3	56.5	1.4E-03	13.6	3.0E-05	3.0	1.0E-06	10.1	2.3E-08	22.9
Hydrogen [H <sub>2</sub> ]	1734	1437	1437	363	504	79.1	58.1	4.9E-04	4.9	1.0E-05	1.0	3.6E-07	3.6	7.6E-09	7.6
Hydrogen Chloride [HCl]	2294	1117	1117	526	621	77.1	54.1	7.1E-04	7.1	1.5E-05	1.5	5.3E-07	5.3	1.1E-08	11.2
Hydrogen Cyanide [HCN]	1992	867	867	438	558	78.0	56.0	5.9E-04	5.9	1.2E-05	1.2	4.4E-07	4.4	9.3E-09	9.3
Hydrogen Sulphide [H <sub>2</sub> S]	1183	592	592	202	389	82.9	65.8	2.7E-04	2.7	5.5E-06	0.6	2.0E-07	2.0	4.2E-09	4.2
Nitrogen Dioxide [NO <sub>2</sub> ]	2233	1147	1147	509	608	77.2	54.5	6.8E-04	6.8	1.4E-05	1.4	5.1E-07	5.1	1.1E-08	10.8
Nitrogen Oxide [NO]	2874	1437	1437	695	741	75.8	51.6	9.3E-03	9.3	2.0E-05	2.0	7.0E-07	7.0	1.5E-08	15.2
Oxygen [O <sub>2</sub> ]	4040	2020	2020	602	1418	85.1	70.2	8.1E-04	8.1	1.7E-05	1.7	6.0E-07	6.0	1.3E-08	13.0
Sulphur Dioxide [SO <sub>2</sub> ]	2294	1147	1147	526	621	77.1	54.1	7.1E-04	7.1	1.5E-05	1.5	5.3E-07	5.3	1.1E-08	11.2

## 8 Accessories

For part numbers → chapter 10 Spare Parts.

### 8.1 Calibration Cap

Using calibration cap allows span gas calibration procedure to be accurate in windy environmental conditions.

The calibration cap is pushed on to the front of the sensor and is sealed by an O-ring. The surface area  $S < 20 \text{ cm}^2$ .



Figure 13 Calibration cap / Gas flow rate:  $1.0 \text{ l/min} \pm 20\%$



#### WARNING!

The calibrating cap must be removed after completing the calibration!

The gas is supplied via either of the gas inlets by means of suitable flexible tube.

**Failure to follow this warning can result in serious personal injury or death.**

### 8.2 Sensor Gard



Figure 14 Sensor gard / Gas flow rate:  $1.0 \text{ l/min} \pm 20\%$

The sensor gard should be fitted at all times except when using the flow through adapter, duct mount kit or CalGard.

Ambient weather condition can affect the gas mixture inside of the sensor gard. Use sensor gard for functional test only. Calibration cap is recommended for sensor calibration.



Using the sensor gard will extend the response time, depending on the air velocity. Very low air velocity may result in reduced measure value slightly above 10%.

Gas flow rate:  $1,0 \text{ l/min}$

## 8.3 Remote Calibration



Figure 15 PrimaX with CalGard

The CalGard stainless steel remote calibration adaptor provides reliable operation of remotely installed gas detectors working under harsh environmental conditions. Additionally, the CalGard allows remote verification ("bump test") or instrument calibration of gases listed later in this section and oxygen via a hose connection in the presence of wind speeds up to 6 m/s.

In normal measurement operation, the ambient air passes through the air vents into the remote calibrator directly to the sensor (diffusion operation). During a bump test or instrument calibration, the test gas is supplied to the sensor via the hose connection at the bottom of the CalGard. An integrated mechanism prevents the dilution and dispersion of test gas otherwise caused by external influences, such as wind. This allows a fast response from the sensor to the applied test gas.

Once calibration is complete, the air inlet reopens to allow the monitoring of ambient air for gas without the need for further user intervention.

### 8.3.1 Installation

For correct operation, PrimaX and CalGard must be used in a vertical position (hose connection pointing downwards). The CalGard remote calibration adaptor can be attached to the sensor by screwing on the thread of the detector.



The tube connector is adapted for tubes with an inner diameter of 5 mm.

In general the hose should be as short as possible in order to:

- Minimise the gas volume needed to flush the tube
- Reduce external influences (e.g. temperature shift, pressure, etc.)
- Minimise the lead time

Hose material should be adapted to the applied test gas, have no absorptive or adsorptive properties and should be made from inert material such as teflon or polyethylene.

When using the CalGard in the hazardous area, a conductive hose must be used.

The free end of the test gas tube must be closed if no test gas is applied. This is to prevent gas or air passing through the tube to the sensor, distorting the measurement or in the reverse pressure conditions, the ambient atmosphere escapes from the sensor at the free end of the tube.

To ensure proper function the CalGard remote calibration adaptor must be kept dry and free of any contaminants, e.g. dust particles. Regular visual checks are recommended. Any contaminants must be removed by blowing them off with clean, oil-free compressed air or with a dry brush. Ensure that the air entrances are kept free from any coating, e.g. paint, grease or similar.

### 8.3.2 Operation

Calibration procedure can be carried out as described in chapter [4.3 Calibration](#) of this manual.

To compensate for possible deviations during measurement of flammable gases a calibration factor of 1.05 has to be applied.

Example: Calibration for methane.

Apply 40 %LEL methane and adjust to  $1.05 \times 40 = 42$  %LEL

When using the CalGard for a remote calibration, the response time of the system increases depending on the length of the test gas tubes used. If the calibration is done automatically, set the calibration setup (menu: M04) with sufficiently long countdown times for zero gas and calibration gas.

Example: When using a 10 metre long tube with an internal diameter of 5 mm and applying a gas flow of 1 litre/min, the test gas takes a minimum of 20 sec to reach the CalGard remote calibration adaptor. For safe flushing of CalGard, an additional 10 seconds has to be added to this calculation.

If the CalGard is being used with a control system (i.e. SUPREMA), please ensure the manual for the controller has been read and understood.

The pressure in the test gas tube increases with rising test gas flow rates. A flow rate of 1500 ml/min results in a pressure up to 600 hPa. This has to be considered if a flow meter is used which is affected by the media pressure.

<b>Material</b>	St. St. 316	
<b>Dimensions (in mm)</b>	60 x 122 (diameter x height)	
<b>Weight</b>	0.6 kg	
<b>Working temperature</b>	-30 °C to +70 °C	
<b>Storage temperature</b>	-30 °C to +70 °C	
<b>Max. wind speed</b>	up to 6 m/s	
<b>Applicable test gases</b>	H <sub>2</sub> , CH <sub>4</sub> , C <sub>3</sub> H <sub>8</sub> , CO and H <sub>2</sub> S in air, O <sub>2</sub> in N <sub>2</sub> (approval of other gases by MSA on request)	
Recommended flow rate	1.0 l / min	
Minimum flow rate	0,8 l / min	
Maximum flow rate	1.5 l / min	
<b>Response times</b>		
CH <sub>4</sub>	t <sub>50</sub> ≤ 15 s	t <sub>90</sub> ≤ 40 s
C <sub>3</sub> H <sub>8</sub>	t <sub>50</sub> ≤ 20 s	t <sub>90</sub> ≤ 55 s
O <sub>2</sub>	t <sub>50</sub> ≤ 10 s	t <sub>90</sub> ≤ 45 s
	CO t <sub>50</sub> ≤ 15 s	t <sub>90</sub> ≤ 45 s
H <sub>2</sub> S	t <sub>50</sub> ≤ 20 s	t <sub>90</sub> ≤ 60 s

## 8.4 Flow Through Adapter



Figure 16 Flow through adapter

The symmetric flow through adapter is for use with a pumped sampling system. The gas is supplied via either of the gas inlets by means of suitable flexible tube or pipe. The material should be adapted to the applied test gas, have no absorptive or adsorptive properties and should be made from inert material such as teflon or polyethylene.

Hose Inner diameter of 5 mm is recommended. The length of the hose should not exceed 30 m.

Gas inlet/outlet thread:	1/8" NPT
Gas flow rate:	1.0 l/min $\pm$ 20%



Using the Flow Through Adapter will extend the response time, depending on the gas flow rate and the length of the tubes. Only the pressure range from 800 to 1200 hPa is allowed. The gas flow has to be monitored.

## 8.5 Duct Mounting Kit



*Figure 17 Duct mounting kit*

Gas monitoring in air ducts can be performed by means of this duct mounting kit. When installing, the direction of flow inside the duct must be towards the baffles.

The sensor can be calibrated via the gas calibration port, provided the duct is free of all gases to which the sensor will respond. If the duct cannot be gas free, the sensor must be removed from the duct during calibration.

The calibration port must be sealed again with the locking cap after calibration has been carried out.

Calibration should only be carried out with the calibration port if the air velocity is  $< 5$  m/s in the air duct.



The performance of the duct mounting kit depends on various parameters and has to be checked before usage. The kit was not part of the EU Type Examination.

## 8.6 Pipe Mounting Kit

The PrimaX can be mounted vertically by fastening its back plane using two screws and washers. Additionally, a pipe mount kit allowing the PrimaX to be fixed to pipes or poles is available as an accessory.

The kit consists of:

- one universal mounting plate
- one retaining plate for pipes with a diameter of 20 – 30 mm
- one retaining plate for pipes with a diameter of 30 – 50 mm
- two tightening straps for pipes with a diameter of 50 – 150 mm.



Figure 18 Mounting plate



Figure 19 Retaining plate



Figure 20 Tightening straps

NOTE: The Pipe mounting kit not included in the EC-Type Examination Certificate BVS 10 ATEX E 009 X

### 8.7 Sensor Tag



Figure 21 Sensor tag

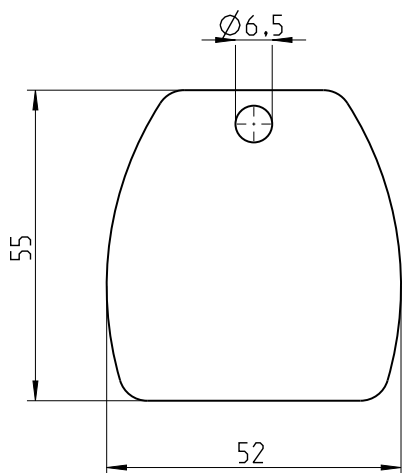

Figure 22 Measurements sensor tag

The stainless steel label allows to identify and tag the location or installation of the instrument on the site.

## 8.8 Sunshield



Figure 23 Sunshield

Stainless steel plate to protect the transmitter from direct sunlight.

## 8.9 Universal HART Cable



*Figure 24 Universal HART cable*

Universal cable that will connect the PrimaX detector to any standard HART handheld [f.e. Emerson 375] using the HART connector.

## 9 Disposal

For disposal of the device local regulations are to be observed.

## 10 Spare Parts

### List of Accessories\*

Description	Material	Part Number
Sensor Gard	Plastic	10113033
Flow Through Adapter	St.St. 316	10113031
Duct Mounting Kit	St.St. 316	10112790
Pipe Mounting Kit	St.St. 316	10113032
Sensor Tag	St.St. 316	10113034
Sunshield	St.St. 316	10113035
Calibration Cap	Plastic	10112789
CalGard	St.St. 316	10150921
Universal HART cable [1.5 m]		10113036

### PrimaX I Replacement Parts\*

Description	Part No
Bayonet lock plate & screw	10113042
Sensor bayonet & cap	10113048
Mounting plate	10113041
Lid	10113045
Lid screws [set of 4]	10113046
Keyboard cover	10113040
Cable gland M25 x 1.5, 7 – 17 mm	10113039

### PrimaX P Replacement Parts\*

Description	Part Number
Bayonet lock plate & screw	10113050
Sensor bayonet and cap	10113058
Mounting plate	10113041
Lid	10113056
Keyboard cover	10113040
Cable gland Ex d II CT4 M25 x 1.5	10113038
Cable gland Ex d II CT4 ¾" NPT	10113037

\* For storage details see chapter [6.3 Performance Specifications](#)

## Replacement Sensors\*

Gas	Range (optional)	Part Number
Catalytic Sensor Combustible Gases (Only PrimaX P version)	100% LEL	10112716
Ammonia (NH <sub>3</sub> )	100 ppm (50 ppm)	10080225
Ammonia (NH <sub>3</sub> )	1000 ppm (500 ppm)	10112719
Carbon Monoxide (CO)	200 ppm (100 ppm, 500 ppm, 1000 ppm)	711306
Chlorine (Cl <sub>2</sub> )	10 ppm (5 ppm)	10112720
Hydrogen (H <sub>2</sub> )	1000 ppm	10112723
Hydrogen Chloride (HCl)	30 ppm (10 ppm, 20 ppm)	10112721
Hydrogen Cyanide (HCN)	30 ppm (10 ppm, 20 ppm, 50 ppm)	10188691
Hydrogen Sulphide (H <sub>2</sub> S)	50 ppm (10 ppm, 20 ppm, 100 ppm)	711307
Nitrogen Dioxide (NO <sub>2</sub> )	10 ppm (20 ppm, 100 ppm)	10080224
Nitrogen Oxide (NO)	100 ppm	10112724
Oxygen (O <sub>2</sub> )	0–25% vol. (10 vol%)	10112718
Sulfur Dioxide (SO <sub>2</sub> )	50 ppm (10 ppm, 20 ppm, 100 ppm)	10080223

\* For storage details see chapter [6.3 Performance Specifications](#)



Electrochemical sensors should only be ordered for immediate replacement. The storage temperature should be in the range of +5 °C to +12 °C at 15 % to 90 % rel. humidity. For disposal of electrochemical sensors see chapter [9 Disposal](#).

## 11 Appendix

### 11.1 Output States

Display	Alternating	LED colour*	State	Signal current	Default
		Green	Normal	4 – 20 mA	
		Yellow [flashing]	Startup	Service current	3 mA
		Yellow [flashing]	Calibration	Service current	3 mA
CAL	X	Yellow	Calibration invalid	Service current	3 mA
VCC ↗	X	Yellow	Latched voltage overrange [confirm on device]	Service current	3 mA
LOOP	X	Yellow	Loop not connected [-PrimaX P]		
LO ↘	X	Yellow	Underrange [ $< -10\%$ ]	Error current	2 mA
LO ↘	X	Green	Underrange [ $< -2\%$ ] TOX [ $< -5\%$ ] combustible	3.8 - 4 mA	
HI ↗	X	Green	Overrange [ $> 100\%$ ]	20 – 20.5 mA	
E-XX		Yellow	Error	Error current	2 mA
E-XX		Yellow	Safety critical error	Open loop <ul style="list-style-type: none"> <li>• 0 mA PrimaX P</li> <li>• <math>&lt; 2</math> mA PrimaX I</li> </ul>	

#### Relay versions only

Display	Alternating	LED colour*	State	Signal current
		Red	Alarm	4 - 20 mA
		Red [flashing]	Latched alarm	4 - 20 mA

#### Catalytic sensor only (P/N 10112716)

LOC	X	Red	LOC	20.5 mA
LOC	X	Red	Latched LOC	20.5 mA

LOC: The PrimaX Gas Monitor has been exposed to a high gas concentration [above the LEL], and the over-range condition still exists.

LED Colour\*: PrimaX P only

Latched LOC: The PrimaX Gas Monitor has been exposed to a high gas concentration [above the LEL], and there is a possibility that the over-range condition may still exist.



The output states are displayed alternating to the measuring value [except for ERROR and underrange].

## 11.2 Calibration Errors

Display	Cause	Troubleshooting
FAIL - 1	Zero not stable	Check zero gas and span gas, see settings [M-03] and flow rate, repeat calibration, otherwise replace sensor
FAIL - 2	Zero too low	
FAIL - 3	Zero too high	
FAIL - 4	Span not stable	
FAIL - 5	Span too low	
FAIL - 6	Span too high	
FAIL - 7	Not enough resolution	
FAIL - 8	Catalytic sensor values out of technical specification	

## 11.3 Error Codes

	<p>If an error is detected, the error code E, followed by a numeric code and a short description, will be displayed.</p> <p>In this case the normal operation mode of the device will not respond to gas and the output signal current will be the ERROR value [default 2 mA].</p>
--	--

Display	Cause	Troubleshooting
E-01 – E-19, E-50 – E-53	Latched Hardware/Software Error	E-01 – E-29 latched errors, press any key for reset device
E-20 – E-29	Sensor Cell error	
E-30 – E-39, E-54	Unlatched Hardware/Software Error	E-30 – E-49 non-latched errors, self-deactivating
E-40 – E-47	Relay error	
E-48	Device supply too high	
E-49	Device supply too low PrimaX I (< 11.0 V ± 0.2 V) PrimaX P (< 14.6 V ± 0.2 V)	

If an error code is displayed, the normal operation of the device is not possible.

If the error code is still shown after a reset, the device could be defective.

The removal of the hydrogen cyanide and chlorine sensors will not trigger the E-28 sensor error message.

For additional support please contact MSA Service.

Sensor errors [E-20 – E-29] could be cleared by checking if the sensor is well connected, or by changing the sensor, or also by resetting the device.

The values of [E-49] refers to the device supply voltage at the device terminals. In case of power supply is below the specified range (see chapter [6.1 Specifications](#)) in combination with the cable load resistance (see chapter [6.2 Cable Lengths and Cross-sections](#)) the outputs of the PrimaX I (2-wire transmitter) might be toggling between the error state [E-49] and a faulty signal.

## 11.4 Timeout

The automatic calibration has a timeout of 4 minutes. The manual calibration has a timeout of 60 minutes [M-01, M-02]. Any test procedure [M-06, M-07, M-13 and the sensor exchange M-05] has a timeout of 15 minutes. Anywhere else in the menu the timeout is 2 minutes, if no button is pressed.

## 11.5 Mechanical Installation

### Dimensions

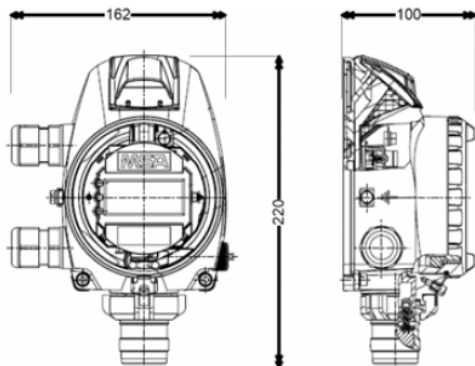

Figure 25 Outline dimensions Prima X P

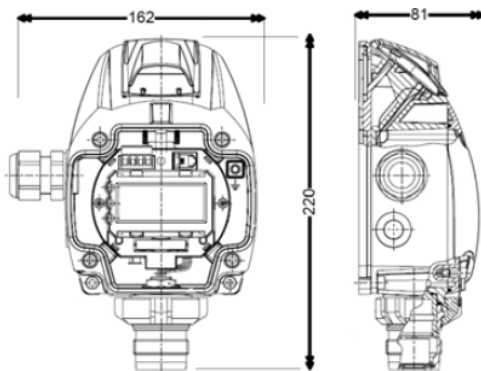

Figure 26 Outline dimensions Prima X I

#### Cable gland

- M25 x 1,5; Torque 8 -12 Nm; only ATEX certified versions for gas and dust shall be used.
- NPT ¾"- 14; fixture with 2 layer PTFE sealing tape or according to the instructions of the NPT supplier; when removed, new PTFE sealing has to be used after reinstalling; only ATEX certified versions for gas and dust shall be used.

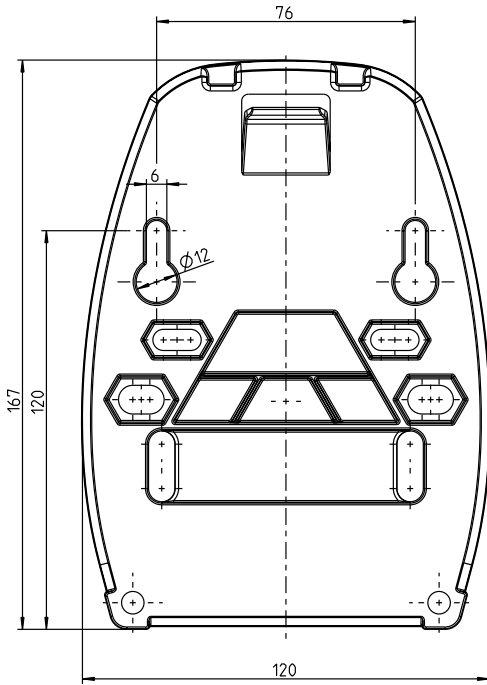

Figure 27 Installation mounting plate

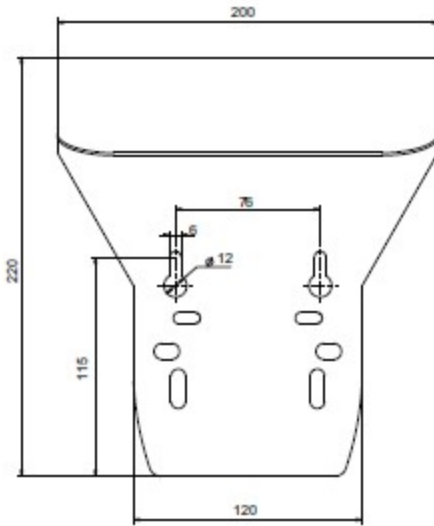

Figure 28 Dimensions sunshield

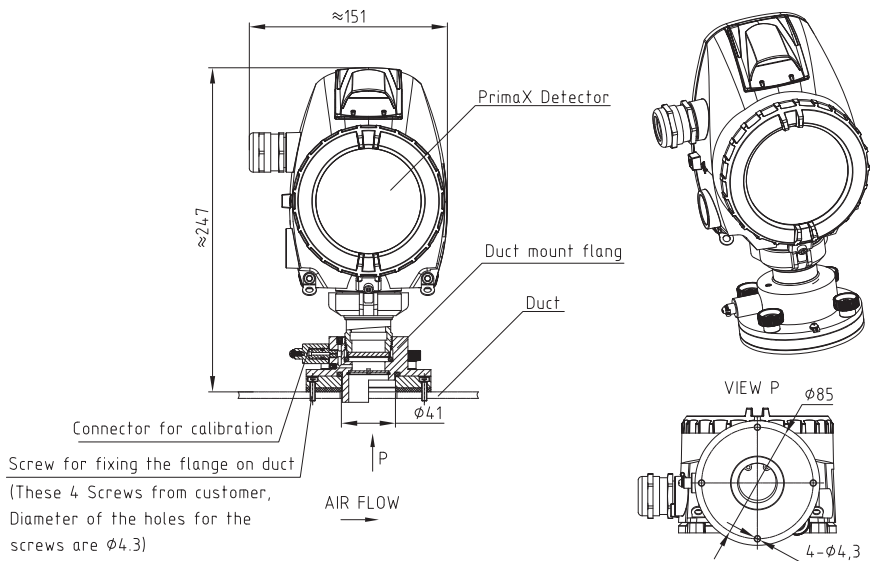

Figure 29 Duct mounting

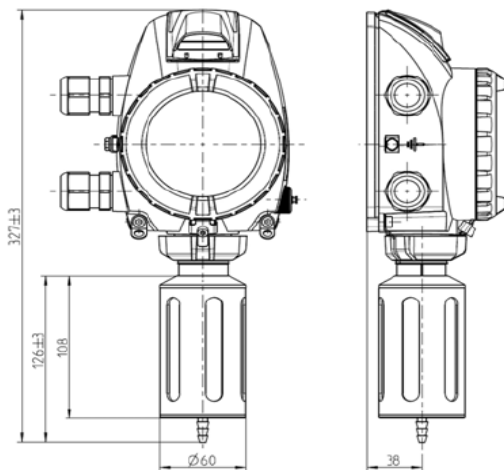
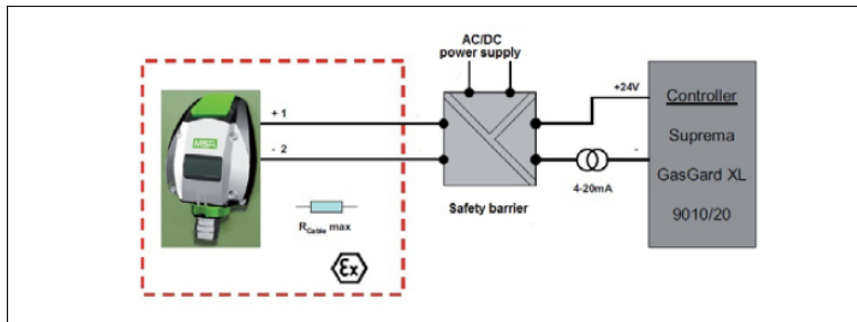
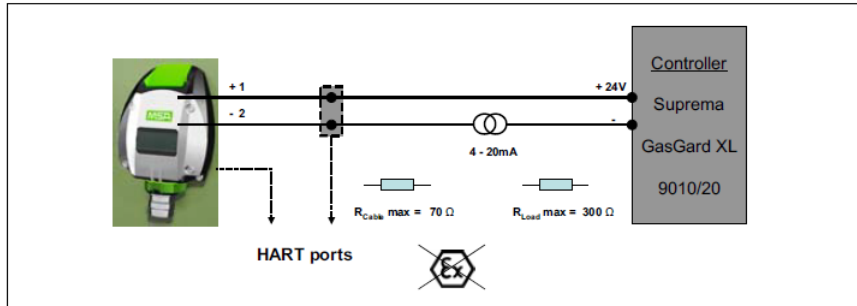
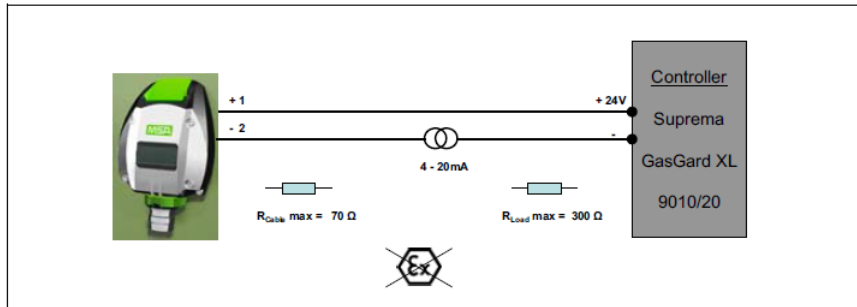

Figure 30 Dimensions CalGard

## 11.6 Wiring Diagrams

The HART communications require a minimum of 250 ohms resistance in the 4 – 20 mA loop.

## PrimaX I, Ex ia, Intrinsically Safe



## PrimaX P, Ex d, Flameproof

