



Operating Manual
PrimaX® IR
Infrared Gas Monitor



Order No.: 10113581/08

Print Spec: 1000005389 (EO)

CR: 80000070581

 **WARNING!**

These instructions must be provided to users before use of the product and retained for ready reference by the user. Read this manual carefully before using or maintaining the device. The device will perform as designed only if it is used and maintained in accordance with the manufacturer's instructions. Otherwise, it could fail to perform as designed, and persons who rely on this device could sustain serious injury or death.

The warranties made by MSA with respect to the product are voided if the product is not installed and used in accordance with the instructions in this manual. Please protect yourself and your employees by following the instructions.

Please read and observe the WARNINGS and CAUTIONS inside. For additional information relative to use or repair, call 1-800-MSA-2222 during regular working hours.

For countries of Russian Federation, Republic of Kazakhstan and Republic of Belarus, the gas detector will be delivered with a passport document that includes valid approval information. On the CD with manual instruction attached to the gas detector the user will find the documents "Type Description" and "Test Method" - appendixes to Pattern Approval Certificate of Measuring instrument, valid in the countries of use.

The Declaration of Conformity can be found under the following link: <https://MSAsafety.com/DoC>.

MSA is a registered trademark of MSA Technology, LLC in the US, Europe and other Countries. For all other trademarks visit <https://us.msasafety.com/Trademarks>.



1000 Cranberry Woods Drive
Cranberry Township, PA 16066
USA
Phone 1-800-MSA-2222

For your local MSA contacts, please go to our website www.MSAsafety.com

Contents

1	Safety Regulations	4
1.1	Correct Use	4
1.2	Liability Information	4
1.3	Safety and Precautionary Measures to be Adopted	5
1.4	MSA Permanent Instrument Warranty	5
2	Description	7
2.1	User Interface	7
2.2	Package Contents	7
3	Installation	10
3.1	Mechanical Installation	10
3.2	Electrical installation	12
4	Start-up and Calibration	15
4.1	Initial Startup	15
4.2	PrimaX IR Calibration	16
4.3	Calibration Kits	23
5	Maintenance	24
5.1	General	24
5.2	Troubleshooting	24
5.3	HART Information for Troubleshooting	25
5.4	Cleaning	25
5.5	Environmental Guard Cleaning	27
5.6	Calibration Cap Cleaning Procedure	27
6	Technical Data	28
7	Accessories	29
7.1	Flow Cap	29
7.2	Sunshield	30
7.3	Duct Mount Kit	30
7.4	HART Module	30
7.5	Insect Guard/Remote Calibration Inserts	31
8	Approvals	33
8.1	PrimaX IR ATEX/IECEX Approval Information	33
8.2	PrimaX IR cFMus Approval Information	34
8.3	Prima X IR Calibration Cap US/CAN/ATEX Marking	35
8.4	Prima X IR Calibration Cap UKCA Marking	36
8.5	Special conditions for the safe use according to ATEX and SIL applications	36

1 Safety Regulations

1.1 Correct Use

The PrimaX IR Gas Monitor - referred to hereafter as device - is a fixed infrared combustible gas detector. It is suitable for outdoor and indoor applications, e.g. offshore industry, chemical and petrochemical industry, water and sewage industry.

The device utilises infrared technology to monitor, detect and alert users to potentially dangerous levels of combustible hydrocarbon gas. Dual source technology offers 100% redundancy on the optical source to maximize reliability and lifetime. This device allows for extremely fast response time whilst providing an extremely stable output signal.

The device is a stand-alone unit with a 4 to 20 mA output with HART [Highway Addressable Remote Transducer] digital information encoded on the analogue output. The signal of the transmitter can be used in combination with MSA control units for further actions in safety or non-safety applications. Contact your MSA representative for available controllers.

The device is shipped factory-calibrated and is labelled with target gas, calibration gas and span setting information for ease of use. Any user changes to the factory assigned values should be noted on the device labels.

The device is explosion-proof and suitable for installation in hazardous locations. This sensor is intended for integration with a control system that can alert operations personnel to the presence of hydrocarbon combustible gas.

It is imperative that this operating manual be read and observed when using the product. In particular, the safety instructions, as well as the information for the use and operation of the product, must be carefully read and observed. Furthermore, the national regulations applicable in the user's country must be taken into account for a safe use. This includes EN/IEC/UL/CSA 60079-29-2.

WARNING!

This product is supporting life and health. Inappropriate use, maintenance or servicing may affect the function of the device and thereby seriously compromise the user's life.

Before use the product operability must be verified. The product must not be used if the function test is unsuccessful, it is damaged, a competent servicing/maintenance has not been made, genuine MSA spare parts have not been used.

For safety reasons this equipment must be operated and serviced by qualified personnel only.

Failure to follow these warnings can result in serious personal injury or death.

Alternative use, or use outside this specification will be considered as non-compliance. This also applies especially to unauthorized alterations to the product and to commissioning work that has not been carried out by MSA or authorized persons.

1.2 Liability Information

MSA accepts no liability in cases where the product has been used inappropriately or not as intended. The selection and use of the product are the exclusive responsibility of the individual operator.

Product liability claims, warranties also as guarantees made by MSA with respect to the product are voided, if it is not used, serviced or maintained in accordance with the instructions in this manual.

1.3 Safety and Precautionary Measures to be Adopted

WARNING!

- The device described in this manual must be installed, operated and maintained in strict accordance with the labels, warnings, cautions, instructions, and within the limitations stated.
- Protect the device from extreme vibration.
- Do not mount the device in direct sunlight without a sunshield, since this may cause it to overheat.
- The only absolute method to ensure proper overall operation of the device is to check it with a known concentration of the gas for which it has been calibrated. Consequently, calibration checks must be included as part of the routine inspection of the system. The device is labeled with the type and value of the factory calibration gas.
- Use only genuine MSA replacement parts when performing any maintenance procedures provided in this manual. Failure to do so may seriously impair device performance. Repair or alteration of the device, beyond the scope of these maintenance instructions or by anyone other than an authorized MSA service provider, could cause the product to fail to perform as designed.
- There are no field-repairable internal components for this device. Return to MSA for warranty replacement per the Warranty section.
- This device does not detect the presence of hydrogen gas and must never be used to monitor for hydrogen gas.
- The standard device must never be used in atmospheres containing acetylene gas. Contact MSA regarding available acetylene sensors.
- Calibrate frequently if used in atmospheres exposed to high levels of solvents or dust. See chapters [4 Start-up and Calibration](#) and [5 Maintenance](#) for calibration and cleaning procedures.
- Do not paint the device. If painting is done in an area where the device is located, exercise caution to ensure paint is not deposited on the device. Such paint deposits could interfere with the device operation. Solvents in the paint may also cause an alarm condition to occur.
- The device is designed for applications in hazardous areas under environmental conditions defined in the Specifications section of this manual.
- The response time of the device can be increased by significant dust deposits. Checks for dust deposits must be done at regular intervals.
- The device's sensor will detect other hydrocarbon gases than the target gas.
- Oxygen enriched atmospheres greater than 21 Vol % can affect the measurement and the electrical safety of the Gas Monitor. Do not use the device in these atmospheres.
- Do not use to detect combustible dusts or mists.

Failure to follow these warnings can result in serious personal injury or death.

1.4 MSA Permanent Instrument Warranty

Warranty

Seller warrants that this product will be free from mechanical defect or faulty workmanship for

- IR Dual source: ten (10) years from date of shipment, as determined by HART communication that both sources are non-functional
- Gas Monitor, excluding accessories: three (3) years from date of shipment
- Calibration cap: one (1) year from date of shipment

This warranty is applicable provided the product is maintained and used in accordance with Seller's instructions and/or recommendations.

The Seller shall be released from all obligations under this warranty in the event repairs or modifications are made by persons other than its own or authorized service personnel or if the warranty claim results from physical abuse or misuse of the product. No agent, employee or representative of the Seller has any authority to bind the Seller to any affirmation, representation or warranty concerning the goods sold under this contract. Seller makes no warranty concerning components or accessories not manufactured by the Seller, but will pass onto the Purchaser all warranties of manufacturers of such components.

THIS WARRANTY IS IN LIEU OF ALL OTHER WARRANTIES, EXPRESSED, -IMPLIED OR STATUTORY, AND IS STRICTLY LIMITED TO THE TERMS HEREOF. SELLER SPECIFICALLY DISCLAIMS ANY WARRANTY OF -MERCHANT ABILITY OR OF FITNESS FOR A PARTICULAR PURPOSE.

2 Description

The device is designed to sample the environment at the installed location and alert the user to potentially dangerous levels of hydrocarbon gas. The device is shipped factory calibrated and is labeled with target gas, calibration gas and span setting information.

The output of the device is a standard 4 to 20 mA with HART. The 4-20 mA signal communicates the primary measured value using the 4-20 mA current loop. Additional device information is communicated using a digital signal that is superimposed on the analog signal. The device is compliant with HART Communications Foundation (HCF) Revision 7.0 format. Commercially available hand-held communicator devices or PC applications can be used to communicate with the device using the Device Description (DD) file that is available from the HART Communications Foundation website (www.hartcomm.org).

2.1 User Interface

This device does not provide a visual display of information. The gas level and basic device status are available via the 4-20 mA output signal. Other detailed device status is available via the HART signal. Details about this interface can be found in the PrimaX IR HART Specification located on the product CD shipped with the device.

The optional calibration cap provides an LCD display for easy and intuitive calibration of the device. The proper usage of this calibration cap is described in chapter [4.2 PrimaX IR Calibration](#).

The device should be installed where gas leaks are anticipated. The installation position depends on the gas density, either in the upper area of the room beneath the ceiling for gases lighter than air, or close to the ground for gases heavier than air. Also consider how air movement may affect the ability of the device to detect gas. Testing for ventilation patterns may be helpful in establishing locations for the device in enclosed areas.



Before beginning the installation, check that the delivered components are complete and correct, referring to the shipping documents and the label on the shipment carton.

2.2 Package Contents

The device will be delivered with the following items in the shipping carton:

- PrimaX IR sensor (316 Stainless Steel)
- Environmental guard
- Quick Start Guide
- Product CD, including this instruction manual, HART specification and installation drawing

2 Description

Figure 1 Overview of PrimaX IR parts



- | | | | |
|---|-----------------------------------------|---|------------------------------------------|
| 1 | Environmental guard | 4 | Calibration cap (optional) |
| 2 | PrimaX IR sensor (316 stainless steel) | 5 | HART Calibration cap/Bump cap (optional) |
| 3 | Stainless steel junction box (optional) | 6 | Remote HART calibration kit (optional) |

Accessories to be used with this product may be packaged separately. Check the enclosed shipping papers to identify all PrimaX IR accessories that have been ordered.

Accessories available for the PrimaX IR Gas Monitor include:

- Optional junction box equipped with a terminal strip for easy wiring
- Optional calibration cap for calibration operations
- Optional tether strap for environmental guard
- Optional HART Calibration cover/Bump cap
- Optional Remote HART Calibration kit

The complete list of accessories is provided in chapter 7 .

The device will be labeled with the information shown below:

- Target gas, calibration gas and span value
- Serial number and date of manufacture
- Area classification markings

3 Installation

3 Installation

3.1 Mechanical Installation

The device's dimensions are shown below in inches (mm):

Figure 2 Sensor with Aluminum Junction Box

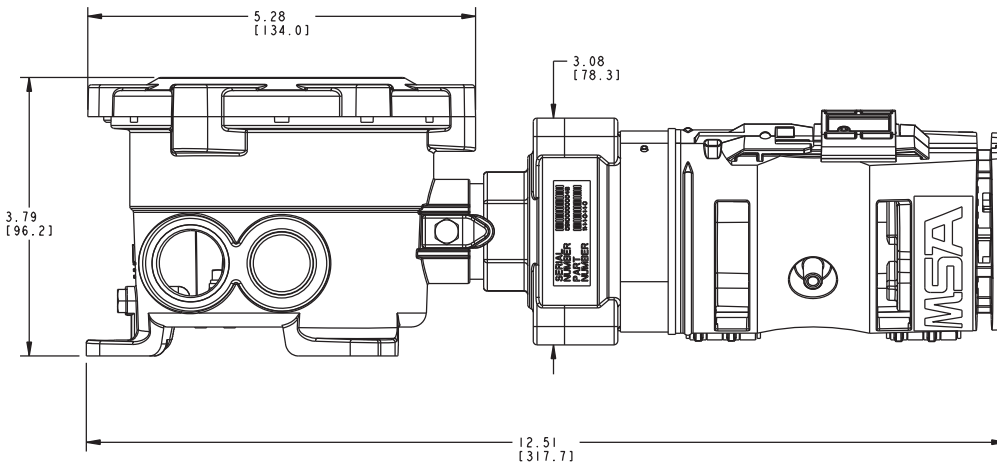
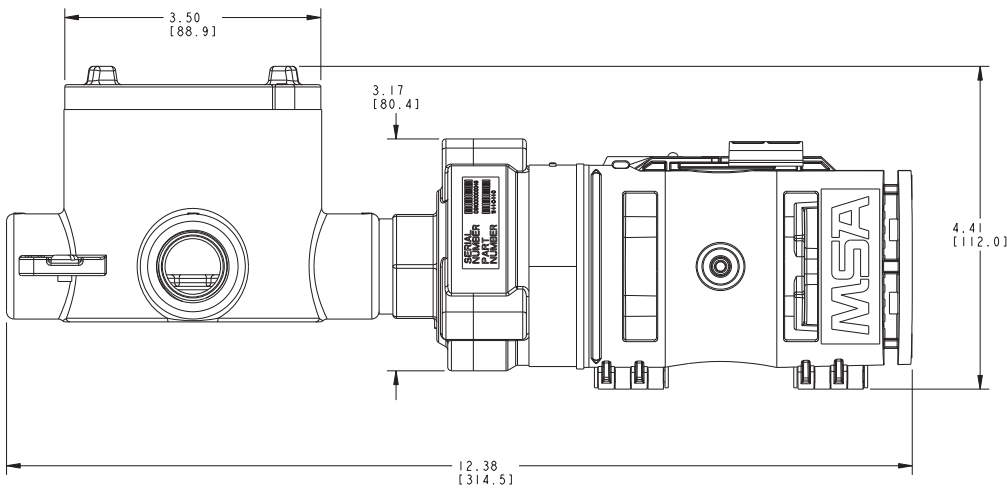

Figure 3 Sensor with Stainless Steel Junction Box



If a junction box is not being used, mount the device on a support by using suitable hardware (not supplied), and in accordance with local regulatory requirements.



MSA recommends mounting the sensor horizontally. Horizontal mounting will help prevent the build-up of particulate or liquid matter on the monitor's optical surfaces.

To ensure specified response time mount the sensor with the legs horizontal relative to each other as shown in [Figure 4](#)

Figure 4 Recommended mounting orientation

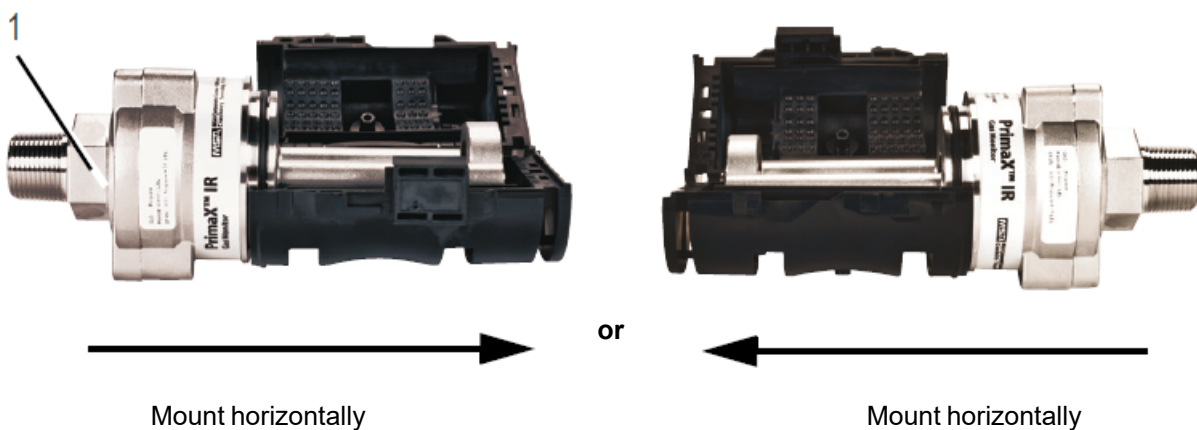

Hex nut size:

- 1 36mm - Metric
1-7/16 - Standard

WARNING!

Do not paint the device. If painting is done in an area where a sensor is located, exercise caution to ensure paint is not deposited on the sensor. Such paint deposits could interfere with the device operation. Solvents in the paint may also cause an alarm condition to occur.

Failure to follow this warning can result in serious personal injury or death.

WARNING!

Protect the device from extreme vibration. Do not mount the sensing head in direct sunlight, since this may cause the sensor to overheat. A stainless steel sunshield is available for the device to protect it from extreme environments.

Failure to follow this warning can result in serious personal injury or death.

CAUTION!

During sensor installation or removal, do not use any tools or apply excessive force to the two legs that support the unit's reflectors. Applying force to the legs can permanently damage the monitor.

Failure to follow this caution can result in minor or moderate injury.

MSA recommends that the device's environmental guard should be installed on the unit at all times. If the device is to be operated without the guard, frequent checks must be made to ensure particulate or liquid matter has not collected on the windows.

1. Use a wrench on the hex nut in the sensor neck to install or remove the sensor.

Do not apply torque to the two sensor legs.

Optional Junction Box Instructions:

If installing the device on a junction box, verify that the junction box area classification is appropriate for the installation environment. Two options are available for MSA junction boxes:

- Powder-coated Aluminum
- 316 Stainless Steel

A stainless steel mounting plate is included with either junction box to ensure that there is sufficient clearance from the installed surface (see [Figure 5](#) and [Figure 6](#)).

1. Install the mounting bracket and junction box using the bracket holes as the drilling template.

3 Installation

Figure 5 Mounting bracket for Aluminum Junction Box

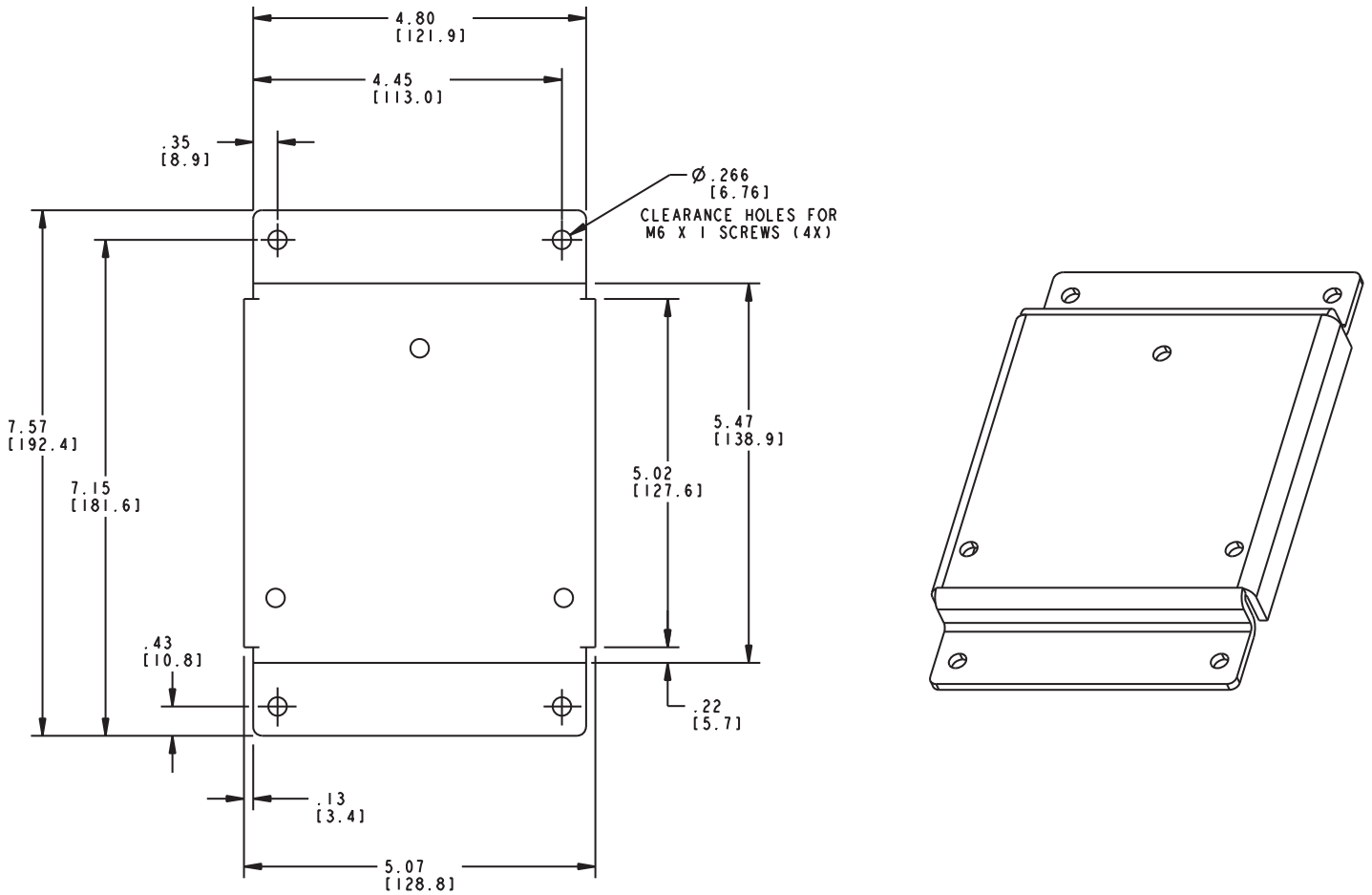
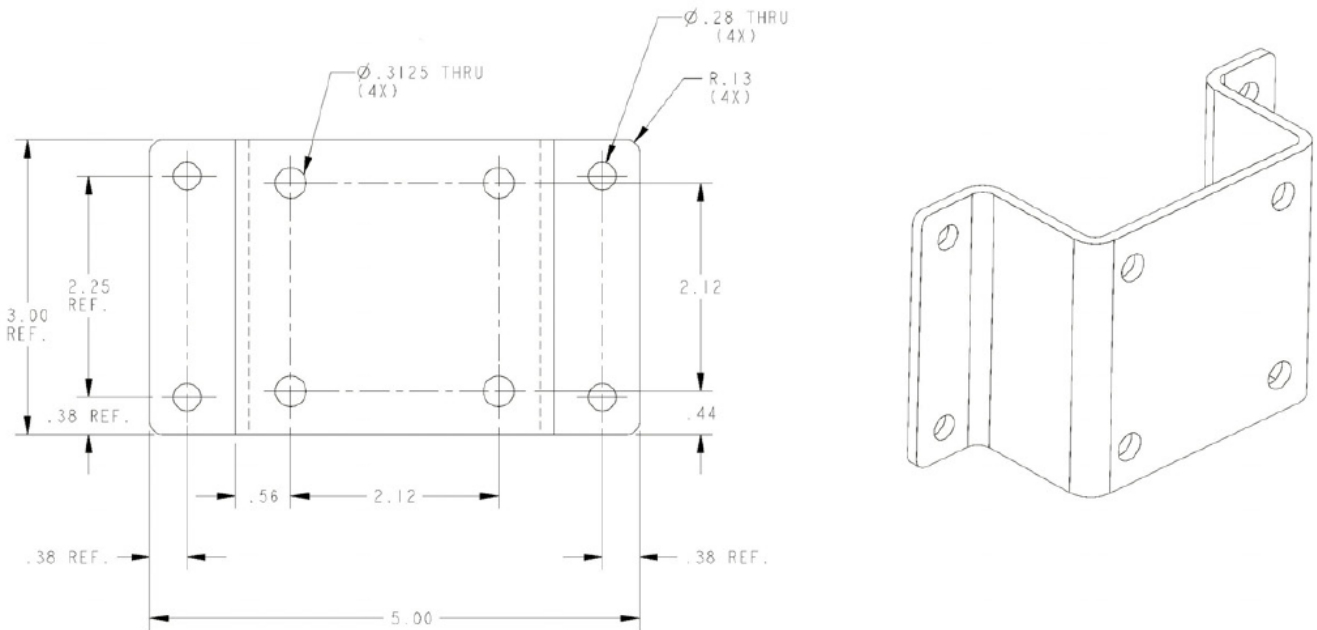

Figure 6 Mounting bracket for Stainless Steel Junction Box



2. If not using an MSA supplied junction box, refer to [Figure 2](#) or the dimensional drawing to ensure that there is adequate clearance. Ensure that the environmental guard can be easily removed and re-installed.
3. The optimum orientation for the device is horizontal.

3.2 Electrical installation

Instructions for Electrical Connection

CAUTION!

The device must be installed only in compliance with the applicable regulations, otherwise the safe operation of the device is not guaranteed.

Failure to follow this caution can result in minor or moderate injury.

- Shielded cable for measuring devices is recommended.
- Always observe maximum cable lengths and cross-sections shown below.
- Water or impurities can penetrate the device through the cable. In hazardous areas, it is recommended to install the cable in a loop just before entry into the device or to slightly bend it to prevent water from entering.

Wiring Requirements

The device is a three-wire transmitter that operates in the current source mode and can be wired directly to the input wires or with an optional junction box. The following table provides typical cable lengths and wire sizes for installation. The HART signal requires a load across the signal.

Wire Size vs Distance			
Power Supply Voltage	1.0 mm² (18 AWG)	1.5 mm² (14 AWG)	Signal Load (including termination)
24 Volts	480 m (1575 ft)	720 m (2362 ft)	With HART 250 ≤ load ≤ 500 Ω Without HART load ≤ 500 Ω

Proper installation should prevent water and dirt from entering the unit via the wires or conduit.

The device is provided with 4 wires for use. The table below shows the wire color definitions:

Wiring Color Definitions

Wire color	Definition
Red	24 VDC (DC +)
Yellow	4-20 mA Source (SIG)
White	0 VDC (DC -)
Green	Earth Ground

Use a maximum (Line + Load) resistance of 500 Ohm between the DC- (white) and 4-20 mA source (yellow) wires.

An external power source is required. Use a high quality, DC power supply with low noise characteristics. See the diagram below for power supply and wiring details:

Figure 7 Sensor Wiring Diagram

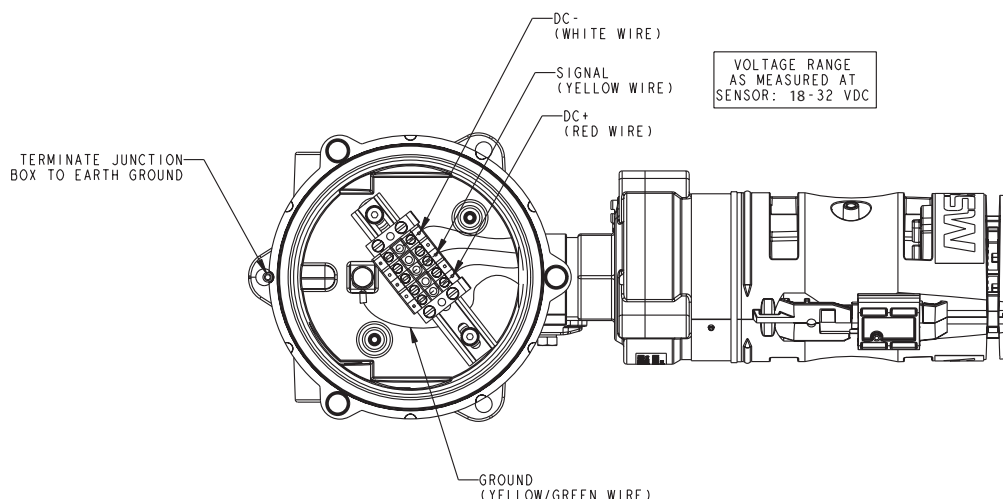

3 Installation

CAUTION!

Before wiring the device, disconnect or isolate all power connected to the device; otherwise electric shock could occur.

Failure to follow this caution can result in minor or moderate injury.

Input voltage (at sensor)	Power requirements	
	Nominal	Maximum
18 V DC	220 mA	350 mA
24 V DC	175 mA	250 mA
32 V DC	130 mA	200 mA

External Controllers

The device can be connected to any device capable of accepting a 4 - 20 mA sourcing analog signal. For FM approved systems, the connecting device must have latching alarms with manual reset. Ensure that your controller can read all signals. Check the MSA website www.MSAafety.com for available controllers.

The HART output is intended to be used with digital control systems that are compatible with HC Revision 7.0 protocol.

4 Start-up and Calibration

4.1 Initial Startup

The device is factory-calibrated and ready for use. The device provides a 4 - 20 mA output signal that can be used in conjunction with data acquisition controllers. The digital HART signal that is superimposed on the 4 - 20 mA output can be read by control systems that are in compliance with HART Revision 7.0 format.

During device operation, the 4 - 20 mA output signal is updated once/second and provides the information shown below:

4-20 mA Output Levels [Default Values]		
OPERATION	4 - 20 mA	Definition
SAFETY CRITICAL FAULT	0.0 mA	Sensor failure. Communications not -available to sensor
*FAULT	2.0 mA	Problem detected. Status available via HART interface
*OBSCURATION OR DIRTY OPTICS	2.5 mA	Light path is blocked
*POWER UP OR -SENSOR - CALIBRATION	3.0 mA	Unit power was recently applied or calibration in process with Cal Signal Enabled
*CLEANING MODE	3.5 mA	Defined in chapter 5 Maintenance
NORMAL	Gas value scaled from 4 - 20 mA for 0 - 100 % LEL	
OVERRANGE	20.0 - 20.5 mA	> 100 % LEL gas is detected by the device

*Output levels are customer configurable between 2.0 – 3.5 mA via the HART interface. See the Hart Specification on the product CD for more information.

Transient Fault conditions will be automatically cleared when the unit recovers from the fault condition.

MSA recommends verifying proper response to changes in mA outputs by using the "Enter Fixed Current Mode" command described in the PrimaX IR Link Help Guide to check the four fault conditions noted with a * above. These checks should be done at every calibration phase.

Calibrations

General

The calibration must be done at regular intervals in accordance with applicable national and regional regulations.

The device is calibrated at the factory. Nevertheless, it is recommended to recalibrate the device after installation. New sensors should be calibrated more often until the calibration records prove sensor stability. The calibration frequency can then be reduced to the schedule set by the safety officer or plant manager.

Signal

The 4 - 20 analogue signal is available within 1 minute of power-on but the device should be powered for at least 60 minutes before attempting calibration to allow for temperature stabilization.

CAUTION!

Carry out the calibration during commissioning as well as at regular intervals. This ensures optimum operation of the sensor.



It is recommended that all calibration components are connected before starting a calibration as it is necessary to apply test gas at the appropriate time as shown in [Figure 15](#).

Although the device is factory-calibrated, it is good practice to calibrate the unit once it is installed in its final environmental destination.

4 Start-up and Calibration

As with any type of gas monitor, the only true check of its performance is to apply gas directly to the sensor. New sensors should be calibrated more often until the calibration records prove sensor stability. The calibration frequency can then be reduced to the schedule set by the safety officer or plant manager.

Span gas selections are shown in chapter [4.3 Calibration Kits](#).

1. Read all calibration instructions before attempting an actual calibration.
2. Identify and become familiar with all of the calibration components.

Prior connection of the calibration components will make it easier to calibrate the unit.

⚠ CAUTION!

Failure to follow the above can result in inaccurate calibration.

Failure to follow this caution can result in minor or moderate injury.

4.2 PrimaX IR Calibration

The device can be calibrated using either the optional calibration cap locally at the sensor, or using the HART digital interface.



MSA recommends using a calibration gas value in the middle of the measuring range for optimum calibration.

Calibration methods

⚠ CAUTION!

The standard environmental guard is designed to offer fast response time and should not be used for bump or calibration without the Remote Calibration Inserts (see chapter [7.5 Insect Guard/Remote Calibration Inserts](#), P/N 10116419).

Failure to do so could dilute the sample and result in inaccurate calibration.

Although both a full calibration (zero and span) and zero only calibration can be performed on the device, a zero only calibration may be sufficient to properly calibrate the monitor. Normally, any degradation of the sensor's performance is associated with slight drifts in zero that, in turn, will adversely affect its span performance. After completing the zero calibration, perform a span check to ensure proper operation. For a span check, apply a gas of known concentration and verify that the measured response is within acceptable limits. If the span check is unsuccessful, perform a full zero and span calibration.

Figure 8 MSA Calibration Cap



Figure 9 Remote HART Hand-held



Figure 10 HART Calibration Cover/Bump Cap



Alternate Span Gas Settings

To achieve the most accurate calibration it is always best to use the gas of interest and calibrate at the operating temperature. If the target span gas is not available, an alternative span gas can be used with the values shown in the table below. The sensor label will identify the span gas and value used by the factory for calibration. Use of a reference gas for calibration may decrease accuracy.

The user may change the gas monitor's span value, gas name and gas curve through use of the PrimaX IR Link software found on the product CD. Please refer to the PrimaX IR HART Specification and the PrimaX IR Link Help Guide on the product CD.

Calibration Settings

Target Gas	100% LEL ¹	Performance Approved Range	Measuring Range	Calibration Gas	Span Value ²	t50	t90	Gas Cal Curve No.
Methane	4.40%	0-100%	0-100%	2.5% v/v Methane	57%	≤ 7 s	≤ 15 s	1
Methane	5.00%	0-100%	0-100%	2.5% v/v Methane	50%	≤ 7 s	≤ 15 s	1
Propane	1.70%	0-100%	0-100%	0.6% v/v Propane	35%	≤ 7 s	≤ 15 s	2
Propane	2.10%	0-100%	0-100%	0.6% v/v Propane	29%	≤ 7 s	≤ 15 s	2
Toluene	1.00%	0-30%	0-100%	2.5% v/v Methane	57%	≤ 11 s	≤ 28 s	3

4 Start-up and Calibration

Target Gas	100% LEL ¹	Performance Approved Range	Measuring Range	Calibration Gas	Span Value ²	t50	t90	Gas Cal Curve No.
Toluene	1.10%	0-30%	0-100%	2.5% v/v Methane	52%	≤ 11 s	≤ 28 s	3
n-Butane	1.40%	0-30%	0-100%	0.6% v/v Propane	37%	≤ 10 s	≤ 24 s	2
n-Butane	1.50%	0-30%	0-100%	0.6% v/v Propane	35%	≤ 10 s	≤ 24 s	2
Acetone	2.50%	0-100%	0-100%	2.5% v/v Methane	44%	≤ 11 s	≤ 25 s	2
Propylene	2.00%	0-50%	0-100%	1.0%v/v Propylene	50%	≤ 11 s	≤ 25 s	3
Propylene Oxide	1.90%	0-100%	0-100%	2.5% v/v Methane	19%	≤ 11 s	≤ 25 s	3
Propylene Oxide	2.30%	0-100%	0-100%	2.5% v/v Methane	16%	≤ 11 s	≤ 25 s	3
Ethane	2.40%	0-50%	0-100%	1.2%v/v Ethane	50%	≤ 11 s	≤ 23 s	3
Ethylene	2.30%	0-100%	0-100%	1.35% v/v Ethylene	59%	≤ 10 s	≤ 23 s	3
Ethylene	2.70%	0-100%	0-100%	1.35% v/v Ethylene	57%	≤ 10 s	≤ 23 s	3
Cyclopentane	1.40%	0-100%	0-100%	0.6% v/v Propane	35%	≤ 10 s	≤ 25 s	2
Cyclopentane	1.50%	0-100%	0-100%	0.6% v/v Propane	33%	≤ 10 s	≤ 25 s	2
Isobutane	1.30%	0-70%	0-100%	0.65%v/v IsoButane	50%	≤ 12 s	≤ 26 s	2
Isobutane	1.80%	0-70%	0-100%	0.6% v/v Propane	39%	≤ 12 s	≤ 26 s	2
Ethyl Acetate	2.00%	0-100%	0-100%	2.5% v/v Methane	21%	≤ 12 s	≤ 25 s	2
n-Hexane	1.00%	0-10%	0-100%	0.5%v/v n-Hexane	50%	≤ 11 s	≤ 24 s	2
n-Pentane	1.10%	0-30%	0-100%	0.55%v/v n-Pentane	50%	≤ 11 s	≤ 24 s	2

¹ IEC/UL/EN 80079-20-1 was used as bases for converting test and calibration gas concentrations from % LEL to % volume fraction

² For the measurement of n-Pentane, n-Hexane, Propylene, Ethane or Isobutane PrimaX IR shall be calibrated with the target gas at a span value of approximately 50% LEL.

Bump Check Procedure

A bump check verifies the sensor response to a known concentration of gas. The recommended equipment for a Bump Check is the HART Calibration Cover/Bump Cap (P/N 10122228). A known concentration of gas should be supplied to the inlet port of the Bump cap and compared to the gas value on the output signal (see [Figure 10](#)). Alternately, if using the environmental guard to perform a bump check the gas should be delivered to both ports of the environmental guard from a 1.5 l/min regulator. Use PrimaX IR Calibration Kit for the tubing, regulator and Remote HART screens shown below.

Figure 11 Bump Check setup with environmental guard



Calibration Cap Procedure

1. Remove the environmental guard from the device.
2. The calibration cap is equipped with a slot for an optional tether retention system. The figure below shows the location of the tether slot.

Figure 12 Calibration cap

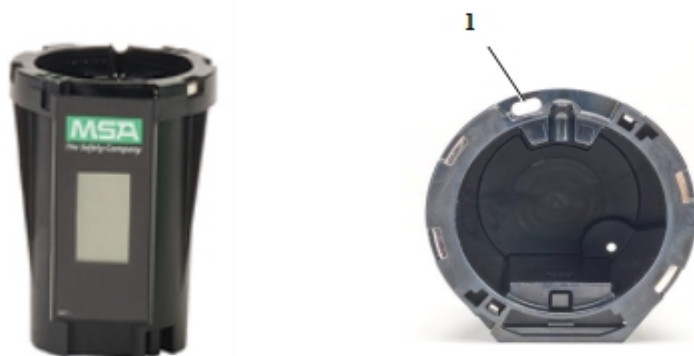

1 Tether slot

3. If the user can confirm that the ambient air is free of combustible gas, ambient air can be used in place of the zero gas cylinder. See [Figure 15](#) for a visual representation of the calibration process.
4. Install the calibration cap. Press firmly to ensure cap is properly seated.

The calibration process will start automatically when the cap is fully seated on the sensor housing.

Under normal conditions, the display will show all icons steady at power-up.

5. The calibration cap display indicates the zero gas cylinder symbol and flashes, indicating that the device is in Zero Calibration mode.

The initial 30 seconds is intended to give the user time to apply gas to the sensor. During this time, the user can abort the process by removing the calibration cap.

After the initial 30 seconds, the device will start the Zero calibration adjustment. The Zero Calibration is indicated by the white cylinder (see [Figure 12](#)) and the word "Zero".

Removal of the calibration cap after the initial 30 seconds will result in a calibration fault. This will abort the present calibration and the device will continue to operate with the previous calibration settings.

6. Apply zero gas to the calibration port at an approximate flow rate of 1.5 LPM while the cylinder symbol is flashing. Zero gas can be supplied as ambient air or from the zero gas cylinder in the calibration kit as noted in [chapter 4.3 Calibration Kits](#).

Figure 13 Zero Gas Cylinder Symbol



7. When the Zero calibration is successful, the checkmark symbol “✓” will appear. If only performing a Zero calibration, remove the calibration cap. Following a successful zero, the span process will automatically begin within 30 seconds following the zero “✓”.

8. If the Zero calibration fails, the display will show an X for approximately 2 minutes, and will then power down.

If the Zero calibration fails, remove the calibration cap and reinstall to start another zero attempt. If multiple failures occur, contact an authorized MSA service center.

9. When the display flashes the span gas symbol, apply the span gas through the calibration cap port (see Fig. [Figure 8](#)).

The unit must see gas within 30 seconds after the span symbol starts to flash or a calibration fault may occur. The initial 30 seconds are intended to give the user time to apply gas to the sensor. During this time, the user can abort the Span process by removing the calibration cap.

The display will then flash at a faster rate to indicate active calibration by the sensor.

Figure 14 Span Gas Cylinder Symbol



10. When the Span calibration is successful, the checkmark symbol “✓” will appear. If the Span calibration fails, an X will be displayed for approximately 2 minutes, and the device will then power down.

See [chapter 5 Maintenance](#) for subsequent action upon calibration failure.

11. When calibration is complete, stop the gas flow and remove the calibration cap. Reconnect the environmental guard or flow cap to the sensor. The calibration cap will automatically power down once removed from the sensor. The 4-20 mA is held at the sensor calibration level for two minutes to reduce the chance of a nuisance alarm upon completion of a calibration procedure.

During calibration and this 2 minute period, the unit will not be detecting any gas in the ambient area.

12. Alternately, the device can be commanded via HART to track the gas level during calibration (see the Calibration Signal Enable/Disable command in the HART Specification).

Once the calibration cap is removed it can take up to two minutes for gas to diffuse and the device to read normal ambient levels.

Steps 5-11 are shown in the figure below:

Figure 15 Calibration Cap Sequence of Events

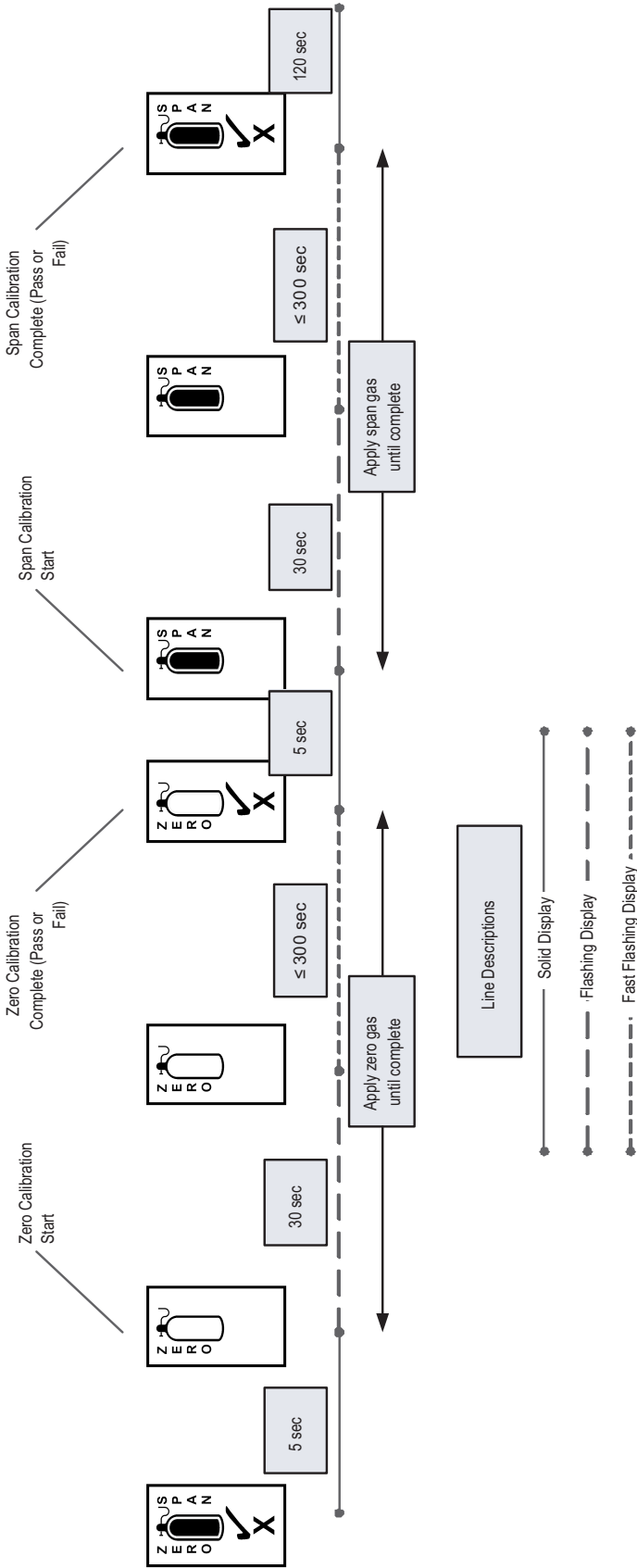

4 Start-up and Calibration

When a Zero or Span calibration failure occurs, the device reverts back to its previous successful calibration settings.

If the calibration cap is left on for more than 15 minutes after calibration concludes, the 4 to 20 mA signal indicates Fault status.

⚠ WARNING!

The calibration cap must be removed from the device after completing the Zeroing and/or Spanning procedure; otherwise, the sensor cannot perform properly.

Failure to follow this warning can result in serious personal injury or death.

When the calibration cap battery is nearing the end of its useful life, the LCD will display all the icons in a series of rapid flashes at power-up before it starts the normal calibration cycle. The battery is non-serviceable and the calibration cap would need to be replaced once the battery is depleted.

HART Calibration Procedure

The device can be calibrated using a HART compatible communications interface with Device Description capability (DD), such as the Emerson 375 or 475 Field Communicator (see [Figure 8](#)). Ensure that the HART hand-held communicator is compatible with the area classification. This hand-held HART communicator must be HART revision 7.0 compliant and can be obtained from a HART authorised supplier. See the PrimaX IR HART specification found on the product CD for the calibration command definitions or visit the MSA website at www.MSAafety.com.

Calibration can also be performed via the HART interface with optional screen inserts in the Environmental Guard. As shown in [Figure 16](#), the environmental guard can be fitted with these screens that will allow the calibration gas to be retained in the enclosure long enough for a valid zero and/or span reading to be obtained under still-air conditions of less than 1 m/s.

⚠ CAUTION!

Use of these inserts will increase the sensor response time to ambient gas conditions up to 210 seconds. Ensure that the operational conditions are appropriate for use of these screens.

Failure to follow this caution can result in minor or moderate injury.

When supplying tubing to the environmental guard to allow remote HART calibration, gas should be delivered to both ports of the environmental guard from a 1.5 l/min regulator as shown in [figure Figure 16](#):

Figure 16 HART calibration set-up



1 Screens

When used under windy conditions >1 m/s, a calibration cover must be used instead of the environmental guard while applying the zero and span gas. Gas should be applied at 1.5 l/min. See [Figure 16](#) for a picture of the calibration cover.

Figure 17 HART Calibration Cover



WARNING!

Ensure that the calibration cover is removed after calibration is complete. This cover is intended to block the flow of ambient air into the sensor during calibration, and in normal operation must ALWAYS be removed.

Failure to follow this warning can result in serious personal injury or death.

For applications where access to the HART signal is needed in hazardous areas, MSA provides the HART Module as shown in [Figure 18](#)

Figure 18 HART module



The explosion-proof port allows access via a HART hand-held controller using the cable shown above (P/N 10081441).

4.3 Calibration Kits

Calibration kits are available for the device. The recommended calibration kits are shown in the following table.

GAS TYPE	CAL CYLINDER	CYLINDER P/N	CAL KIT #
Methane	2.5% Methane	10028032	40
Propane	0.6% Propane	10028034	40
Zero Gas	100% Nitrogen	10028030	40

See the PrimaX IR section of www.MSAafety.com for additional PrimaX IR calibration gases.

5 Maintenance

5.1 General

WARNING!

Before working on the device, turn off the power and secure against restart.

Failure to follow this warning can result in serious personal injury or death.

There are NO field repairable internal components for this device. Do not attempt to open the enclosure of the device, it is factory sealed for protection from hazardous environments. If the troubleshooting guides in chapters [5.2 Troubleshooting](#) and [5.3 HART Information for Troubleshooting](#) do not alleviate the problem, contact your MSA representative.

5.2 Troubleshooting

The 4-20 mA output provides a limited set of information for diagnostic purposes. Additional troubleshooting steps are outlined below.

General Troubleshooting Guide

Indication	Action
Sensor IR source does not flash	Verify sensor and facility wiring according to the installation section and then reapply power
Sensor IR source is flashing but no 4-20mA signal.	Verify sensor and facility wiring according to the installation section and then reapply power.
FAULT mA output	Check power supply and restart. Check to ensure that the calibration cap was not left on the sensor for an extended time. If an Underrange error is indicated via the HART interface, perform a zero calibration.
OBSCURATION mA output	Verify optical path is not obscured or perform the cleaning procedure below.
Elevated gas reading when no gas is expected to be present	Clean the optical window and mirror using the cleaning procedure below. Apply zero gas to see if reading drops to zero. If it does not, then perform Zero and Span calibration.
Unstable 4 mA signal after power on and warm up	Verify DC voltage supply is between 18 - 32 VDC. Total voltage, including any AC components, must be less than 32 VDC. If power supply is within 18 - 32 VDC, check for noise on the input power line. Use of an external filter may be required in this case.
mA output current does not change when gas is applied	Verify that gas flow path is unobstructed. Visually inspect the gas inlets and the regulator. Verify that you are not in calibration mode or any of the defined mA output levels shown in chapter 4.1 Initial Startup . Verify that the device is not in Fixed Current Mode (Commanded via HART).
Calibration cap span fails.	Pull the cap off and evacuate gas from the calibration cap. Retry the calibration procedure and verify the Zero calibration was successful. If Zero calibration returns "✓" and the Span calibration fails, verify adequate span gas and flow. Verify that the Span gas is applied within the 30 second window. Check the o-ring integrity to ensure a good seal between the sensor and the calibration cap. Check the cap for damage.

General Troubleshooting Guide

Indication	Action
Calibration cap rapidly flashes all icons during startup	The calibration cap battery is nearing the end of its useful life. The calibration cap will continue to operate until the battery is consumed.
Known gas concentration response is incorrect	<p>Calibrate. If calibration fails, remove power and reapply.</p> <p>Verify span gas flow rate and cylinder accuracy. Verify environmental guard and/or flow cap are not obstructed.</p> <p>Verify line load is according to electrical installation chapter 3.2 Electrical installation. Verify ambient temperature range is appropriate for the device rating.</p>
One source not flashing	<p>The PrimaX IR is designed to meet all specifications with only one source. Source status is available through HART communication. See HART manual for details.</p> <p>Perform standard calibration.</p> <p>No further action required.</p>

5.3 HART Information for Troubleshooting

The HART digital signal can provide additional information on the unit's health and status. Some of the information includes specific fault, calibration and obscuration status.

All available status bytes are defined in the PrimaX IR HART Specification found on the product CD. Refer to this document for complete HART command and status definitions. Use the HART digital interface to query the unit to provide additional troubleshooting information.

5.4 Cleaning

The presence of particulate matter, oil films, liquid water, or the residue from water drops on the device optics can adversely affect its performance. The environmental guard is designed to prevent solids or liquids from reaching the monitor's optical system. Heating elements are also incorporated into the unit to prevent water condensation. Under severe conditions, however, some material may collect on these surfaces and it may be necessary to occasionally check and clean the windows. These steps should be followed if the sensor is exposed to water and the sensor goes into beam blocked fault, see the fault table for more information.

1. Remove the environmental or flow cap.

Figure 19 Remove Environmental Guard



2. Place an opaque object (piece of paper, two fingers, etc.) between the light source window and the mirror to completely obscure the light path for two to three seconds (see [Figure 20](#)).

If the opaque object is left in the light path for longer than 10 seconds, an Obscuration fault will be set on the mA output (see chapter [4.1 Initial Startup](#)).

The device enters the Cleaning Mode for 5 minutes.

Figure 20 Light path obscuration



WARNING!

The sensor will not respond to the presence of gas in cleaning mode.

Ensure that the environment is free of combustible gases before starting the cleaning procedure.

Failure to follow this warning can result in serious personal injury or death.

- The analog current output will be set to the Cleaning Mode value (see chapter [4.1 Initial Startup](#)) during this time.
- If monitoring the HART signal, the Cleaning Status bit will be set.

Although both windows are made of a highly durable material that is not easily scratched, avoid excessive pressure when cleaning them. Clean, cotton tipped applicators are recommended to remove material collected on the windows.

3. Use a dry applicator or one moistened with distilled water to wipe the window and remove dust.
4. Use an additional clean, dry applicator to remove any residual water.
5. Use an applicator moistened with isopropyl alcohol to remove heavy deposits of solids, liquids or oil films. Clean the window again with a second applicator moistened with distilled water; then, dry the window with a final applicator.
6. Avoid using excessive amounts of water or alcohol in the cleaning procedure, and inspect the window to ensure that the entire surface is clean.



When the cleaning process is complete, be sure to remove all objects from the light path.

When exiting the Cleaning Mode, the unit returns to normal operation. Note that residual cleaning fluids may result in an elevated signal until completely dry.

7. Inspect the environmental guard for any blockages, then replace the environmental guard on sensor.

After cleaning the windows, it is advisable to check the sensor's response to both zero and calibration gas.

CAUTION!

Do not place foreign objects in the sensor's analytical region (except per the Cleaning Procedure above); otherwise, the infrared beam can be partially blocked, causing the sensor to generate false readings. All objects must be removed from the sensor's analytical region for it to function properly.

Failure to follow this caution can result in minor or moderate injury.

CAUTION!

If water or isopropyl alcohol is used to clean the sensor's windows, any residue from the cleaning procedure must be completely dissipated before returning the unit to service. Checking the sensor's response to zero gas is the best way to purge residual cleaning materials from the sensor. Ensure that the sensor's reading is stable before zeroing or calibrating the sensor (see chapter [4 Start-up and Calibration](#)).

Failure to follow this caution can result in minor or moderate injury.

5.5 Environmental Guard Cleaning

It is good maintenance practice to occasionally clean the environmental guard by removing it and rinsing it with water, or using compressed air to clean it (see [Figure 21](#)). Always reinstall the environmental guard for normal operations to provide protection against damage to the mirror and windows, and to help prevent dust from accumulating on the optical surfaces.

Figure 21 Environmental Guard Cleaning



5.6 Calibration Cap Cleaning Procedure

In general, the calibration cap should not require any maintenance. However, if it is used in extremely dirty or solvent based environments, it may be necessary to clean the light sensor if the calibration cap performance is not adequate.

1. Use a clean, dry applicator and isopropyl alcohol to gently swab the light sensor, as shown in [Figure 22](#) .

⚠ CAUTION!

Never immerse the calibration cap in water or damage will occur.

Failure to follow this caution can result in minor or moderate injury.

Figure 22 Calibration cap diode cleaning



6 Technical Data

MEASURING RANGE*		0-100 % LEL
OPERATING -TEMPERATURE RANGE	Sensor	-50 to +80 °C (-58 to +176 °F)
Calibration Cap	-30 to +60 °C (-22 to +140 °F)	
STORAGE -TEMPERATURE RANGE	Sensor	-40 to +80 °C (-40 to +176 °F)
DRIFT	Zero Drift	< 1 % LEL/ 3 months
	Span Drift	<2 % LEL/ 3 months
NOISE		< 1 % FS
STEP CHANGE -RESPONSE**	t50 with Environmental Guard	≤ 7 sec
	t90 with Environmental Guard	≤ 15 sec Methane ≤ 15 sec Propane
HUMIDITY		15 to 95 % RH, non-condensing
PRESSURE		600 - 900 mmHg (80 - 120 kPa)
SENSOR LIFE	see chapter 1.4 MSA Permanent Instrument Warranty	
IN-RUSH CURRENT		< 350 mA
POWER INPUT		18-32 VDC including any AC components
POWER CONSUMPTION		< 6.0 W
SIGNAL OUTPUT	4-20 mA	3-wire current source
PHYSICAL -CHARACTERISTICS	LENGTH	203 mm
	WEIGHT	1.5 kg
	MATERIAL TYPE	316 Stainless Steel
INGRESS PROTECTION		NEMA 4X IP66/67

*Note: Gas detection performance %LEL range may differ from 0-100%LEL, see section [4.2 PrimaX IR Calibration](#) for additional information.

** Note: Additional response times for gas/vapors not listed are included in section [4.2 PrimaX IR Calibration](#).

Deadband Suppression: From the factory the PrimaX IR sensor includes a deadband that suppresses indications between 0%LEL and 1%LEL. To disable this feature please contact MSA for details.

7 Accessories

The following accessories are available for the device:

Description	Part Number	
Calibration cap	10111874	Figure 1
Aluminum junction box kit (Includes mounting bracket)	10117607 – NPT 10117606 – M25	Chapter 3.1 Mechanical Installation
316 stainless steel junction box kit (Includes mounting bracket)	10117608 – NPT 10117609 – M25	Figure 1
Insect screen/Remote calibration inserts*	10116419	Chapter 7.5 Insect Guard/Remote Calibration Inserts
Sun shield*	10113481	Chapter 7.2 Sunshield
HART calibration cover / Bump Cap	10122228	Figure 8
HART hand-held communicator cable	10081441	Figure 9
Remote HART Calibration Kit*	10122783	Figure 16 , Figure 28
1.5 LPM Flow Regulator	478358	
Flow cap*	10113100	Chapter 7.1 Flow Cap
3-way pushbutton valve	635729	Chapter 7.1 Flow Cap
Sensor O-ring	10105967	
Environmental guard	10113663	Figure 1
Stainless steel tether	10114097	Figure 12
Duct mount kit*	10114373	Chapter 7.3 Duct Mount Kit
HART Junction Box (-40°C to +60°C) (See Intrinsically Safe Control Drawing SK3098-1585)	10246267 - M25 10246266 - NPT	Chapter 7.4 HART Module

* Note: Accessories noted not included in cFMus gas detection performance approval.

7.1 Flow Cap

Figure 23 Flow cap



The flow cap is for use with a sampling system. It is available in 316 stainless steel and is secured to the sensor in place of the environmental guard with two screws.

A 3-way pushbutton valve is available for ease of calibration when using the flow cap. The sample flow and the calibration gas can both be plumbed to this valve, and the operator holds down the pushbutton to switch the flow to the calibration gas.

Use a gas flow rate of 1.5 l/min when using the flow cap to achieve the response times stated in [chapter 6 Technical Data](#).



Using the flow through adapter can extend the response time, depending on the gas flow rate and system design.

7.2 Sunshield

The sunshield is a 316 stainless steel plate that protects the sensor from direct sunlight and from excessive temperature rise.

Figure 24 Sun shield

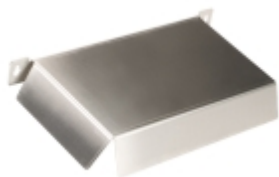

7.3 Duct Mount Kit

Gas monitoring in air ducts can be performed by means of this duct mount flange.

Install the sensor in a location that is convenient for maintenance, where it will be exposed to a representative sample and is not subject to extremes of flow, turbulence, temperature and particulate.

When installing, the direction of flow inside the duct must be as shown in [Figure 25](#).

Calibration of the device mounted in an air duct must be done with the HART interface. Once calibration has been initiated, apply the calibration gasses via the gas calibration port. Ensure that the duct is free of all gases to which the sensor will respond and the duct flow rate is below 1 m/s. If hydrocarbon combustible gas is present in the duct, the sensor must be removed from the duct during calibration. The sensor can be removed from the duct mount bracket via four screws.

Figure 25 Duct mount

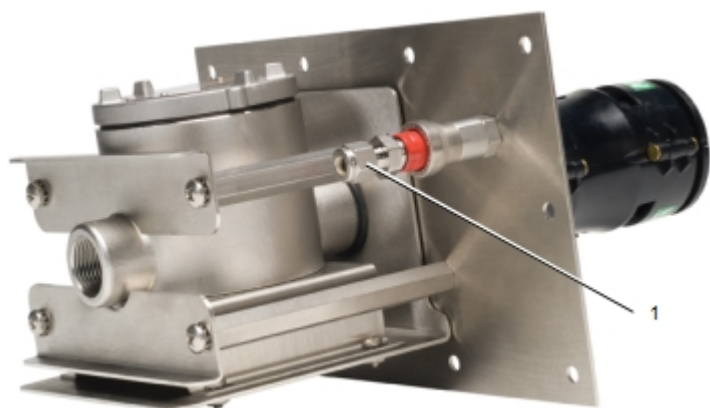

1 Gas calibration port

7.4 HART Module

The HART Module is a 316 Stainless Steel enclosure that provides a hazardous area approved HART port for access to the HART signal. The PrimaX IR can be mounted to this module using an available port and all applicable facility wiring rules from Section apply to wiring the HART Module.

Figure 26 HART module



An optional cable is available from MSA to connect to the XP HART port from a hand-held controller.

7.5 Insect Guard/Remote Calibration Inserts

For applications where HART is being used for calibration and the sensor is located in a remote location where use of the calibration cover is not practical, optional screen inserts are available. These inserts snap into the environmental guard (see [Figure 27](#)) and permit a very slow diffusion of gas through the tight mesh screens. This allows enough zero and span gas to be retained in the environmental guard for the calibration procedure to be accurate for still air applications.

⚠ CAUTION!

Use of these inserts will increase the sensor response time to ambient gas conditions up to 210 seconds. Ensure that the operational conditions are appropriate for use of these screens.

Failure to follow this caution can result in minor or moderate injury.

These screens can be used as an insect guard.

Figure 27 Remote cal/ Insect screen inserts



For remote calibrations the HART Remote Calibration Kit is also recommended (P/N 10122783). The components of this kit are shown below.

Figure 28 Remote HART Calibration kit



8 Approvals

8.1 PrimaX IR ATEX/IECEX Approval Information

Manufacturer:	MSA -The Safety Company 1000 Cranberry Woods Drive Cranberry Township, PA 16066 USA
Year of Manufacture:	see Label
Serial Nr.:	see Label
ATEX Approval Information	
Approvals Standards According to the Directive 2014/34/EU (ATEX) & UKSI 2016:1107 (UKCA)	Type of protection: EN IEC 60079-0:2018, EN 60079-1:2014 EN 60079-31:2014 Measuring function for explosion protection: EN 60079-29-1:2016, EN 50271:2015
ATEX / UKCA Marking	 II 2 G Ex db IIC T4 Gb II 2 D Ex tb IIIC T130°C Db IP66/67 -50°C ≤ Ta ≤ +80°C EN 60079-29-1 FM21ATEX0083X / FM22UKEX0134X
Quality Assurance Notification:	0080 EU / 2503 UKCA
EMC Conformance according to the Directive 2014/30/EU:	EN 61000-6-3:2021
IECEX Approval Information	
Approvals Standards	Type of protection: IEC 60079-0:2017, IEC 60079-1:2014, IEC 60079-31:2013 Measuring function for explosion protection: IEC 60079-29-1:2016
IECEX Marking	Ex db IIC T4 Gb Ex tb IIIC T130°C Db IP66/67 -50°C Ta +80°C IECEX FMG 21.0033X IEC 60079-29-1
ATEX/IECEX Performance Approved Gases	
Measuring Range: 0-100% LEL Performance Approved: 0-100% LEL	Methane, Propane, Propylene, Propylene Oxide, Acetone, Cyclopentane, Ethyl acetate, Ethylene
Measuring Range: 0-100% LEL Performance Approved: 0-70% LEL	Isobutane

8 Approvals

Measuring Range: 0-100% LEL Performance Approved: 0-50% LEL	Propylene, Ethane
Measuring Range: 0-100% LEL Performance Approved: 0-30% LEL	n-Butane, n-Pentane, Toluene
Measuring Range: 0-100% LEL Performance Approved: 0-10% LEL	n-Hexane

For additional approval information see www.MSAafety.com.

Special conditions for safe use:



- The gas monitor PrimaX IR is equipped with a tapered NPT thread or a metric thread for mounting to a connection enclosure of protection type increased safety “e” or protection type flameproof enclosure “d”.
- When mounting the gas monitor to an enclosure of protection type flameproof enclosure “d”, the reference pressure of the separate enclosure for the connection must not exceed 10.5 bar. The test of the mechanical strength of the separate enclosure for the connection and the test of the connecting thread with respect to explosion hazards must be ensured within the framework of the type test of the electrical apparatus, which is attached to the gas monitor PrimaX IR. The threaded hole to which the gas monitor is attached must meet the requirements of section 5.3 (Table 4/5) of IEC 60079-1.
- Due to the limitations on the potting used for the wire bushing on the PrimaX IR, the service temperature within the separate enclosure (the enclosure the PrimaX IR is mounted to) must not exceed 120°C.
- When mounting the gas monitor to enclosures in type of protection increased safety “e”, the mechanical resistance and the IP protection (IP6X) of the mounted enclosure has to be ensured by the type test of the electrical apparatus being mounted to the gas monitor. After mounting of the gas monitor onto an enclosure in type of protection increased safety “e”, the clearances and creepage distances must meet the requirements of Table 2 of IEC 60079-7. The non-shielded cables of the gas monitor must be routed and connected so as to be mechanically protected and corresponding to the temperature resistance of the cables as per 4.6.2, 4.8.2 and 4.9 of IEC 60079-7.
- For dust applications, any intensive electrostatic charging processes to the instrument label has to be prevented.
- The 3/4” NPT fixture has to be sealed with 2 layer PTFE sealing tape or according to the instructions of the manufacturer of the enclosure with NPT thread; when removed, new PTFE sealing has to be used after reinstalling.
- The gas monitor PrimaX IR must be screwed into the housing wall such that it is secured against self-loosening. The specified minimum thread depth of the add-on housing has to be observed.
- The gas monitor PrimaX IR must be included into the earthing and equipotential bonding of the complete system, including the enclosure it is connected to.
- The screw heads are filled with potting to prevent self-loosening and unauthorized entry. The user may not open the enclosure. Opening of the device will invalidate the type approval.

8.2 PrimaX IR cFMus Approval Information

Manufacturer:	MSA -The Safety Company 1000 Cranberry Woods Drive Cranberry Township, PA 16066 USA
---------------	-------------------------------------------------------------------------------------------

Year of Manufacture:	see Label
Serial Nr.:	see Label
cFMus Approval Information	
Approvals Standards	FM 6310, FM 6320 CSA C22.2 60079-29-1
cFMus Marking	Class I, Div 1, Groups A, B, C, D; T4 Class II, Div 1, Groups E, F, G -50°C ≤ Ta ≤ +75°C FM20US0151 FM20CA0074
cFMus Performance Approved Gases	
Measuring Range:	Methane, Propane
0-100% LEL	
Performance Approved:	
0-100% LEL	

8.3 Prima X IR Calibration Cap US/CAN/ATEX Marking

Manufacturer:	MSA -The Safety Company 1000 Cranberry Woods Drive Cranberry Township, PA 16066 USA
Product:	PrimaX IR Calibration Cap
Type of protection:	60079-0, 60079-11
ATEX Marking:	 II 2 G Ex ia IIC T4 -30°C ≤ Ta ≤ +60°C
EC-Type Examination -Certificate:	LCIE 10 ATEX 3090
IECEx Marking:	Ex ia IIC T4 -30°C ≤ Ta ≤ +60°C
IECEx-Type Examination Certificate:	IECEx LCI 10.0038 X
North American Marking:	 Intrinsically Safe for use in Class 1, Div. 1, Group A, B, C, D -30°C ≤ Ta ≤ +60°C Exia T4
Battery:	Panasonic BR 1632A
Quality Assurance Notification :	0080
Year of Manufacture:	see Label
Serial Nr.:	see Label
EMC Conformance according to the Directive 2014/30/EU :	EN 61000-6-3:2007

For additional approval information see www.MSAsafety.com

8 Approvals

8.4 Prima X IR Calibration Cap UKCA Marking

Manufacturer:	MSA -The Safety Company 1000 Cranberry Woods Drive Cranberry Township, PA 16066 USA
Product:	PrimaX IR Calibration Cap
Marking:	 Ex ia IIC T4 Gb -30°C ≤ Ta ≤ +60°C
UKCA Examination Certificate:	CML 21UKEX2419X
Battery:	Panasonic BR 1632A
Quality Assurance Notification :	2503
Year of Manufacture:	see Label
Serial Nr.:	see Label

8.5 Special conditions for the safe use according to ATEX and SIL applications

The PrimaX IR Gas Monitor has been subjected to rigorous reliability and functional safety assessments, which have culminated in the gas monitor being certified to IEC 61508, EN 50271 by TÜV Rheinland Industrie Service GmbH. The tables below list the SIL parameters for this device.

Safety relevant parameters for the PrimaX IR Gas Monitor:

Type	B
Structure	1oo1 or 1oo2
HFT	0 or 1
Safe Failure Fraction (SFF)	96 %
DC	92 %
λ_S (Detected safe failure rate)	1154.7fit
I_{DU} (Undetected dangerous failure rate)	104.1fit
I_D (Dangerous failure rate)	1154.7fit
I_{DD} (Detected dangerous failure rate)	1050.6fit
PFD, PFH	see table
MTTR	72 hr
TI (Test Interval)	see table
Ambient Temperature	40 °C

	PFD ₁₀₀₁	PFD ₁₀₀₁ %_SIL2	PFD ₁₀₀₂	PFD ₁₀₀₂ %_SIL3	PFH ₁₀₀₁	PFH ₁₀₀₁ %_SIL2	PFH ₁₀₀₂	PFH ₁₀₀₂ %_SIL3
16 weeks TI	5.1×10^{-5}	0.5%	2.3×10^{-6}	0.2%	2.1×10^{-8} 1/h	2.1%	1.1×10^{-9} 1/h	1.1%
52 weeks TI	1.1×10^{-4}	1.1%	5.5×10^{-6}	0.6%	2.1×10^{-8} 1/h	2.1%	1.1×10^{-9} 1/h	1.1%

Possible structures and acquirable SILs

The following table shows, which structure has to be selected, to fulfil the requirements of a special SIL.

LDM = Low Demand Mode

HDM = High Demand or Continuous Mode

	SIL1		SIL2		SIL3	
	LDM	HDM	LDM	HDM	LDM	HDM
Structure 1oo1	X	X	X	X		
Structure 1oo2	X	X	X	X	X	X

Depending on the selected configuration and the sensor version, the following safety-relevant parameters have to be considered while implementing the safety loop:

General Conditions for Safe Use

- The application advice and the limitations of the manual have to be considered. For calibration and maintenance, the regional and national regulations have to be considered.
- A defective device has to be repaired within 72 hours.
- The HART® interface cannot be used for the transmission of safety related data.
- The connected controller has to monitor the 4-20 mA signal current for values below 4 mA and above 20 mA.
- A functional check/calibration check has to be done for the complete system.
- A visual check has to be done together with the calibration.
- A system check has to be done every year.
- Calibration and adjustment are part of the function/calibration check.
- The test gas must be the gas to be monitored. The concentration of the test gas has to be in the middle of the measurement range.
- For zero gas, clean air, free of hydrocarbon combustible gas or synthetic air, has to be used.
- An adjustment has to be done under the following conditions:
 - difference at zero > +/- 5 % UEG (LEL)
 - difference at sensitivity > +/- 20 % of the rated value
- If the calibration is inside of the valid tolerance, the calibration interval can be doubled.
- The maximum of the calibration interval is 52 weeks.
- The gas monitor has to be replaced if the sensor sensitivity during the operation is reduced to less than 50 % of the initial sensitivity.
- For the power supply a SELV/PELV version or the requirements of EN60950 and EN50178 has to be fulfilled.

Special conditions for SIL 2

- The 4-20 mA output of the device must be monitored regarding deviations.

Special conditions for SIL 3

- The use of the sensors is allowed only in a 1oo2 - structure.
- The 4-20 mA output of the device must be monitored regarding deviations.